

Issue 3/2002

CONTENTS

In this edition of Movement & Positioning we present:

- **PICMA low-voltage piezo-ceramics**
- **Trade show dates 2003**
- **New PI website**
- **PIHera NanoPositioning systems with 0.5 mm travel: P-620**
- **Dynamic Linearization for scanning applications**
- **IntelliStep: C-161**
- **HEXALIGHT: M-840**
- **Piezoelectric actuators in mechanical engineering**
- **E-665.CR analog controller**
- **P-721.CL PIFOC microscope objective positioner and scanner with capacitive sensors**
- **M-110 translation stage**
- **S-334 tip/tilt mirror with +/- 25 mrad tip/tilt range**
- **2003 preview**

Send for further information and speak to us about your applications!

Another worldwide first

PIEZO ACTUATORS WITH CERAMIC INSULATION

The PICMA (PI Ceramic Monolithic Multilayer Actuator) is a new generation of piezoelectric actuators from PI Ceramic which, after many years of research and development, now make available the following advantages over the already outstanding characteristics of our previous actuators:

- Longer lifetime
- Higher dynamic load rating
- Higher operating temperature range
- Higher temperature stability
- Ceramic insulation, no outgassing of polymer insulation materials
- Certified vacuum compatibility
- Extremely well-suited for closed-loop operation

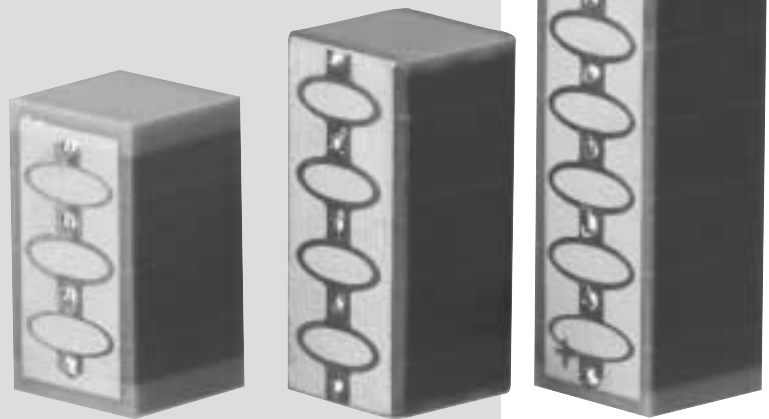

P-885
PICMA actuators

The new actuators are the first and only piezoactuators available worldwide with a 100% ceramic insulation. Conventional piezo actuators are insulated with polymer materials which cannot withstand humidity and other environmental influences as well as ceramics.

Another advantage of PICMA actuators is the extended operating temperature range, up to 150 °C, a huge improvement over the 80 °C limit of other monolithic actuators.

Further information

Request more information about PI Ceramic and the new PICMA actuators.

Application areas for PICMA

- NanoPositioning
- High-speed switches
- Scanning microscopy
- Active optics
- Micropumps
- Microdosage
- Laser tuning
- Biotechnology
- High-speed valves
- Metrology, interferometry

PI Ceramic

Founded 10 years ago, PI Ceramic is a subsidiary of the world's leading supplier of NanoPositioning systems, Physik Instrumente (PI) in Karlsruhe, Germany.

PI Ceramic specializes in the design and production of PZT components, piezoelectric actuators (high-voltage and low-voltage designs), ultrasonic sensors and customized solutions.

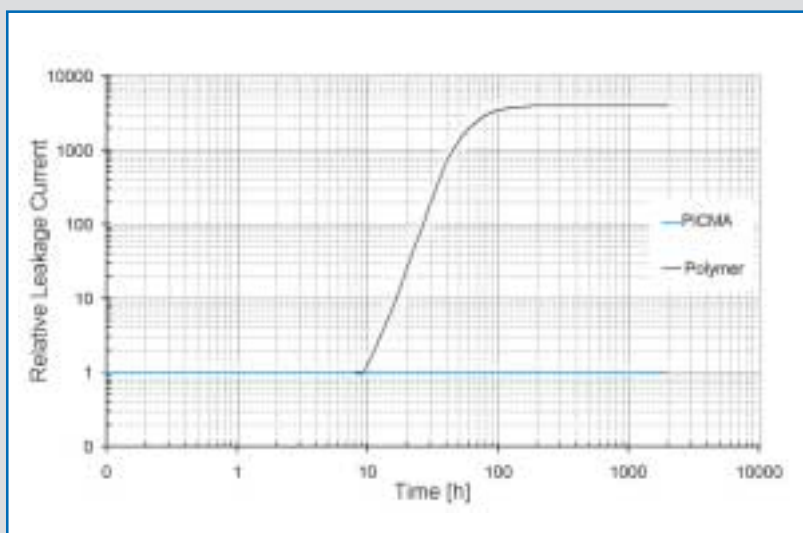

Comparison between PICMA actuators (blue curve) and conventional multilayer actuators with polymer insulation. Under the test conditions, the PICMA actuators exhibited no reaction to high air humidity while conventional actuators exhibit an increased leakage current after only a few hours. The leakage current is an indicator of the quality of the insulation and of the piezoceramic's lifetime. Test conditions $U = 100 \text{ V}_{\text{DC}}$, $T = 25^\circ\text{C}$, rel. humidity = 70 %

100 % vacuum compatible: The DLR (German Space Agency) certifies "no measurable outgassing" rates for PICMA (according to the Micro-VCM/ ESA-PSS-01-702/ATM595 and EC95Q-70-02A standards).

The solution for scanning applications

■ Improve dynamic positioning accuracy by up to 1000 times

Piezo-driven NanoPositioning systems achieve higher resolutions and positioning accuracies than any other positioning systems. And the sub-nanometer region does not represent the limit.

Today there are more and more applications, however, in which high accuracy alone is not sufficient; dynamic accuracy in the nanometer region is what is required. Until now, the limiting factor has been the control technology.

In order to increase throughput, many scanning applications no

longer waste time stopping at the commanded position to record measurement data. Wherever possible, recording is done "on the fly" with the stage in motion.

This means that the NanoPositioning system is only permitted an extremely small tracking error (deviation of the actual from the commanded path), something not possible with conventional P-I-D controllers.

■ Scanning to the nanometer: Dynamic Digital Linearization

With the new E-710 upgrade option "Dynamic Digital Linearization" tracking errors are reduced by a factor of 100 to

1000—to the order of magnitude of a few nanometers.

This new controller operates with all periodic signals (even complex composite scan functions involving several axes). In several "test runs" the controller analyzes the dynamic error and automatically adjusts the parameters so that the tracking error is reduced to a few nanometers. This process typically takes less than a second.

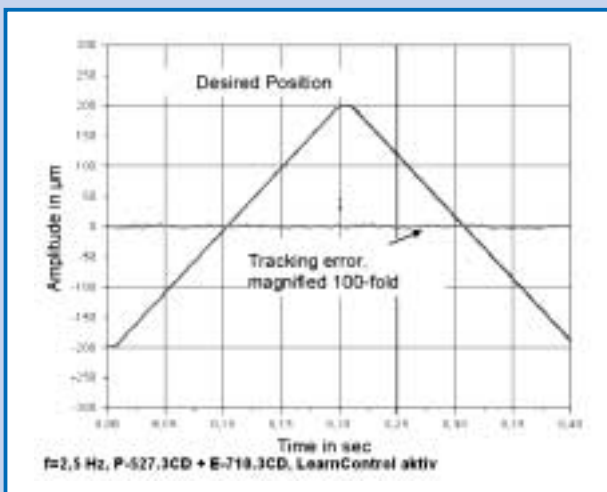
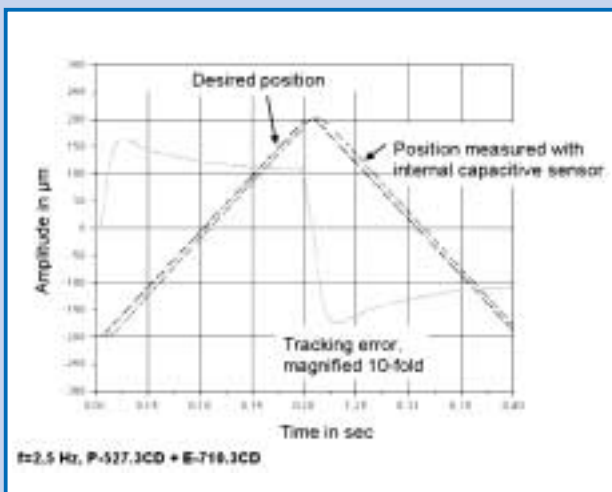

Effect of Digital Linearization on the dynamic positioning accuracy of a Nano-Scan system. The tracking error, shown magnified by 100, was reduced by a factor of 900 compared with conventional a P-I-D controller

Nano-focus-device

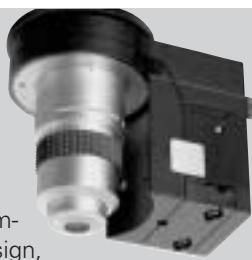

With its improved design, the ultra-high-precision capacitive feedback version of the P-721 PIFOC objective nanopositioner and scanner family can now be equipped with M25 objectives for inverted microscopes. In addition a large variety of other objective thread types and sizes can now also be selected when ordering.

P-721 with capacitive position feedback.

Highlights:

- (Automated) microscope objective adjustment and scan with resolutions <1 nm
- Capacitive feedback for highest linearity and position stability
- Travel to 100 µm
- Fast step-and-settle

Stable positioning of objectives to within a nanometer!

New PI Website provides more information: www.pi.ws

At PI, we recently completely re-designed our Internet presence. At www.pi.ws you can find information on our products, our newsletter, job vacancies as well as our comprehensive tutorials. We hope you will visit our website soon. We welcome your suggestions and comments.

Product page (here: S-334): Diagrams, description, data. Everything can be magnified and is clearly laid out.

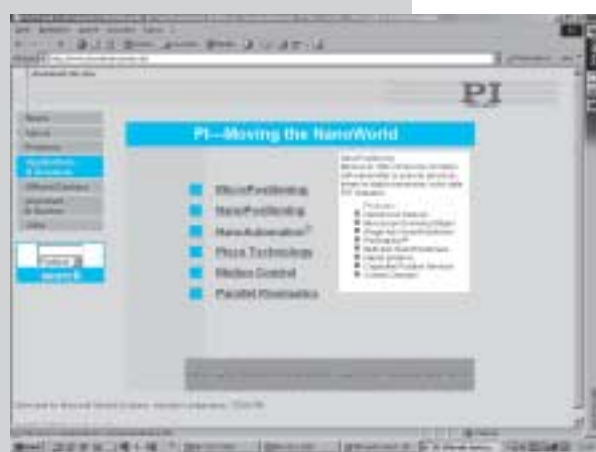

Index of PI's new Internet site: navigation is simple and intuitive.



PIHera Nano-Translation Stages

< 1 nm resolution
0.5 mm travel range

Nanopositioning over 0.5 mm:

P-620 PIHera stages are piezo NanoPositioning systems which combine long travel ranges of up to 500 μm with high-precision motion in the smallest possible package. The large travel ranges are achieved by means of a new type of friction-free, and extremely stiff, lever system which allows high precision and fast step-and-settle.

- Travel ranges up to 500 μm
- Compact dimensions
- < 1 nm resolution
- New piezo drives with increased lifetime
- Capacitive position feedback system for highest possible linearity and repeatability (closed-loop versions)
- 0.01 % positioning accuracy
- Typ. < 5 μrad travel precision
- Low cost
- Vacuum versions available

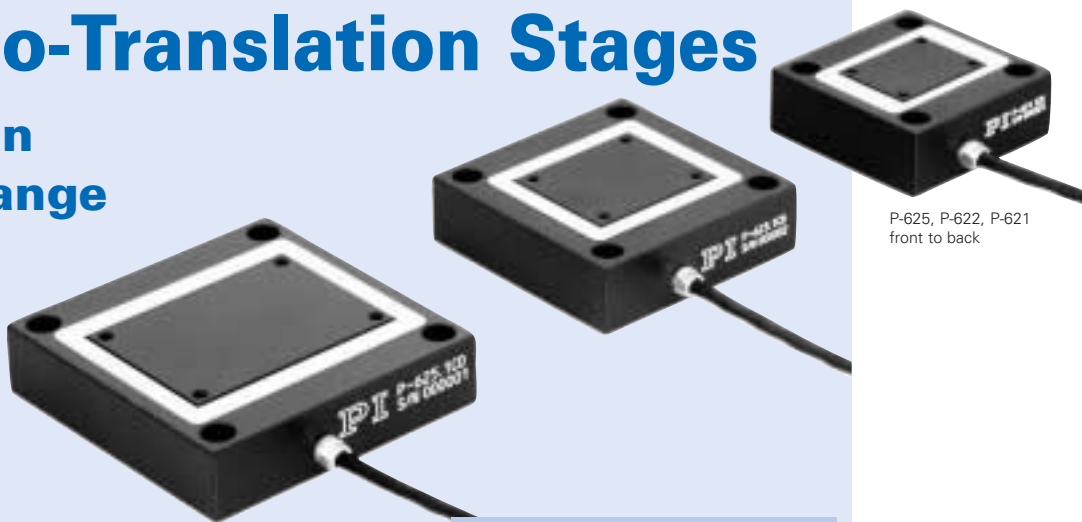

P-625, P-622, P-621
front to back

Order PIHera:

PIHera is available in three versions with or without sensor:

- P-621.1CD / P-621.10L
100 μm travel, dimensions:
40 x 40 x 15 mm^3
- P-622.1CD / P-621.10L
250 μm travel, dimensions:
50 x 50 x 15 mm^3
- P-625.1CD / P-625.10L
500 μm travel, dimensions:
60 x 60 x 15 mm^3

PIHera stages are equipped with PICMA actuators!
(See related article p. 1)

Low-cost solution: PIHera with the new E-665 Controller

Design your own system:

The PIHera operating principle allows flexible designs for customized solutions—from the dimensions and scanning ranges through integrated XY systems to their vacuum compatibility. Ask for further information about the PIHera (P-620) series stages.

Step-and-settle times and scanning with PIHera

In order to squeeze a 500 μm scanning range out of a piezo-driven stage with such compact dimensions, an ingenious lever system is required. PIHera possesses an unrivalled high mechanical stiffness and a correspondingly high resonant frequency for fast step-and-settle times. Optimized for scanning operations, PIHera can be used with the latest digital controllers. For more information, read the article on linearization (p. 2) and ask us for additional material.

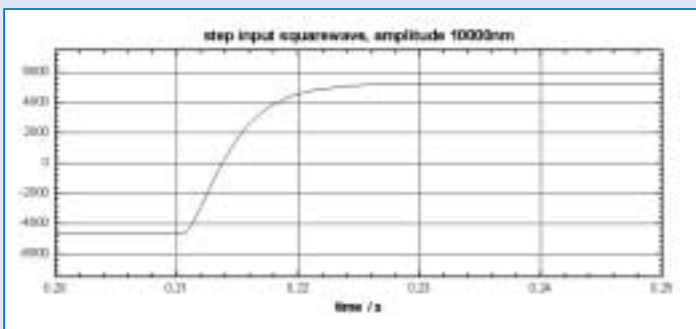

A P-621 (100 μm travel) settles with precision to within 10 nm after < 20 ms (10 μm increment, 15 g load, E-750 controller).

IntelliStep™

A step toward greater flexibility in automation technology

IntelliStep drives: Modular and low-cost automation.
Stepper motor and controller in one!

Advantages:

Reliability: no cable between controller and drive, fewer components, motion unit reduced to one assembly!

Compactness: controller integrated into the motor case!

Network functionality: up to nine IntelliStep motors can be chained together!

Simplicity: the whole network is controlled over one RS-232 interface!

Modularity: manual stages can be retrofitted!

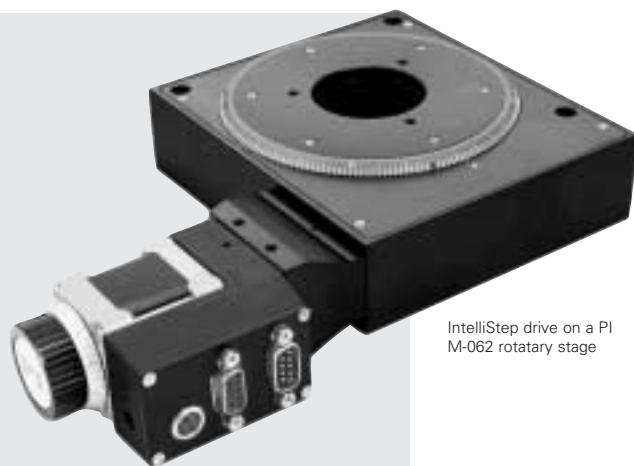

IntelliStep drive on a PI M-062 rotary stage

Compatibility: fully compatible with PI's IntelliStage™ and Apollo stepper motor controller systems, and with PI's micropositioning stages!

PI precision: 20,000 micro-increments/revolution for high resolution and smooth motion!



Motor, controller and amplifier in one package, networkable with up to 9 units.

6D-PKM

"Parallel Kinematic Machine"
opens the way to new applications

With its M-840 Hexapod, PI is extending its lead in the field of 6D parallel kinematics technology for ultra-precise applications even further.

Compared with the (high-load) M-850 Hexapod, the M-840 is distinguished by higher speeds and a lower price.

It therefore makes available the numerous advantages of parallel kinematics to a wider range of customers.

Did you know that PI has been developing Hexapod MicroPositioning systems for more than one decade? Our piezoelectric NanoPositioning systems were using parallel kinematics as early as the 1980s. You can find out more about parallel kinematics at <http://www.parallemic.org>.

- 6 degrees of freedom
- Minimal moment of inertia for fast response
- High stiffness
- No accumulation of runout errors
- Excellent reproducibility of 2 µm, for multi-axis moves
- True path control
- PivotAnywhere™ virtualized center of rotation
- User-friendly software and control electronics

Order further information on the M-840.5PD and M-840.5DG (geared version).

What could your custom Hexapod be able to do?

- Different scanning ranges
- Different size
- Vacuum compatibility (10⁻⁶ hPa)
- Water-resistant

We will design and build a Hexapod just for you!

Why Hexapods?

A significant advantage of parallel kinematics over stacked multi-axis systems consisting of individual stages is the consistently high precision in all axes of motion:

- No moving cables—friction-free and therefore higher precision and reliability
- No accumulation of the runout of the individual axes—reproducibility of a few micrometers
- No cosine error—greater path and positioning precision spatially and about the axes
- No inhomogeneous load distribution—consistent precision about the logical axes

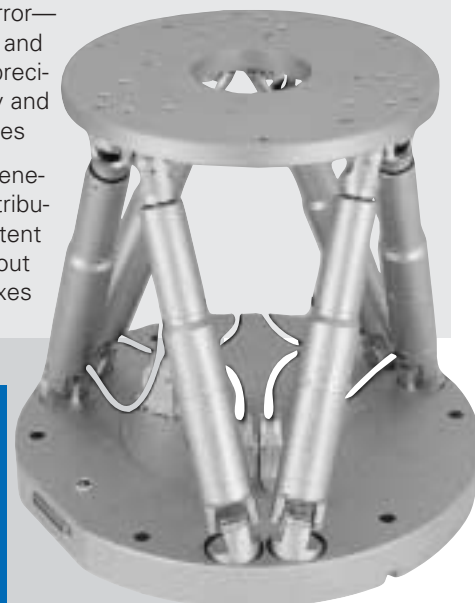

The M-840 Hexapod is the newest member of the PI family of parallel kinematic MicroPositioning systems.

Active tools for rapid machining with nanometer precision

How does one achieve effective out-of-round machining on a lathe or produce a facing with a height profile?

Piezo positioning systems make all this possible. Piezo technology is ideally suited to small, high-precision moves. The PZT material exhibits a high degree of intrinsic stiffness, approaching that of aluminum, even in open-loop operation. In closed-loop operation, the stiffness can be set indefinitely high; it can even be negative, if desired. Or extremely low stiffness values can

be set, meaning that the machine element is virtually allowed to float. In the past, the requirements in the field of precision engineering were expressed in terms of positioning specifications: the system had to reach the required position in milli- or even microseconds. Important was small overshoot, extremely stable position (down to the picometer range) and very low runout (unwanted motion in another dimension). In today's production technology, by contrast, the high positioning accuracy which can be achieved with piezo systems is of secondary importance.

actual path of the workpiece which results from the dynamic error of the positioner). The faster the desired speed of machining, the more significant the tracking error.

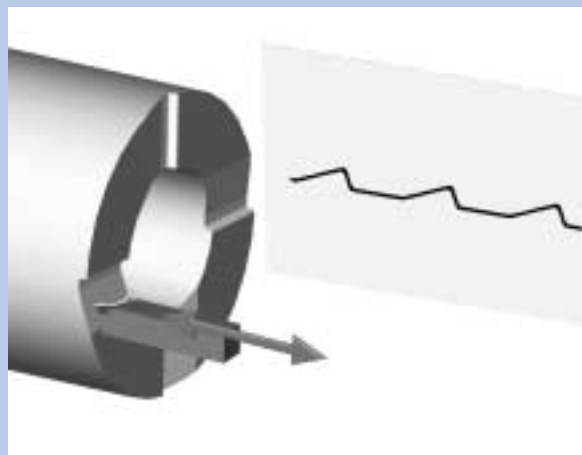

Active tools, Principle of facing with an active controlled jig.

Here, the dynamic characteristics of the positioning system are much more important. Up until now the limiting factor has been the control technology rather than the piezo mechanics; rapid processing led to tracking errors (the tracking error being the deviation between the desired path and the



Piezoelectric tool servo for high-speed out-of-round turning. Travel range +/-125 µm or +/-250 µm.

PI has carried out pioneering work in this field. Its new digital controllers mean that improvements of a factor of 100 and better can be achieved (see the article on the Digital Linearization Controller, p. 2 for details).

AVAILABLE SOON

2003 PI TRADE SHOWS

JANUARY

20 to 23 · NanoTech · Kyoto · Japan
22 to 24 · FiberOptics · Tokyo · Japan
25 to 26 · Biomedical Optics
San Jose, CA · USA
28 to 30 · Photonics West
San José, CA · USA

FEBRUARY

3 to 6 · IMAC · Kissimmee, FL · USA
4 to 6 · Teknik & Data · Odense · Denmark
12 to 13 · IPOT · Birmingham · England

MARCH

4 to 5 · Smart Structures
San Diego, CA · USA
25 to 27 · OFC · Atlanta, GA · USA
25 to 27 · ELKOM · Helsinki · Finland
25 to 28 · Intertronic · Paris · France
27 to 30 · Applied Physics Society,
Kanagawa University · Kanagawa · Japan

APRIL

1 to 3 · Electronica · Tel Aviv · Israel
1 to 3 · Solutions Visions · Paris · France
1 to 3 · Semicon Europe
Munich · Germany
7 to 12 · Hannover Fair
Hannover · Germany
16 to 18 · Motor Technology
Makuhari · Japan

MAY

6 to 8 · Noise & Vibration
Traverse City, MI · USA
6 to 9 · Control · Sinsheim · Germany
6 to 10 · Semicon (SICEC)
Singapore · Singapore

JUNE

2 to 4 · SEM Annual Conference
Charlotte, NC · USA
3 to 5 · CLEO · Baltimore, MD · USA
23 to 25 · Noise-Con
Cleveland, Ohio · USA
23 to 26 · LASER 2003
Munich · Germany
23 to 27 · INFN Meeting · Rome · Italy

JULY

14 to 16 · Reunion Nacional
de Optoelectronica (Optoel)
Madrid · Spain
14 to 16 · Semicon West
San Francisco, CA · USA
13 to 18 · ICOLS 03 · Palm Cove · Australia

AUGUST

27 to 29 · AEL · Helsinki · Finland

SEPTEMBER

2 to 5 · Komponent/Elektronikproduktion
Göteborg · Sweden
9 to 11 · Automaatio · Helsinki · Finland
21 to 25 · ECOC · Rimini · Italy

OCTOBER

8 to 9 · Photonex
Stoneleigh, Coventry · England
7 to 11 · Tekniska Mässan
Stockholm · Sweden
22 to 24 · Opto-Physique · Paris · France
28 to 30 · Electro Optics · Tel Aviv · Israel

NOVEMBER

11 to 14 · Productronica
Munich · Germany
26 to 27 · Mocon
Den Bosch · Netherlands
19 to 21 · Micromachine · Tokyo · Japan

DECEMBER

3 to 5 · Semicon · Tokyo · Japan

NanoPositioning controller for 1 to 12 axes

The E-665 is a new low-cost single-channel controller for piezo NanoPositioning systems equipped with high-resolution capacitive sensors. The controller features both an analog input mode and a fast digital interface which allows up to 12 devices to be networked.



Highlights

- Integrated 20-bit D/A converter and high-speed RS-232 interface
- Network capability with up to 12 channels
- 36 W peak power
- For strain gauge, LVDT or capacitive sensors

The E-665.CR version (for capacitive sensors) combines with the new PIHera Nano-translation stages or PIFOC Nano-Focus-Systems to provide a low-cost, high-performance system.

The M-110 Family

Compact high-resolution micro-positioning stages



The M-110 are compact motorized translation stages which over the years have grown into a complete family of products with a successful market position.

Product-Highlights

- Travel ranges 5, 15 and 25 mm
- Minimum incremental motion 50 nm
- Velocity to 2 mm/s
- Integrated limit and position reference switches
- XY/XYZ mountable
- Hybrid versions with NanoCube™ e.g. for fast fiber alignment tasks

Version overview:

	Travel range	Motor	Drive
M-110.1DG	5 mm	DC	Leadscrew
M-110.2DG	5 mm	DC	Recirculating ballscrew
M-110.12S	5 mm	Stepper	Leadscrew
M-110.22S	5 mm	Stepper	Recirculating ballscrew
M-111.1DG	15 mm	DC	Leadscrew
M-111.2DG	15 mm	DC	Recirculating ballscrew
M-111.12S	15 mm	Stepper	Leadscrew
M-111.22S	15 mm	Stepper	Recirculating ballscrew
M-112.1DG	25 mm	DC	Leadscrew
M-112.2DG	25 mm	DC	Recirculating ballscrew
M-112.12S	25 mm	Stepper	Leadscrew
M-112.22S	25 mm	Stepper	Recirculating ballscrew

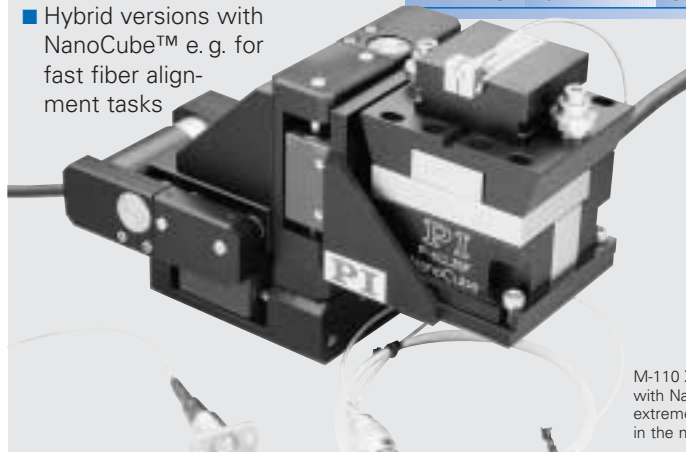

M-110 XYZ-hybrid system with NanoCube™ for extremely fast positioning in the nanometer range.

NEWS BRIEF!

Ultra-long range Scanning or beam-steering about 2 axes in milliseconds, up to $\pm 1.5^\circ$, with sub- μ rad resolution

**World record for a piezo scanner:
 ± 25 mrad**

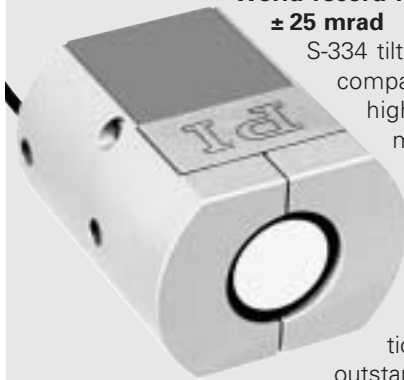

S-334 tilt mirrors are fast and compact units providing highly precise angular motion in two orthogonal axes. The tip/tilt range can be up to ± 25 mrad with a resolution in the sub- μ rad range. In closed-loop operation, the S-334 offers outstanding positioning accuracy and stability.

Highlights

- Tip/tilt range up to ± 25 mrad ($\pm 1.5^\circ$) in 2 fixed orthogonal axes
- 1 kHz resonant frequency with mirror
- For mirrors up to 12.5 mm (0.5") diameter
- Angular resolution in the sub- μ rad range

PUBLISHER

Physik Instrumente (PI) GmbH & Co. KG
Römerstrasse 1 · 76228 Karlsruhe, Germany

Responsible for the contents: Dr. Karl Spanner

Editorial staff: Steffen Arnold, Ed Colaianni

Production: Systemedia, Pforzheim, Germany

Reproduction: Publisher's permission required, source must be cited.
Further information on request.

Coming Soon *Movement & Position 1/2003*

In the next edition of M&P, which is scheduled to appear in Spring 2003, we will present our new, small, power-packed positioning stages.

Attention, AFM users: Do you need a stage no larger than $30 \times 30 \times 30$ mm³ (1.2 in), with > 7 μ m travel, resolution of < 0.1 nm along all three axes and equipped with capacitive feedback sensors? PI has it: speak with us today.

PIline, the drive which moves you, is available as an **OEM drive**. **PIline** refers to our line of piezo linear motors providing unlimited travel with sub-micrometer resolution in a compact package.

In addition, you will be given a preview of the **LASER 2003** in Munich (23–26 June 2003).

C-843 Motion Controller Card Features On-board linear amplifiers & PWM outputs

The new C-843 motion controller card from PI directly drives up to 4 axes of micropositioning equipment without the need for external amplifiers.

Unlike other PCI controller cards, the new C-843 comes with on-board linear amplifiers for the small DC motors used in most compact micropositioning stages and actuators. In addition, PWM outputs are available to drive more powerful equipment (all direct-drive translation and rotation stages from PI feature the integrated ActiveDrive™ PWM amplifiers, and hook up to the C-843 with no external power amplifiers).

For ease of operation, the C-843 is compatible with the PI General Command Set and comes with a comprehensive software package including LabView™ drivers.

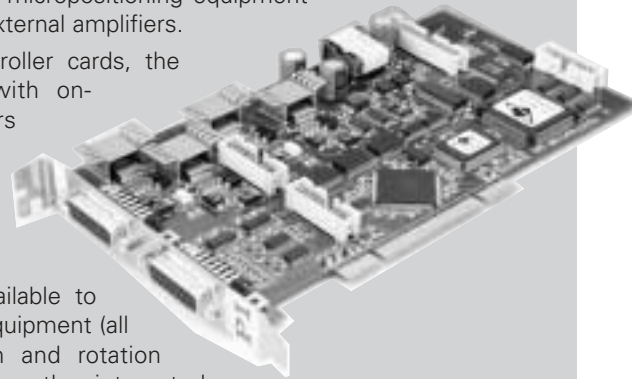

SUBSIDIARIES

USA West (Mexico)
Polytec PI, Inc.
1342 Bell Avenue, Suite 3A
Tustin, CA 92780
USA
Tel: +1 (714) 850 1835
Fax: +1 (714) 850 1831
Email: info@polytepci.com
http://www.polytepci.com

JAPAN
PI-Polytec Co., Ltd.
2-38-5 Akebono-cho
Tachikawa-shi
Tokyo 190-0012
Tel: +81 (42) 526 7300
Fax: +81 (42) 526 7301
Email: info@pi-polytec.co.jp

GREAT BRITAIN
Lambda Photometrics Ltd.
Lambda House
Batford Mill
Harpenden, Hertfordshire
AL5 5BZ
Tel: +44 (1582) 76 43 34
Fax: +44 (1582) 71 20 84
Email: info@lambdaphoto.co.uk
http://www.lambdaphoto.co.uk

USA East (Canada)
Polytec, PI, Inc.
16 Albert St.
Auburn, MA 01501
USA
Tel: +1 (508) 832 3456
Fax: +1 (508) 832 0506
Email: info@polytepci.com
http://www.polytepci.com

JAPAN
PI-Polytec Co. Ltd.
Hanahara Dai-ni Building, #703
4-11-27 Nishinakajima,
Yodogawa-ku, Osaka-shi
Osaka 532-0011
Tel: +81 (66) 6304 5605
Fax: +81 (66) 6304 5606
Email: info@pi-polytec.co.jp

FRANCE
Polytec PI S.A.
32 rue Delizy
F-93694 Pantin Cedex
Tel: +33 (1) 48 10 39 30
Fax: +33 (1) 48 10 08 03
Email: pi.phot@polytec-pi.fr
http://www.polytec-pi.fr

HEADQUARTERS

GERMANY
Physik Instrumente (PI)
GmbH & Co.
Auf der Römerstrasse 1
76228 Karlsruhe
Tel: +49 (721) 4846-0
Fax: +49 (721) 4846-100
Email: info@pi.ws
http://www.pi.ws

GERMANY
PI Ceramic GmbH
Lindenstrasse
07589 Lederhose
Tel: +49 (36604) 882-0
Fax: +49 (36604) 882-25
Email: info@piceramic.de
http://www.pi.ws

New PI Website provides more information:
www.pi.ws

ITALY
Physik Instrumente (PI) S. r. l.
Via E. De Amicis, 2
I-20091 Bresso (MI)
Tel: +39 (02) 665 011 01
Fax: +39 (02) 665 014 56
Email: info@pionline.it
http://www.pionline.it