

C-863 Mercury™ Servo Controller 1-Axis DC-Servo-Motor Controller with Network Feature



- High Performance at Low Cost
- DC Servo-Motor Controller Supplies up to 30 W
- 20 MHz Encoder Input for High Speed & Resolution
- Macro Programmable Stand-Alone Functionality
- Network Capability for Multi-Axis Applications
- Non-Volatile EEPROM for Macros and Parameters
- Digital I/O Lines (TTL)
- Motor-Brake Control
- USB and RS-232 Interface
- Optional Joystick for Manual Control
- Works with All PI Micropositioners

The latest generation Mercury™ C-863 servo motor controller is even more powerful and versatile than its predecessors. Easy data interchange with laptop or PC is possible via the USB interface. The RS-232 interface provides for easy integration in industrial applications. The compact design with its integrated amplifier makes it ideal for building high-performance,

cost-effective micropositioning systems.

Flexible Automation

The Mercury™ offers a number of features to achieve automation and handling tasks in research and industry in a very cost-effective way. Programming is facilitated by the high-level mnemonic command language with macro and compound-command functionality. Macros can be stored in the non-volatile memory for later recall.

Stand-alone capability is provided by a user-programmable autostart macro to run automation tasks at power up (no runtime computer communication required!).

For easy synchronization of motion with internal or external trigger signals four input and four output lines are provided.

Multi-Axis Control, Combination of DC & Stepper Motors

Up to 16 C-863 Mercury™ DC servo controllers and C-663 stepper motor controllers can be daisy-chained and addressed via the same interface.

The networking feature allows the user to start out with one controller and add more units later for multi-axis setups.

Easy Programming

All servo and stepper motor controllers of the Mercury™ family can be operated using the PI general command set (GCS). PI-GCS allows networking of different controller units, both for piezo-based and motorized positioning units, with minimal programming effort. In addition, the C-863 can be programmed using the native command set of previous Mercury™ controllers.

Cost-Saving Due to Integrated Amplifier and PWM Outputs

The unique Mercury™ concept combines a high-performance motion controller and an integrated power amplifier in a small package. Additional PWM control outputs allow the direct operation of any DC-motor-driven PI micro-positioning system—even high-speed stages such as the M-500 ActiveDrive™ Translation Stages—reducing costs, increasing reliability and simplifying the setup.

Contents of Delivery

Each controller is delivered with a wide-range power sup-

Ordering Information

C-863.10
Mercury™ DC-Motor Controller, 1 Channel, with Wide-Range Power Supply

C-819.20
2-Axis Analog Joystick for Mercury™ Controller

C-819.20Y
Y-Cable for Connecting 2 Controllers to C-819.20

C-170.IO
I/O Cable, 2 m, Open End

C-170.PB
Push Button Box, 4 Buttons and 4 LEDs

ply, RS-232 communication cable, a daisy-chain network cable and a comprehensive software package.

Application Examples

- Fiber positioning
- Automation
- Photonics / integrated optics
- Quality assurance testing
- Testing equipment

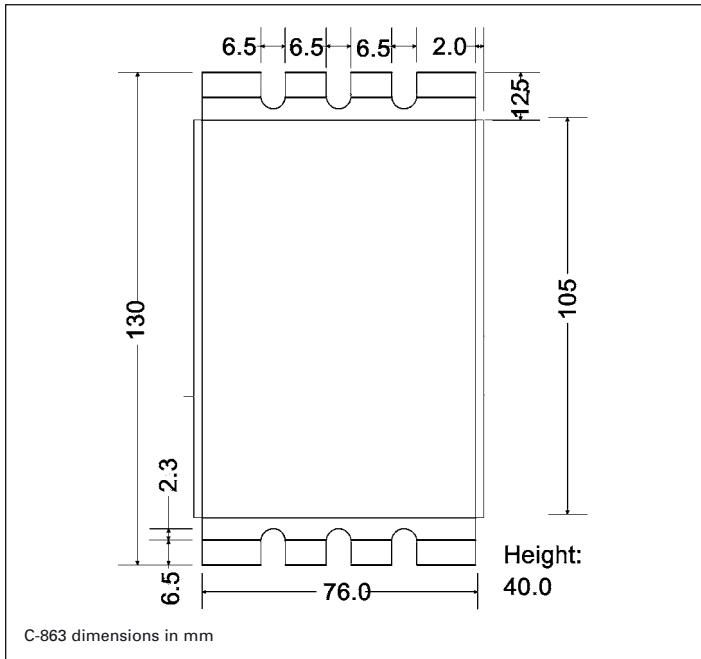

Technical Data

Model	C-863.10
Function	DC-servo-motor controller, 1 channel
Motion and control	
Servo characteristics	P-I-D servo control, parameter change on-the-fly
Trajectory profile modes	Trapezoidal, point-to-point
Encoder input	AB (quadrature) single-ended or differential TTL signal, 20 MHz
Stall detection	Servo off, triggered by programmable position error
Input limit switch	2 x TTL (pull-up/pull-down, programmable)
Input reference switch	1 x TTL
Motor brake	1 x TTL, software controlled
Electrical properties	
Output power	max. 30 W (PWM)
Output voltage	0 to 15 V
Current	80 mA + motor current (3 A max.)
Interfaces and operation	
Communication interfaces	USB, RS-232 (9-pin [m] sub-D)
Motor connector	15-pin (f) sub-D
Controller network	Up to 16 units on single interface
I/O ports	4 analog/digital in, 4 digital out (TTL)
Command set	Mercury Command Set, GCS (via DLL)
User software	PIMikroMove®, MMCRUN
Software drivers	GCS (PI General Command Set)-DLL, LabVIEW drivers, native Mercury™ DLL
Supported functionality	Start-up macro; internal safety circuitry: watchdog timer
Manual control (optional)	2-axis joystick, Y-cable for 2D motion, pushbutton box
Miscellaneous	
Operating voltage	15 to 30 V included: external power supply, 15 V / 2 A
Operating temperature range	+5 to +50 °C
Mass	0.3 kg
Dimensions	130 x 76 x 40 mm

Linear Actuators & Motors

Nanopositioning / Piezoelectrics

Nanometrology

Micropositioning

Hexapod 6-Axis Systems /
Parallel Kinematics

Linear Stages

Translation (X)

Vertical (Y)

Multi-Axis

Rotary & Tilt Stages

Accessories

**Servo & Stepper
Motor Controllers**

Single-Channel

Hybrid

Multi-Channel

Micropositioning
Fundamentals

Index