

M-116 Precision Rotation Stage

Compact, Multi-Axis Combinations with M-110 Translation Stage Series

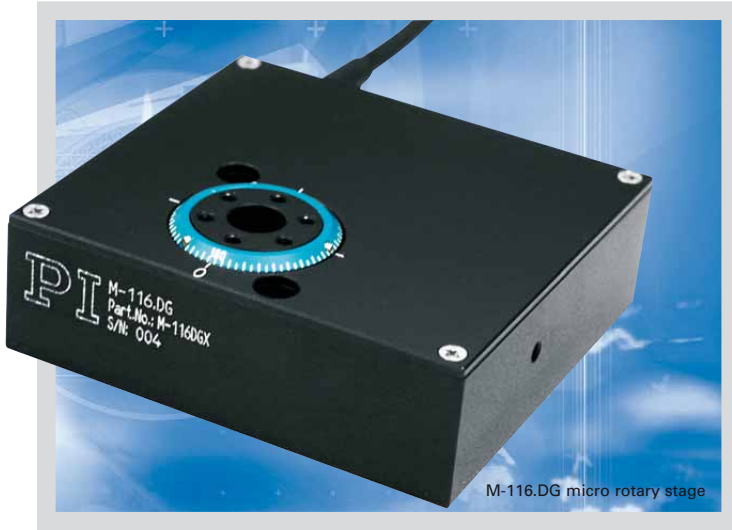

M-116.DG micro rotary stage

- Compact Design
- Continuous Rotation Range
- Encoder Resolution 2.5 μ rad
- Clear Aperture
- Max. Velocity 20 degrees/second
- Preloaded Worm Drive for Zero Backlash
- Fits Directly on M-110 Micro Translation Stages
- Non-Contact Reference Switch
- Repeatability to ± 10 μ rad

M-116 rotation stages are equipped with low-friction, spring-preloaded worm gear drives allowing unlimited rotation in either direction in an extremely compact package.

Stepper and Servo Motors

Both drive options provide a cost-effective solution for industrial and OEM environ-

ments. A miniature DC or stepper motor actuates motion via a spring-preloaded worm gear drive and zero-backlash (with M-116.xxH versions) gearhead.

To meet the most critical positioning demands, the DC motor is equipped with a high-resolution encoder featuring resolution of 2048 counts per revolution. The combination of the extremely low-stiction/low-friction construction and high-resolution encoder allows for minimum incremental motion of 25 μ rad at speeds up to 20 degrees/second.

Multi-Axis Combinations

M-116 rotary stages can be combined with the M-110, M-111 and M-112 micro linear stages without an additional

adapter plate to keep the total height at a minimum.

Clear Aperture, Lens Adapter

The M-116 is designed with a clear aperture for extended versatility in optics applications. The M-116.AL1 lens adapter is available to accommodate 0.5" optics such as polarizers.

Non-Contact Limit and Reference Switches

Motorized models are equipped with an integrated Hall-effect origin switch. To protect your equipment and increase versatility in automation applications, the rotary stage can optionally be equipped with Hall-effect limit switches. Travel can be limited to a range between 0° and 330° $\pm 2^\circ$.

For ease of operation and setup, all models come with a scale ring on the outer edge of the turntable.

Ordering Information

M-116.DG

Rotation Stage, 360°, Closed-Loop DC Motor Gearhead

M-116.DGH

Rotation Stage, 360°, Closed-Loop Backlash-Free DC Motor Gearhead

M-116.2SH

Rotation Stage, 360°, 2-Phase Stepper Motor with Backlash-Free Gearhead

M-116.AL1

Lens Adapter for 0.5" Optics

Ask about custom designs!



XY θ_z micropositioning combination consisting of (from top to bottom) M-116 micro rotary stage and two M-111 translation stages (M-110.01 adapter for mounting the M-111 on a honeycomb breadboard with M6 on 25 mm centers)

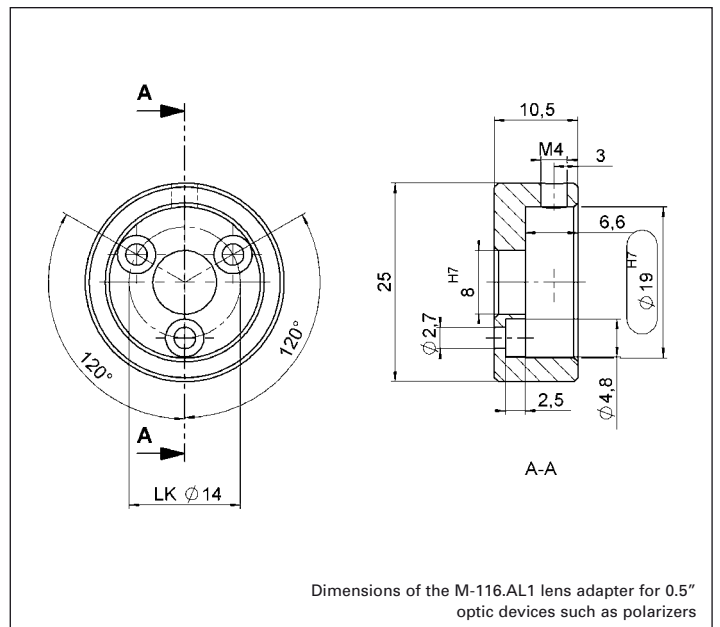

Dimensions of the M-116.AL1 lens adapter for 0.5" optic devices such as polarizers

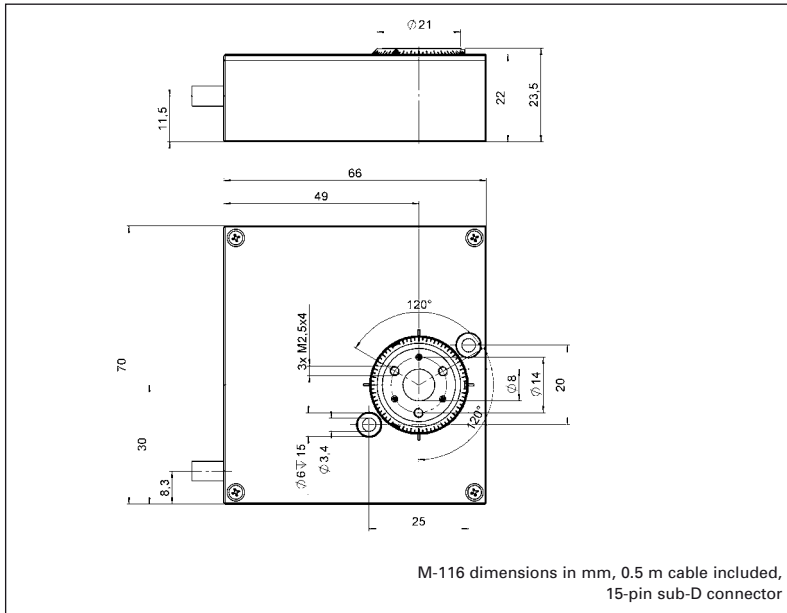

Technical Data

Model	M-116.DG	M-116.DGH	M-116.2SH	Units
Active axes	Rotation	Rotation	Rotation	
Motion and positioning				
Rotation range	>360	>360	>360	°
Integrated sensor	Rotary encoder	Rotary encoder	–	
Sensor resolution	2048	2048	–	Cts./rev.
Design resolution	2.45 (0.00013)	3.16 (0.00018)	16.9* (0.00097)	μrad (°)
Min. incremental motion	50	25	30	μrad
Backlash	1000	500	500	μrad
Unidirectional repeatability	12	10	10	μrad
Max. velocity	20	20	20	°/s
Mechanical properties				
Worm gear ratio	44:1	44:1	44:1	
Gear ratio	28.444:1	22.0335:1	22.0335:1	
Motor resolution	–	–	384*	steps/rev.
Axial force	±15	±15	15	N
Max. Torque (θ_x , θ_y)	±1.5	±1.5	±1.5	Nm
Max. Torque clockwise (θ_z)	0.4	0.4	0.4	Nm
Max. torque counterclockwise (θ_z)	0.8	0.8	0.8	Nm
Drive properties				
Motor type	DC-motor, gearhead	DC-motor, gearhead	2-phase stepper motor*	
Operating voltage	0 to ±12	0 to ±12	24	V
Electrical power	1.75	1.75		W
Reference switch	optical	optical	optical	
Miscellaneous				
Operating temperature range	-20 to +65	-20 to +65	-20 to +65	°C
Material	Aluminum	Aluminum	Aluminum	
Mass	0.4	0.4	0.4	kg
Recommended controller/driver	C-863 single-axis C-843 PCI board, for up to 4 axes	C-863 single-axis (p. 4-114) C-843 PCI board (p. 4-120), for up to 4 axes	C-663 single-axis (p. 4-112)	

*2-phase stepper motor, 24 V chopper voltage, max. 0.25 A/phase, 24 full steps/rev., motor resolution with C-663 stepper motor controller

Linear Actuators & Motors

Nanopositioning / Piezoelectrics

Nanometrology

Micropositioning

Hexapod 6-Axis Systems /
Parallel Kinematics

Linear Stages

Translation (X)

Vertical (Y)

Multi-Axis

Rotary & Tilt Stages

Accessories

Servo & Stepper
Motor Controllers

Single-Channel

Hybrid

Multi-Channel

Micropositioning
Fundamentals

Index