

M-122 Precision Micro-Translation Stage

Fast & Compact with Direct Position Measurement



The M-122.2DD miniature translation stage features an optical linear encoder with 0.1 µm position resolution and a highly efficient ballscrew

- Travel Range 25 mm
- 0.1 µm Optical Linear Encoder for Highest Accuracy & Repeatability
- Min. Incremental Motion to 0.2 µm
- Max. Velocity 20 mm/s
- Cross-Roll Bearings
- Recirculating Ball Screw Drives Provide High Speeds & Long Lifetimes

The M-122 palm-top-sized translation stage combines small dimensions, high speeds and very high accuracy at a competitive price. It features a space-saving, folded drive train with the servo motor and drive screw side-by-side. Equipped with a non-contacting optical linear encoder and a preloaded, precision-ground, ball-screw, these stages can provide much higher accuracy and better repeatability than conventional stepper motor stages or rotary encoder-equipped servo motor stages.

Low Friction, High Speed, Maintenance-Free

Due to its low-friction, the backlash-free ball screw yields significantly higher mechanical

efficiency than leadscrews, and allows maintenance-free, high duty-cycle operation at high velocities up to 20 mm/sec.

XY and XYZ Combinations

M-122 stages can be combined to very compact XY and XYZ systems. The M-122.AP1 mounting bracket is available to mount the Z-axis.

Limit and Reference Switches

For the protection of your equipment, non-contact Hall-effect limit and reference switches are installed. The direction-sensing reference switch supports advanced automation applications with high precision.

Low Cost of Ownership

The combination of these positioners with the networkable, single-channel C-863 Mercury™ servo motor controller (s. p. 4-114) offers high performance for a very competitive price in both single- and multi-axis configurations. For multi-axis applications, the C-843 PC plug-in controller board with on-board servo amplifiers (s. p. 4-120) is another cost-effective alternative.

Ordering Information

M-122.2DD
High-Precision Translation Stage, 25 mm, Direct-Drive DC Motor, Ballscrew

Accessories

M-122.AP1
Angle bracket for vertical mounting of M-122 stages
Ask about custom designs

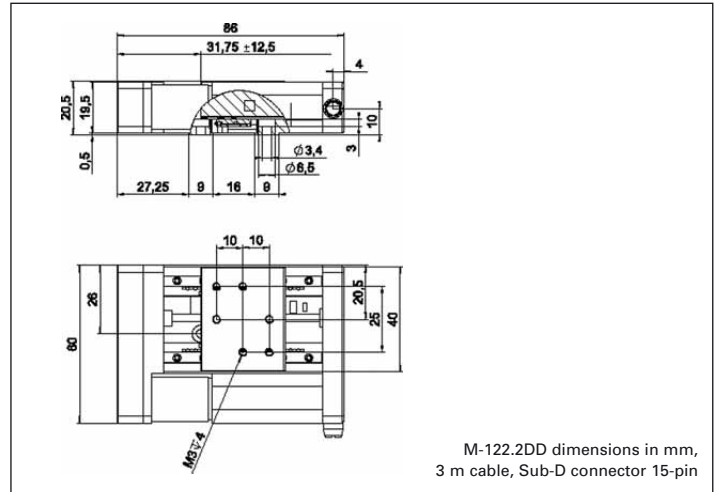

M-122.2DD dimensions in mm, 3 m cable, Sub-D connector 15-pin

Technical Data

Model	M-122.2DD
Active axes	X
Motion and positioning	
Travel range	25 mm
Integrated sensor	Linear encoder
Sensor resolution	0.1 µm
Design resolution	0.1 µm
Min. incremental motion	0.2 µm
Backlash	0.2 µm
Unidirectional repeatability	0.15 µm
Pitch	±150 µrad
Yaw	±150 µrad
Max. velocity	20 mm/s
Origin repeatability	1 µm
Mechanical properties	
Drive screw	Recirculating ballscrew
Thread pitch	0.5 mm
Stiffness in motion direction	0.25 N/µm
Max. load	50 N
Max. push/pull force	20 N
Max. lateral force	25 N
Drive properties	
Motor type	DC motor
Operating voltage	0 to ±12 V
Electrical power	2.25 W
Limit and reference switches	Hall-effect
Miscellaneous	
Operating temperature range	-20 to +65
Material	Aluminum, steel
Dimensions	86 x 60 x 20.5 mm
Mass	0.22 kg
Recommended controller/driver	C-863 (single-axis) C-843 PCI board (up to 4 axes)

Application Examples

- Photonics packaging
- Fiber positioning
- Metrology
- Quality assurance testing
- Testing equipment
- Micromachining