

# M-232 DC-Mike Precision Linear Actuator

## Compact Package, Suitable for Fiber Alignment



- Travel Range 17 mm
- Min. Incremental Motion to 0,1 µm
- Max. Velocity 2,5 mm/s
- Closed-Loop DC-Motors
- Non-Contact Limit and Reference Switches
- Fits M-105 Fiber Aligners
- MTBF >5.000 h

The M-232 is an ultra-high-resolution linear actuator providing linear motion up to 17 mm with sub-micron resolution in a compact package. It features a space-saving design with a leadscrew side-by-side to a closed-loop DC-motor/gear-head combination and a high-resolution encoder (2048 counts/rev.). They feature a low-stiction, low-friction construction allowing for minimum incremental motion of 100 nanometers at speeds of up to 2.5 mm/sec.

### Upgrade for Manual Aligners

The M-232 was especially designed to fit existing manual translation stages (e.g. M-105 see p. 4-50 ff) as a direct replacement for a manual micrometer.

### Application Examples

- Fiber positioning
- Metrology
- Photonics packaging
- Quality assurance testing
- Testing equipment

### Limit and Reference Switches

For the protection of your equipment, non-contact Hall-effect limit and reference switches are installed. The reference switch supports advanced automation applications with high precision.

### Integrated Line Drivers

All actuators include an integral 0.5 m cable with 15-pin sub-D connector and come with a 3 m extension cable. On the DC servo versions, the connector features integrated line drivers for cable lengths up to 10 meters between actuator and controller.

For higher loads and travel ranges, refer to the M-230 (see p. 1-46), M-235 (see p. 1-50) and M-238 (see p. 1-52).

### Ordering Information

**M-232.17**  
Compact High-Resolution DC-Mike Linear Actuator, 17 mm, Limit Switches

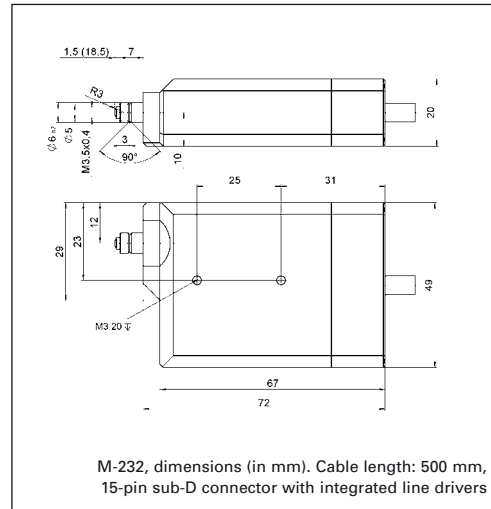

### Technical Data

Model	M-232.17	Units
Active axes	X	
<b>Motion and positioning</b>		
Travel range	17	mm
Integrated sensor	Rotary encoder	
Sensor resolution	2,048	Cts./rev.
Design resolution	0.007	µm
Min. incremental motion	0.1	µm
Backlash	2	µm
Unidirectional repeatability	0.2	µm
Max. velocity	1.5	mm/s
Reference switch repeatability	1	µm
<b>Mechanical properties</b>		
Spindle	Leadscrew	
Spindle pitch	0.4	mm
Gear ratio	28.44444:1	
Max. push/pull force	40	N
<b>Drive properties</b>		
Motor type	DC-motor, gearhead	
Operating voltage	0 to ±12	V
Electrical power	2	W
Limit and reference switches	Hall-effect	
<b>Miscellaneous</b>		
Operating temperature range	-20 to +65	°C
Material	Al (anodized), steel	
Mass	0.17	kg
Recommended controller/driver	C-863 single-axis (p. 4-114) C-843 PCI board, for up to 4 axes (p. 4-112)	

### Linear Actuators & Motors

PiezoWalk® Motors / Actuators

PILine® Ultrasonic Motors

### DC-Servo & Stepper Actuators

Piezo Actuators & Components

Guided / Preloaded Actuators

Unpackaged Stack Actuators

Patches/Benders/Tubes/Shear..

### Nanopositioning / Piezoelectrics

Nanometrology

Micropositioning

Index