

M-238 High-Load, High-Resolution Linear Actuator Forces to 400 N, Optional Direct Position Measurement



M-238.5PL Heavy-Duty Mike actuator (with CD for size comparison)

- High Load Capacity to 400 N
- Travel Range 50 mm
- Resolution to 0.1 μm
- Max. Velocity 30 mm/s
- Preloaded Frictionless Ball Screw
- Optional 0.1 μm Direct-Metrology Linear Encoder for Exceptional Precision
- MTBF >20,000 h
- Vacuum-Compatible Versions Available for 10^{-6} hPa

The M-238 is a high-load, high-precision actuator providing linear motion up to 50 mm, a load capacity to 400 N and high velocity to 30 mm/s. It consists of a low-friction, heavy-duty ballscrew, driven by a closed-loop, ActiveDrive™ DC-Motor with gearbox. The M-238 is therefore well suited for high duty-cycle operation in industrial environments. An optional linear encoder provides exceptional accuracy and repeatability.

Direct Metrology Linear Encoder to Compensate Mechanical Play

The M-238.5PL model is equipped with a non-contact, optical, linear encoder (direct metrology) with an output resolution of 0.1 μm . Because the encoder measures the actual position of the non-rotating actuator tip, drive-train errors like backlash and elastic deformations are eliminated. A lower-cost version with a rotary encoder is available as model number M-238.5PG.

ActiveDrive™ DC-Motor

DC motor drives offer several advantages, such as high dynamics, high torque at low rotational speed, low heat and low vibration.

The ActiveDrive™ design, developed by PI, features a

high-efficiency PWM (pulse width modulation) servo-amplifier mounted side-by-side with the DC-Motor and offers several advantages:

- Increased efficiency, by eliminating power losses between the amplifier and motor
- Reduced cost of ownership and improved reliability, because no external driver is required
- Elimination of PWM amplifier noise radiation, by mounting the amplifier and motor together in a single, electrically shielded case

Non-Rotating Tip

Compared to conventional rotating-tip micrometer drives, the non-rotating-tip design offers several advantages:

- Elimination of torque-induced positioning errors
- Elimination of sinusoidal motion errors
- Elimination of wear at the contact point
- Elimination of tip-angle dependent wobble

The lateral guiding of the tip withstands lateral forces of up to 100 N.

Ordering Information

M-238.5PG
Heavy-Duty DC-Mike Actuator, 400 N, 50 mm, ActiveDrive™

M-238.5PL*
Heavy-Duty DC-Mike Actuator, 400 N, 50 mm, ActiveDrive™, Direct-Metrology Encoder

*Ask for availability in your region

Ballscrews for High Speed, Precision and Lifetime

The precision-ground ballscrew is maintenance-free and preloaded to eliminate mechanical play. Its significantly reduced friction, compared to conventional leadscrews, allows for higher velocity, lower power consumption and longer lifetime.

Limit and Reference Switches

For the protection of your equipment, non-contact Hall-effect limit and reference switches are installed. The direction-sensing reference switch supports advanced automation applications with high precision.

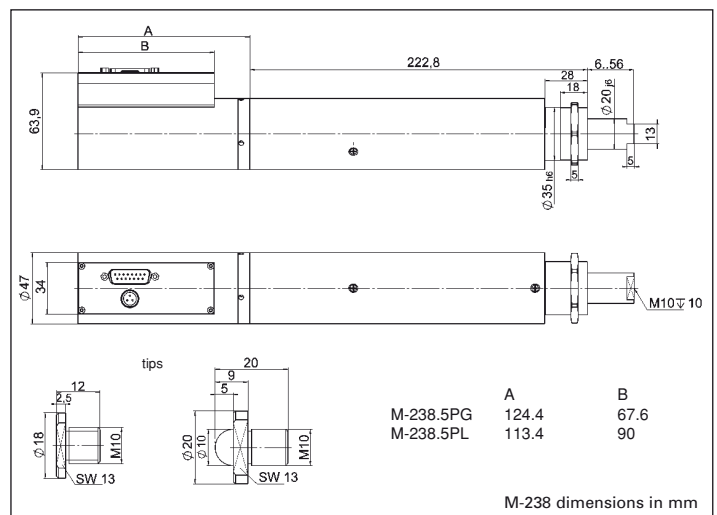

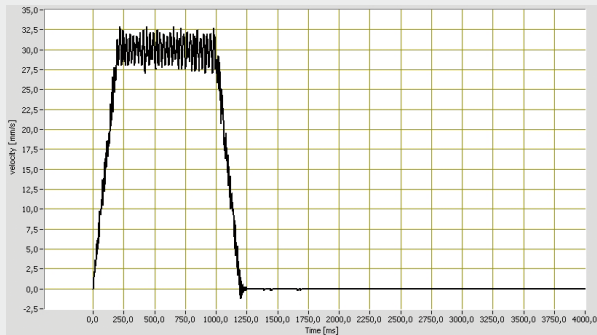

M-238.5PL velocity at 30 mm/s is highly constant.

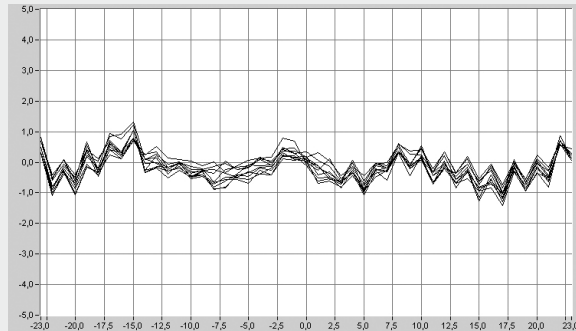
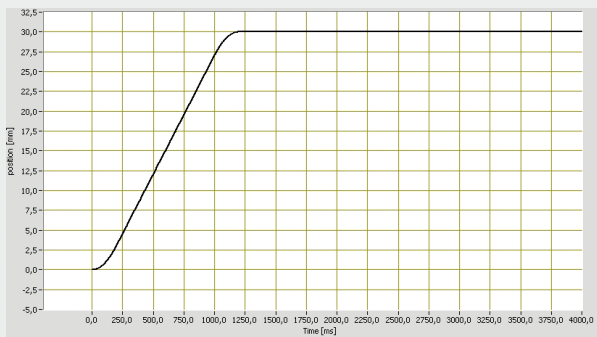

M-238.5PL repeatability is better than 0.3 μm .

The settling time for a 30 mm step is less than 1.5 seconds.

Linear Actuators & Motors

PiezoWalk® Motors / Actuators

PILine® Ultrasonic Motors

DC-Servo & Stepper Actuators

Piezo Actuators & Components

Guided / Preloaded Actuators

Unpackaged Stack Actuators

Patches/Benders/Tubes/Shear..

Nanopositioning / Piezoelectrics

Nanometrology

Micropositioning

Index

Technical Data

Model	M-238.5PG	M-238.5PL	Units	Tolerance
Active axes	X	X		
Motion and positioning				
Travel range	50	50	mm	
Integrated sensor	Rotary encoder	Linear encoder		
Sensor resolution	4000 cts/rev.	0.1 μm		
Design resolution	0.13	0.1	μm	typ.
Min. incremental motion	0.5	0.3	μm	typ.
Backlash	3	1	μm	typ.
Unidirectional repeatability	1	0.3	μm	typ.
Max. velocity	30	30	mm/s	
Origin repeatability	1	1	μm	$\pm 20\%$
Mechanical properties				
Spindle pitch	2	2	mm/rev.	
Gear ratio	3.71:1	3.71:1		
Push/pull force	400	400	N	Max.
Lateral force	100	100	N	Max.
Drive properties				
Motor type	DC-motor, ActiveDrive™	DC-motor, ActiveDrive™		
Operating voltage	24 (PWM)	24 (PWM)	V	
Electrical power	80	80	W	nominal
Miscellaneous				
Operating temperature range	-10 to 50	-10 to 50	°C	
Material	Al (anodized), steel	Al (anodized), steel		
Mass	2.4	2.4	kg	$\pm 5\%$
Cable length	3	3	m	$\pm 10\text{ mm}$
Connector	D-Sub 15 (m)	D-Sub 15 (m)		
Recommended controller/driver	C-863, C-843	C-863 (p. 4-114), C-843 (p. 4-120)		