

N-110

NEXLINE® Miniature High-Load Piezo Nanopositioning Drive



N-110 high-load OEM actuator for nanopositioning

- Winner of the SEMI Technology Innovation Showcase Award
- 3 mm Travel Range
- <0.1 nm Resolution (Open-Loop)
- Active Force Generation to 30 N
- >50 N Holding Force
- Self-Locking

The novel, patented NEXLINE® drive design combines long travel ranges (hundreds of millimeters) with high stiffness and high resolution (better than 0.1 nm). Coordinated motion of shear and longitudinal piezo elements is what allows NEXLINE® to break away from the limitations of conventional Nanopositioning actuators. NEXLINE® motion is possible in two different modes: a high-resolution, high

dynamics analog mode, and a step mode with theoretically unlimited travel range.

NEXLINE® OEM Drives Offer Complete Flexibility

NEXLINE® drives can be used wherever high loads must be positioned with very high precision and perhaps given small, dynamic adjustments (e.g. active vibration control). By fine-tuning the combination of shear and longitudinal actuator motion, the incremental motion (analog-mode travel range), holding force and stiffness can be controlled directly. In NEXLINE® OEM drives, the clamping and shear elements press against a slider, which is appropriately linked to the moving part of the application. If the application does not provide its own position signal, the NEXLINE® drives can be equipped with internal position

sensors, like, for example high-resolution capacitive or incremental sensors.

High-Resolution Dynamic Operation

In the analog mode, motion is provided by the high-stiffness shear piezo elements. The resonant frequency in the direction of motion is as high as 2 kHz. The settling-time in the analog mode is typically less than 10 ms. The position resolution depends only on the amplifier noise and, in a closed-loop system, on the sensor.

Basically Unlimited Travel Range

Step mode is effectuated with a sequence of shear and clamping motions. The step frequency can reach 100 Hz and, depending on the step size, speeds of up to 0.5 mm/s can be achieved.

Unlimited Lifetime

NEXLINE® actuators can often be found in inaccessible locations deep inside complex equipment, where nanometer-precise alignment and vibration-cancelation are required. This makes long lifetime for NEXLINE® actuators an absolute necessity. The drive

Technical Data

Models	N-110.00
Travel range in step mode	3 mm
Maximum step size in step mode	1.5 µm
* Maximum step frequency	100 Hz
* Maximum speed	0.15 mm/s
Travel range in analog mode	0.8 µm
** Resolution (open-loop) in analog mode	<0.1 nm
Holding force (passive)	>50 N
Push/pull force (active)	30 N
Stiffness in motion direction	15 N/µm
Max. Operating voltage [V]	±250 V
Recommended controller	E-755

* depends on control electronics
 ** Resolution of Piezo nanopositioners is not limited by friction or stiction.
 Sub- 0.1 nanometer resolution can be achieved with a low noise amplifier.

Ordering Information

N-110.00
 NEXLINE® OEM Nanopositioning Drive, 3 mm, 30 N

can always be brought to a condition with zero-voltage on the individual piezo elements and with the full holding force available, no matter where it is along its travel range. This eliminates long-term offset voltages, which limit the lifetime of piezos.

Notes

NEXLINE® actuators are especially well-suited for the following environments:

- Cleanrooms
- Vacuum
- In conditions which do not permit use of drives with magnetic parts

The NEXLINE® drive principle is covered by:
 US Pat.-No.: 6,800,984

Application Example

- Metrology
- Semiconductor manufacturing
- Quality control in the semiconductor industry
- Beamline-/cavity tuning
- Alignment in high magnetic fields

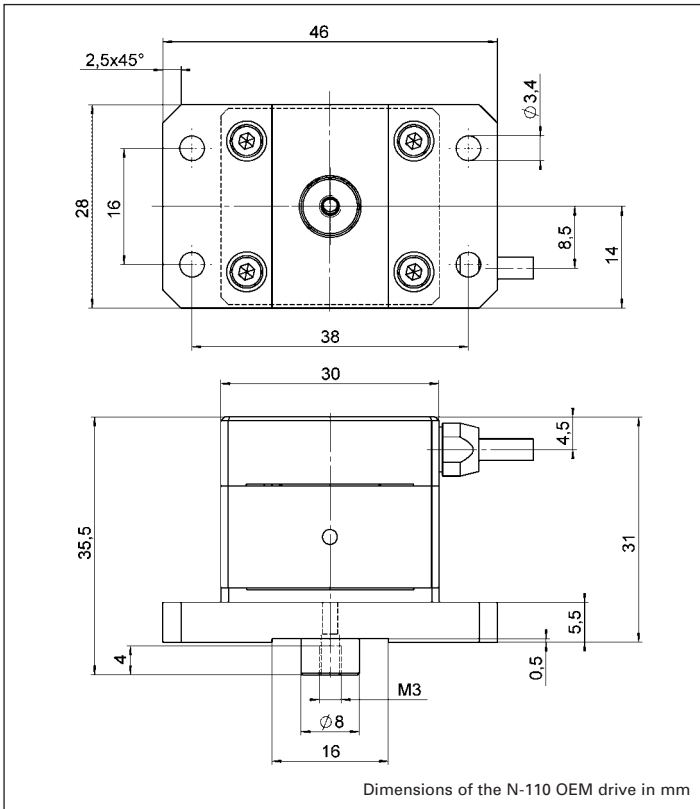

Piezo Actuators

Nanopositioning & Scanning Systems

Active Optics / Steering Mirrors

Tutorial: Piezo-electrics in Positioning

Capacitive Position Sensors

Piezo Drivers & Nanopositioning Controllers

Hexapods / Micropositioning

Photonics Alignment Solutions

Motion Controllers

Ceramic Linear Motors & Stages

Index