

N-310 NEXACT® OEM Miniature Linear Motor/Actuator

Compact, High-Speed PiezoWalk® Drive



- 20 mm Standard Travel Range, Flexible Choice of the Runner Length
- Compact and Cost-Effective Design
- 0.03 nm Resolution**
- To 10 N Push/Pull Force
- Low Operating Voltage
- Self Locking at Rest, No Head Dissipation, Nanometer Stability
- Non-Magnetic and Vacuum-Compatible Working Principle

N-310 NEXACT® PiezoWalk® linear drives feature travel ranges of 20 mm and push/pull force capacities to 10 N in a compact package of only 25 x 25 x 12 mm. With their high resolution, NEXACT® drives, are ideal for high-precision positioning over long travel ranges.

Application Examples

- Semiconductor technology
- Wafer inspection
- Nano lithography
- Surface Measurement Technique
- Profilometry
- Microscopy
- Motion in strong magnetic fields

The N-310 can be operated in open-loop and closed-loop mode (with the addition of an external position sensor). A variety of NEXACT® controllers facilitates the integration into micro- or nanopositioning applications.

Advantages of PiezoWalk® Piezo Stepping Drives

NEXLINE® and NEXACT® drives offer several advantages over traditional drive technologies:

- Resolution in the picometer range
- Compact dimensions
- High drive forces from ten newtons (NEXACT®) up to several hundred newtons (NEXLINE®)
- High-dynamics performance with sub-microsecond response

- Self-locking when powered down; no holding current
- Zero backlash, no wear or maintenance, no mechanical components like gears or leadscrews.
- Non-Magnetic and Vacuum Compatible Operating Principle

Working Principle for Application Flexibility

NEXACT® PiezoWalk® technology overcomes the limitations of conventional nanopositioning drives and combines virtually unlimited travel ranges with high stiffness in a very small package. Furthermore, NEXACT® actuators provide piezo-class resolution (far below one nanometer) and millisecond responsiveness. The special drive design reduces the operating voltage to 45 V and below.

In operation, piezoceramic bending elements act on the runner, which is connected to the moving part of the application. The length of the runner determines the travel range. Force capacity, resolution and velocity are determined by the piezo geometry and drive electronics and are scalable. To move the runner over longer distances the stepping mode is used, whereas for distances smaller than one step, the linear (analog) mode enables high-dynamics positioning with resolutions far below one nanometer.

Wear- and Maintenance-Free

In contrast to ordinary DC or stepper motor drives, the PiezoWalk® drives effect linear motion directly, without the need to transform rotation with mechanical elements such as gears, leadscrews and nuts. Therefore, mechanical

Ordering Information

- N-310.11**
NEXACT® OEM linear drive, 20 mm, 10 N
 - N-310.111**
NEXACT® OEM linear drive, 20 mm, 10 N, Shifted Cable Exit
- Ask about custom designs**

limitations such as backlash and wear are eliminated and the drive is maintenance-free.

Self-Locking PiezoWalk® Piezo Stepping Drive

NEXLINE® and NEXACT® exhibit high stiffness and are self-locking even when powered down due to the clamping action of the piezo actuators in the mechanics. This entails nanometer position stability at rest, with no heat dissipation or servo-dither.

Controller and Drive Electronics Optimized for the Application

NEXACT® actuators require special drive electronics to control the complex stepping sequences. The E-860 series NEXACT® controllers are available in different open and closed-loop versions. For example, the E-861 includes a complete NEXACT® servo-controller with low-noise, 24-bit drivers and a powerful DSP. It also comes with ample software for easy integration and highly effective computer control. For applications which do not require the highest resolution lower-priced drive electronics, ranging all the way to OEM boards, can be ordered.

The products described in this document are in part protected by the following patents: German Patent No. P4408618.0

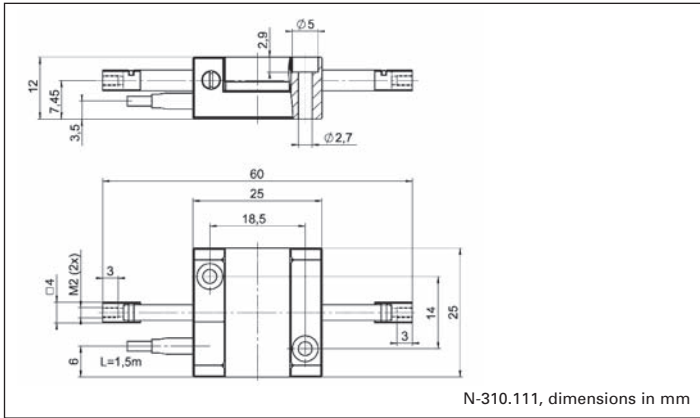
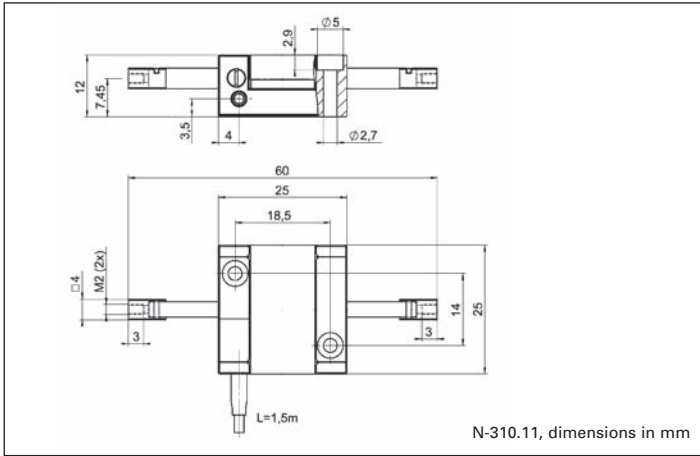

Linear Actuators & Motors

PiezoWalk® Motors / Actuators

PLine® Ultrasonic Motors

DC-Servo & Stepper Actuators

Piezo Actuators & Components

Guided / Preloaded Actuators

Unpackaged Stack Actuators

Patches/Benders/Tubes/Shear...

Nanopositioning / Piezoelectrics

Nanometrology

Micropositioning

Index

Technical Data

Model	N-310.11, N-310.111	Tolerance
Active axes	X	
Motion and positioning		
Travel range	20 mm	
Step size (in step mode)	5 nm to 5 µm	
Travel range in analog operation	7 µm	max.
Open-loop resolution	0.03 nm**	typ.
Step frequency	1.5 kHz*	max.
Max. speed	10 mm/s*	max.
Mechanical properties		
Push/Pull force (active)	10 N	max.
Drive properties		
Drive type	NEXACT® linear drive	
Operating voltage	-10 V to +45 V	
Miscellaneous		
Operating temperature range	0 to 50 °C	
Body material	Stainless steel, non-magnetic	
Mass	50 g	±5 %
Cable length	1.5 m	±10 mm
Connector	HD Sub-D connector 15 pin, single channel	
Recommended controller/driver	E-860-series (see p. 1-20)	

*Depending on the control electronics.

**Depending on the drive electronics. 1 nm with E-861.