

P-281 • P-282

Modular XY and XYZ Piezo Flexure Nanopositioning Stages

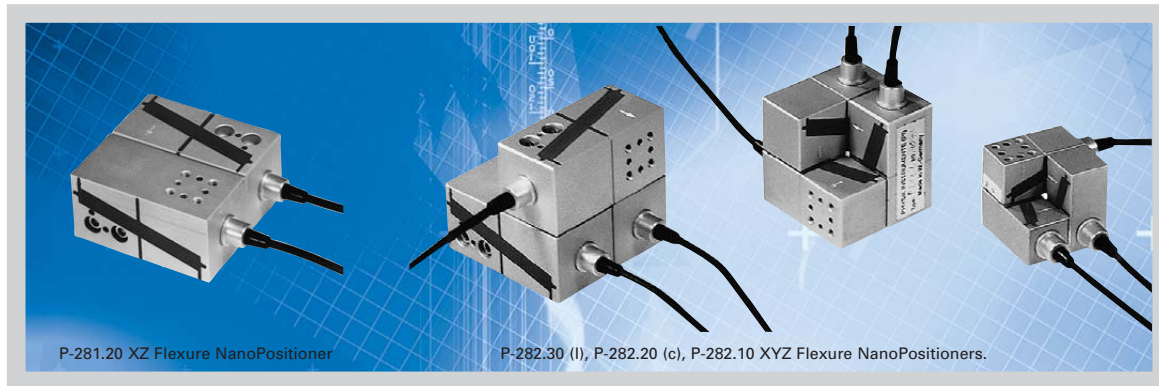

- Cost-Effective XZ (XY) & XYZ Positioning
- Travel Ranges to 100 x 100 x 100 μm

P-281 and P-282 two-axis and three-axis piezo-driven, flexure-guided stages are based on combinations of P-280 stages sold together with assembly hardware (see page 2-30 for specifications and drawing below for assembly). P-281 and P-282 multi-axis stages are available in three different sizes, with travel ranges of 30, 50 and 100 μm .

P-282 XYZ stages are easily assembled by bolting the bottom stage (X) down first and attaching the second (Y) and third (Z) stages successively. P-281 stages can be mounted as XZ and XY combinations.

Notes

See the “Piezo Drivers & Nanopositioning Controllers” section, p. 6-8 *ff.* for our comprehensive line of low-noise control electronics.

See the “Selection Guide” on p. 2-14 *ff.* for comparison with other nanopositioning systems.

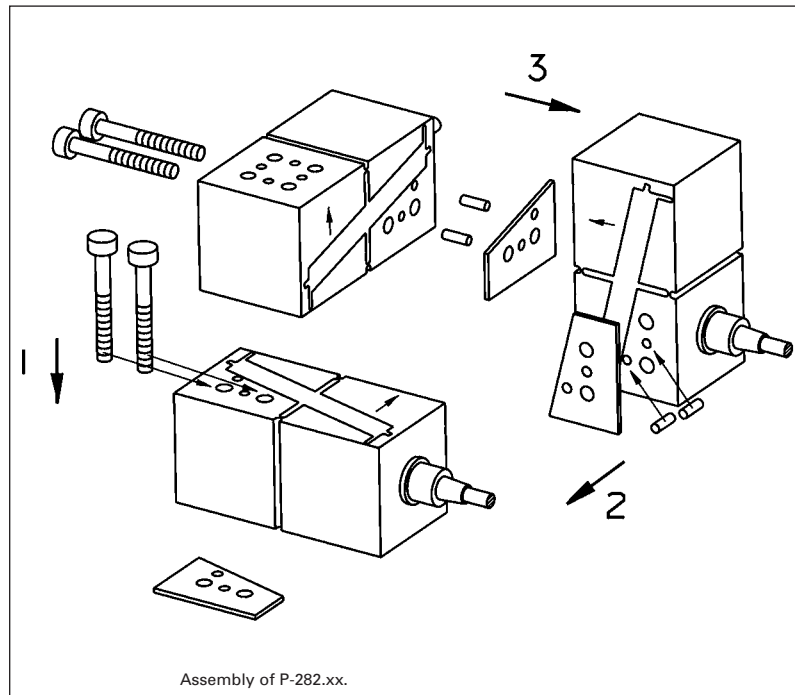

Assembly of P-282.xx.

Technical Data

Models	P-281.10	P-281.20	P-281.30	P-282.10	P-282.20	P-282.30
Axes	X,Z (X,Y)	X,Z (X,Y)	X,Z (X,Y)	X,Y,Z	X,Y,Z	X,Y,Z
Displacement	30 x 30 μm	50 x 50 μm	100 x 100 μm	30 x 30 x 30 μm	50 x 50 x 50 μm	100 x 100 x 100 μm
Consists of	2 x P-280.10	2 x P-280.20	2 x P-280.30	3 x P-280.10	3 x P-280.20	3 x P-280.30
Cable Position*	A + C	A + C	A + C	A + B + C	A + B + C	A + B + C

* See P-280 dimensional drawing on page 2-30.

Piezo Actuators

Nanopositioning & Scanning Systems

Active Optics / Steering Mirrors

Tutorial: Piezo-electrics in Positioning

Capacitive Position Sensors

Piezo Drivers & Nanopositioning Controllers

Hexapods / Micropositioning

Photonics Alignment Solutions

Motion Controllers

Ceramic Linear Motors & Stages

Index