

P-620.Z · P-621.Z · P-622.Z

PIHera® Vertical Piezo Nanopositioning Stages with Direct Metrology



- Z-Travel to 400 μm
- Low Profile
- Resolution <1 nm
- Frictionless Precision Flexure Guiding System
- PICMA® High-Performance Piezo Drives
- Direct Metrology with Capacitive Sensors for Highest Precision
- 0.02 % Position Accuracy
- X, XY, Z, XYZ Versions
- Vacuum-Compatible Versions

P-620.ZCD – P-622.ZCD PIHera® systems are novel piezo nano-Z-axis stages featuring travel ranges from 65 to 400 μm. Despite the increased travel ranges, the units are extremely compact and provide sub-nanometer resolution. The long travel range is achieved with a newly designed, friction-

free and extremely stiff flexure system, which also offers rapid response and excellent guiding accuracy.

Superior Accuracy Through Direct-Motion Metrology with Capacitive Sensors

The capacitive-sensor-equipped versions provide motion linearity to 0.02% with effective resolution in the sub-nanometer range. PI capacitive sensors are absolute-measuring, direct-metrology devices that boast very high bandwidth and exhibit no periodic errors.

Unlike conventional sensors, capacitive sensors measure the actual distance between

the fixed frame and the moving part of the stage. They detect errors contributed by all components in the drive train—from the actuator through the flexures to the platform. This results in higher motion linearity, long-term stability, phase fidelity, and—because external disturbances are seen by the sensor immediately—a stiffer, faster-responding servo-loop. See p. 2-4 *ff.* and p. 5-2 *ff.* for more information.

Nanometer Precision in Milliseconds

One of the advantages of PIHera® stages over motor-driven positioning stages is the rapid response to input changes and fast and precise settling behavior. Furthermore our new digital control electronics with DDL (Dynamic Digital Linearization) can be used to increase linearity and effective bandwidth in scanning applications by up to 1000-fold (see p. 6-16).

Working Principle / Reliability

PIHera® stages are equipped with the award winning PICMA® piezo drives, integrated into a sophisticated flexure guiding system. The flexures are FEA-modeled for zero-friction and exceptional guiding precision. The ceramic-encapsulated PICMA® drives are more robust than conventional piezo actuators, featuring superior lifetime and performance in both dynamic and static applications. Because guidance, actuators and sensors are all frictionless and maintenance-free, these nanopositioning systems achieve outstanding levels of reliability.

Single & Multi-Axis Versions

See page 2-40 and page 2-54 for X and XY versions. XZ and XYZ combinations can be assembled without adapters.

Ordering Information

P-620.ZCD
PIHera® Vertical Nanopositioning System, 50 μm, Capacitive Sensors, Sub-D Connector

P-620.ZCL
PIHera® Vertical Nanopositioning System, 50 μm, Capacitive Sensors, LEMO Connectors

P-620.Z0L
PIHera® Vertical Nanopositioning System, 65 μm, Open-Loop, LEMO Connector

P-621.ZCD
PIHera® Vertical Nanopositioning System, 100 μm, Capacitive Sensors, Sub-D Connector

P-621.ZCL
PIHera® Vertical Nanopositioning System, 100 μm, Capacitive Sensors, LEMO Connectors

P-621.Z0L
PIHera® Vertical Nanopositioning System, 140 μm, Open-Loop, LEMO Connector

P-622.ZCD
PIHera® Vertical Nanopositioning System, 250 μm, Capacitive Sensors, Sub-D Connector

P-622.ZCL
PIHera® Vertical Nanopositioning System, 250 μm, Capacitive Sensors, LEMO Connectors

P-622.Z0L
PIHera® Vertical Nanopositioning System, 400 μm, Open-Loop, LEMO Connector

Vacuum versions
to 10⁻⁹ hP are available as part numbers P-62x.ZUD

X & XY Versions:
See separate datasheets.

Custom sizes & specifications available!

Notes

See the “Selection Guide” on p. 2-14 *ff.* for comparison with other nanopositioning systems.

Application Examples

- (Dynamic) interferometry
- Microscopy
- Nanopositioning
- Biotechnology
- Quality assurance
- Semiconductor technology

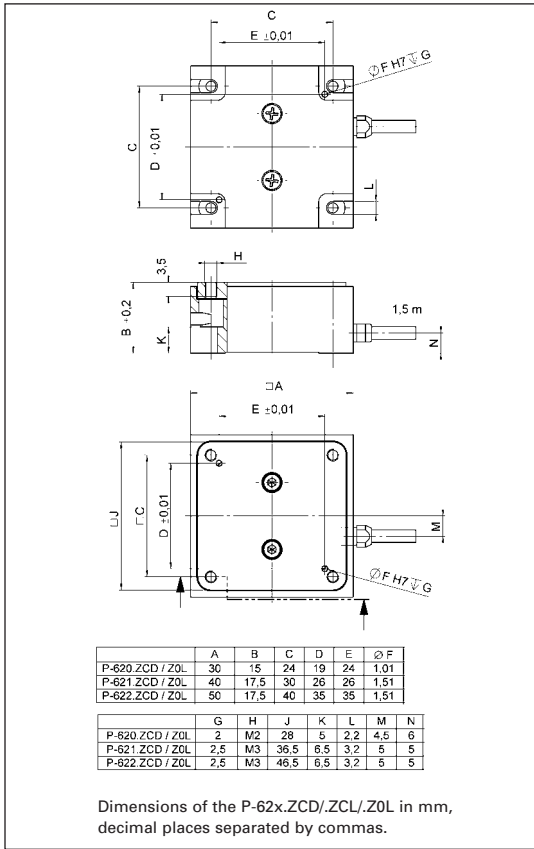

Piezo Actuators

Nanopositioning & Scanning Systems

Active Optics / Steering Mirrors

Tutorial: Piezo-electrics in Positioning

Capacitive Position Sensors

Piezo Drivers & Nanopositioning Controllers

Hexapods / Micropositioning

Photonics Alignment Solutions

Motion Controllers

Ceramic Linear Motors & Stages

Index

Technical Data

Models	P-620.ZCD	P-621.ZCD	P-622.ZCD	P-62x.ZCL	P-62x.ZOL	Units	Notes see p. 2-84
Active axes	Z	Z	Z	Z	Z		
Open-loop travel -20 to 120 V	65	140	400	see P-62x.ZCD	see P-62x.ZCD	µm	A2
Closed-loop travel	50	100	250	see P-62x.ZCD	-	µm	A5
Integrated feedback sensor	capacitive	capacitive	capacitive	see P-62x.ZCD	-		B
* Closed-loop / open-loop resolution	0.2 / 0.1	0.3 / 0.2	1 / 0.5	see P-62x.ZCD	- / see P-62x.ZCD	nm	C1
Closed-loop linearity (typ.)	0.02	0.02	0.02	see P-62x.ZCD	-	%	
Stiffness	0.5	0.6	0.24	see P-62x.ZCD	see P-62x.ZCD	N/µm	D1
Push / pull force capacity (in X)	10/5	10/8	10/8	see P-62x.ZCD	see P-62x.ZCD	N	D3
Max. load	10	10	10	see P-62x.ZCD	see P-62x.ZCD	N	D4
Lateral force limit	10	10	10	see P-62x.ZCD	see P-62x.ZCD	N	D5
Tilt (θ _x ,θ _y) (typ.)	<80	<100	<200	see P-62x.ZCD	see P-62x.ZCD	µrad	E1
Electrical capacitance	1.5	3.0	6.0	see P-62x.ZCD	see P-62x.ZCD	µF ±20%	F1
Dynamic operating current coefficient (DOCC)	3.75	3.75	3.0	see P-62x.ZCD	see P-62x.ZCD	µA/(Hz x µm)	F2
Unloaded resonant frequency	1.000	790	350	see P-62x.ZCD	see P-62x.ZCD	Hz ±20%	F2
Resonant frequency @ 30 g load	690	500	270	see P-62x.ZCD	see P-62x.ZCD	Hz ±20%	G2
Operating temperature range	-40 to 120	-40 to 120	-40 to 120	see P-62x.ZCD	-40 - 150	°C	H2
Voltage Connection	D	D	D	VL	VL		J1
Sensor Connection	D	D	D	2 x C	-		J2
Weight (with cables)		170				g ±5%	L
Body material	Al	Al	Al	see P-62x.ZCD	see P-62x.ZCD		
Recommended amplifier/controller (codes explained p. 2-17)	F, M, L, H	F, M, L, H	F, M, L, H	F, M, L, H	C, G		

* For calibration information see p. 2-8. Resolution of PI piezo nanopositioners is not limited by friction or stiction. Noise equivalent motion with E-710 controller.