

# P-734 XY Piezo Scanner

## High-Dynamics System with Minimum Runout & Clear Aperture



P-734 low-bow flexure nanopositioning stage with ultra-precise trajectory control

- **Ultra-Precision Trajectory Control, Ideal for Surface Analysis and Scanning Microscopy**
- **Parallel-Kinematics / Metrology for Enhanced Responsiveness / Multi-Axis Precision**
- **Travel Range 100 x 100  $\mu\text{m}$ , Clear Aperture 56 x 56 mm**
- **Capacitive Sensors for Resolution <0,4 nm**
- **Outstanding Lifetime Due to PICMA® Piezo Actuators**

P-734 high-dynamics, XY piezo nanopositioning stages feature linear travel ranges to 100 x 100  $\mu\text{m}$  with sub-nanometer resolution and maximum flatness of motion.

### Flatness in the Low Nanometer Range

P-734 open-frame XY nanopositioning and scanning stages are ideal for nanometrology

### Application Examples

- Scanning microscopy
- Metrology / interferometry
- Semiconductor testing
- Mask/wafer positioning
- Image processing / stabilization
- Biotechnology
- Micromanipulation
- Nanopositioning

tasks that require extreme flatness of scanning. These stages feature an ultra-precise, flexure guiding system which confines motion to the XY plane and reduces runout in Z to a few nanometers or less. This unsurpassed trajectory precision is fundamental for highest-precision surface metrology applications. These stages provide a positioning and scanning range of 100 x 100  $\mu\text{m}$  with accuracy and resolution in the nanometer and sub-nanometer range.

### Excellent Guiding Accuracy

Flexures optimized with Finite Element Analysis (FEA) are used to guide the stage. FEA techniques are used to give the design the highest possible stiffness in, and perpendicular to, the direction of motion, and to minimize linear and angular runout. Flexures allow extremely high-precision motion, no matter how minute, as they

are completely free of play and friction.

### Higher Precision in Periodic Motion

The highest dynamic accuracy in scanning applications is made possible by the DDL algorithm, which is available in PI's modern digital controllers. DDL eliminates tracking errors, improving dynamic linearity and usable bandwidth by up to three orders of magnitude!

### Direct Position Measurement with Sub-Nanometer Accuracy

PI's proprietary capacitive sensors measure position directly and without physical contact. They are free of friction and hysteresis, a fact which, in combination with the positioning resolution of well under 1 nm, makes it possible to achieve very high levels of linearity. A further advantage of direct metrology with capacitive sensors is the high phase fidelity and the high bandwidth of up to 10 kHz.

### Parallel Kinematics and Metrology with Capacitive Sensors for High Trajectory Fidelity

In a parallel kinematics multi-axis system, all actuators act directly on one moving platform. This means that all axes move the same minimized mass and can be designed with

### Ordering Information

**P-734.2CD**  
High-Precision XY Nanopositioning System with Minimum Runout, 100 x 100  $\mu\text{m}$ , Capacitive Sensors, Parallel Metrology, Sub-D Connector

**P-734.2CL**  
High-Precision XY Nanopositioning System with Minimum Runout, 100 x 100  $\mu\text{m}$ , Capacitive Sensors, Parallel Metrology, LEMO Connector

identical dynamic properties. Systems with parallel kinematics and metrology have additional advantages over serially stacked or nested systems, including more-compact construction and no cumulative error from the different axes. Parallel kinematics systems can be operated with up to six degrees of freedom with low inertia and excellent dynamic performance. Multi-axis nanopositioning systems equipped with both parallel kinematics and parallel, direct metrology are able to measure platform position in all degrees of freedom against one common fixed reference. In such systems, undesirable motion from one actuator in the direction of another (cross talk) is detected immediately and actively compensated by the servo-loops. This Active Trajectory Control Concept can keep deviation from a trajectory to under a few nanometers, even in dynamic operation.

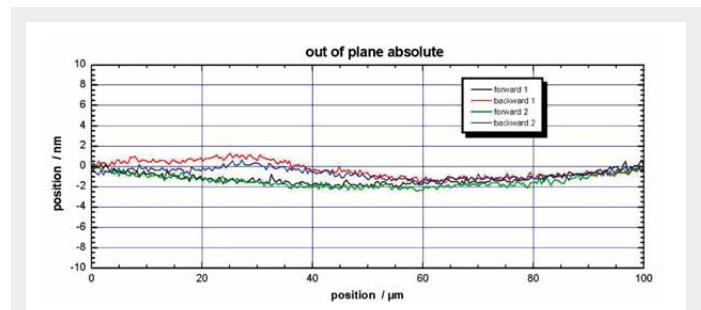

Typical flatness of P-734 motion is in the low nanometer range

### Ceramic Insulated Piezo Actuators Provide Long Lifetime

Highest possible reliability is assured by the use of award-winning PICMA® multilayer piezo actuators. PICMA® actuators are the only actuators on the market with ceramic-only insulation, which makes them resistant to ambient humidity and leakage-current failures. They are thus far superior to conventional actuators in reliability and lifetime.

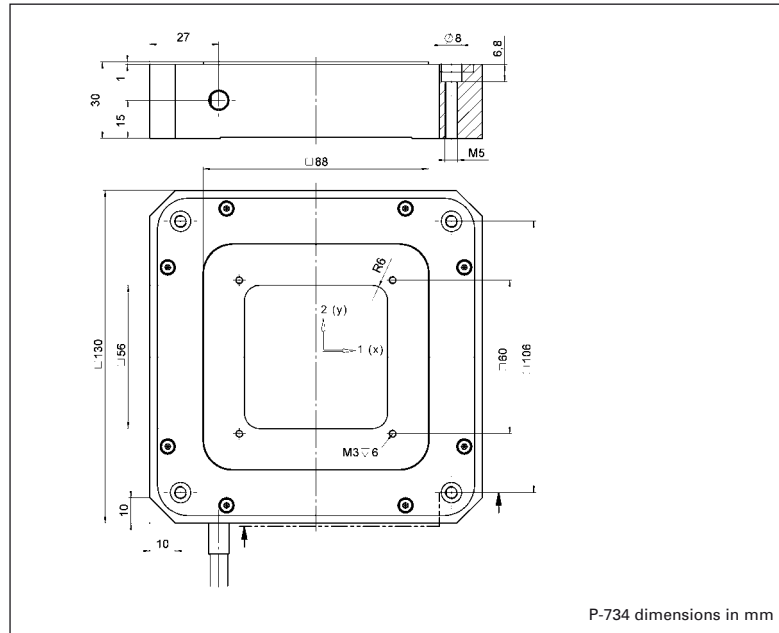

### Technical Data

Model	P-734.2CL	P-734.2CD	Units	Tolerance
Active axes	X, Y	X, Y		
<b>Motion and positioning</b>				
Integrated sensor	Capacitive	Capacitive		
Open-loop travel, -20 to +120 V	110 x 110	110 x 110	μm	min. (+20%/-0%)
Closed-loop travel	100 x 100	100 x 100	μm	
Open-loop resolution	0.2	0.2	nm	typ.
Closed-loop resolution	0.3	0.3	nm	typ.
Linearity	0.03	0.03	%	typ.
Repeatability	<2.5	<2.5	nm	typ.
Pitch	<3	<3	μrad	typ.
Yaw	<10	<10	μrad	typ.
Flatness	<5	<5	nm	typ.
<b>Mechanical properties</b>				
Stiffness	3	3	N/μm	±20%
Unloaded resonant frequency	500	500	Hz	±20%
Resonant frequency @ 200 g	350	350	Hz	±20%
Resonant frequency @ 500 g	250	250	Hz	±20%
Push/pull force capacity in motion direction	300 / 100	300 / 100	N	Max.
Load capacity	20	20	N	Max.
<b>Drive properties</b>				
Ceramic type	PICMA® P-885	PICMA® P-885		
Electrical Capacitance	6.2	6.2	μF	±20%
Dynamic operating current coefficient	7.8	7.8	μA/(Hz • μm)	±20%
<b>Miscellaneous</b>				
Operating temperature range	-20 to 80	-20 to 80	°C	
Material	Aluminum	Aluminum		
Mass (with cables)	1.04	1.04	kg	±5%
Cable length	1.5	1.5	m	±10 mm
Sensor connection	2x LEMO	Sub-D Special		
Voltage connection	4x LEMO	Sub-D Special		

Dynamic Operating Current Coefficient in μA per Hz and μm. Example: Sinusoidal scan of 10 μm at 10 Hz requires approximately 7.8 mA drive current.

Recommended controller / amplifier  
 P-734.2CL (p. 2-64): E-500 modular piezo controller system (p. 2-142) with amplifier module E-503 (three channels) (p. 2-146) or E-505 (1 per axis, high performance) (p. 2-147) and E-509 controller (p. 2-152)  
 P-734.2CD (p. 2-64):  
 Multi-channel digital controllers: E-710/E-725 bench-top (p. 2-128, p. 2-126), E-712 modular (p. 2-140), E-761 PCI board (p. 2-130)

### Linear Actuators & Motors

### Nanopositioning / Piezoelectrics

### Piezo Flexure Stages / High-Speed Scanning Systems

Linear

Vertical & Tip/Tilt

2- and 3-Axis

6-Axis

Fast Steering Mirrors / Active Optics

Piezo Drivers / Servo Controllers

Single-Channel

Multi-Channel

Modular

Accessories

Piezoelectrics in Positioning

### Nanometrology

### Micropositioning

### Index