

# P-772.0L

## Ultra-Compact Open-Loop PZT Nanopositioning Stage



P-772.0L piezo nanopositioning stage with dip-switch for size comparison.

- Small Flexure-Guided Stage
- 50 Picometer Resolution
- 10  $\mu\text{m}$  Travel
- Ultra-Fast Response (1.7 kHz Resonant Frequency)
- Closed-Loop Version Available

P-772.0L open-loop NanoAutomation® stages are very compact flexure-guided nanopositioners. They provide a positioning and scanning range of up to 10  $\mu\text{m}$ , sub-nanometer resolution and ultra-fast response. P-772 stages are designed for applications with small loads.

### Ordering Information

**P-772.0L**  
Ultra-Compact Open-Loop  
PZT Stage, 10  $\mu\text{m}$

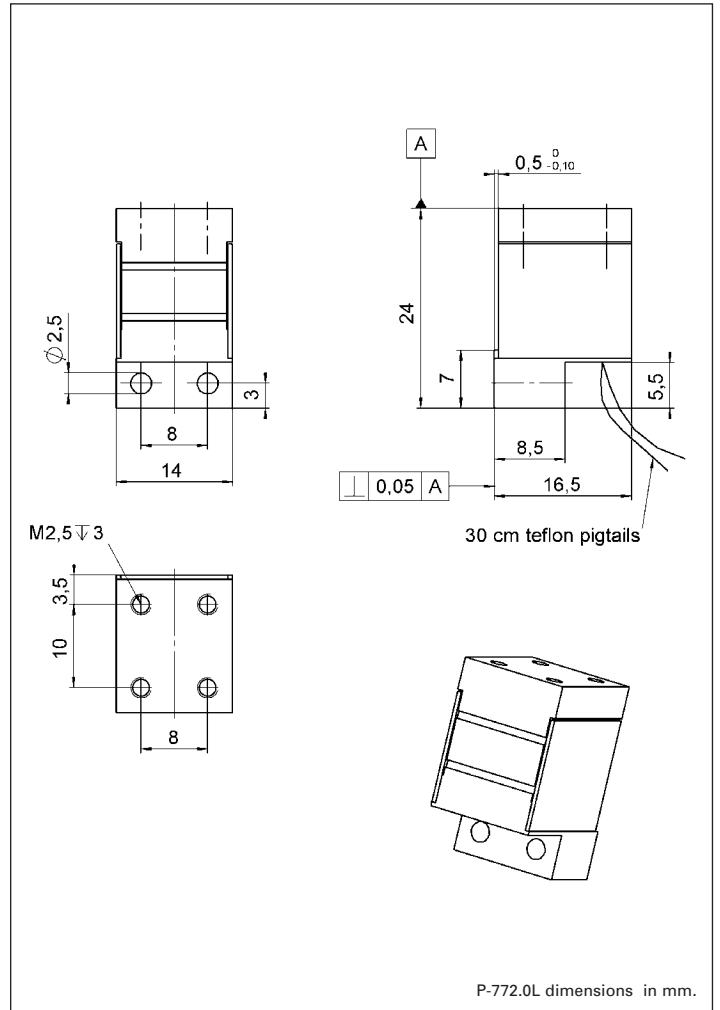

P-772.0L dimensions in mm.

A closed-loop version is available as the P-772.1CD (see p. 2-24).

### Application Examples

- Laser tuning
- Fiber optics
- Metrology
- Nanopositioning
- Scanning microscopy
- Scanning interferometry
- Biotechnology
- Micromanipulation, etc.

### Technical Data

Models	P-772.0L	Units	Notes see page 2-84
Active axes	X		
Min. open-loop travel, -20 to 120 V	10	$\mu\text{m} \pm 20\%$	A2
** Open-loop resolution	0.05	nm	C1
Stiffness	7	$\text{N}/\mu\text{m} \pm 20\%$	D1
Push/pull force capacity (in operating direction)	50 / 5	N	D3
Max. ( $\pm$ ) normal load	0.5	kg	D4
Lateral force limit	10	N	D5
Electrical capacitance	0.9	$\mu\text{F} \pm 20\%$	F1
* Dynamic operating current coefficient (DOCC)	9	$\mu\text{A}/(\text{Hz} \times \mu\text{m})$	F2
Unloaded resonant frequency	1700	$\text{Hz} \pm 20\%$	G2
Operating temperature range	-20 to 80	$^{\circ}\text{C}$	H2
Voltage connection	Pigtails, 300 mm		
Weight (w/o cables)	170	$\text{g} \pm 5\%$	
Body material	N-S		L

Recommended Amplifier/Controller  
(codes explained see link 6-46)

A, C, G

\* Dynamic Operating Current Coefficient in  $\mu\text{A}$  per Hz and  $\mu\text{m}$ .

\*\* For calibration information see p. 2-8. Resolution of PI piezo nanopositioners is not limited by friction or stiction. The value given is noise equivalent motion with E-503 amplifier.