

P-810 • P-830 Piezo Actuators For Light and Medium Loads



- Outstanding Lifetime Due to PICMA® Piezo Ceramics
- Travel Range to 60 μm
- Pushing Forces to 1000 N
- Pulling Forces to 5 N
- Sub-Millisecond Response
- Sub-Nanometer Resolution

The P-810 and P-830 series translators are high-resolution linear actuators for static and dynamic applications. They provide sub-millisecond response and sub-nanometer resolution.

Application Examples

- Static and dynamic precision positioning
- Fiber positioning
- Laser tuning
- Patch-Clamp
- Nanotechnology

Design

These actuators consist of a highly reliable monolithic multilayer piezoceramic stack protected by a stainless steel case. PI offers a variety of pre-loaded translators for applications involving higher tensile loads (see the "Selection Guide" on p. 1-62).

Ceramic Insulated Piezo Actuators Provide Long Lifetime

Highest possible reliability is assured by the use of award-winning PICMA® multilayer piezo actuators. PICMA® actuators are the only actuators on

the market with ceramic-only insulation, which makes them resistant to ambient humidity and leakage-current failures. They are thus far superior to conventional actuators in reliability and lifetime.

Mounting

Attachment is realized via the ferromagnetic end surfaces, with epoxy or magnets. Read details in Mounting and Handling Guidelines (p. 1-67). For extensions, adapter cables and connectors, see "Accessories" (p. 2-168 ff).

Piezo Drivers, Controllers & Amplifiers

High-resolution amplifiers and servo-control electronics, both digital and analog, are described in the "Piezo Drivers / Servo Controllers" section (see p. 2-99 ff).

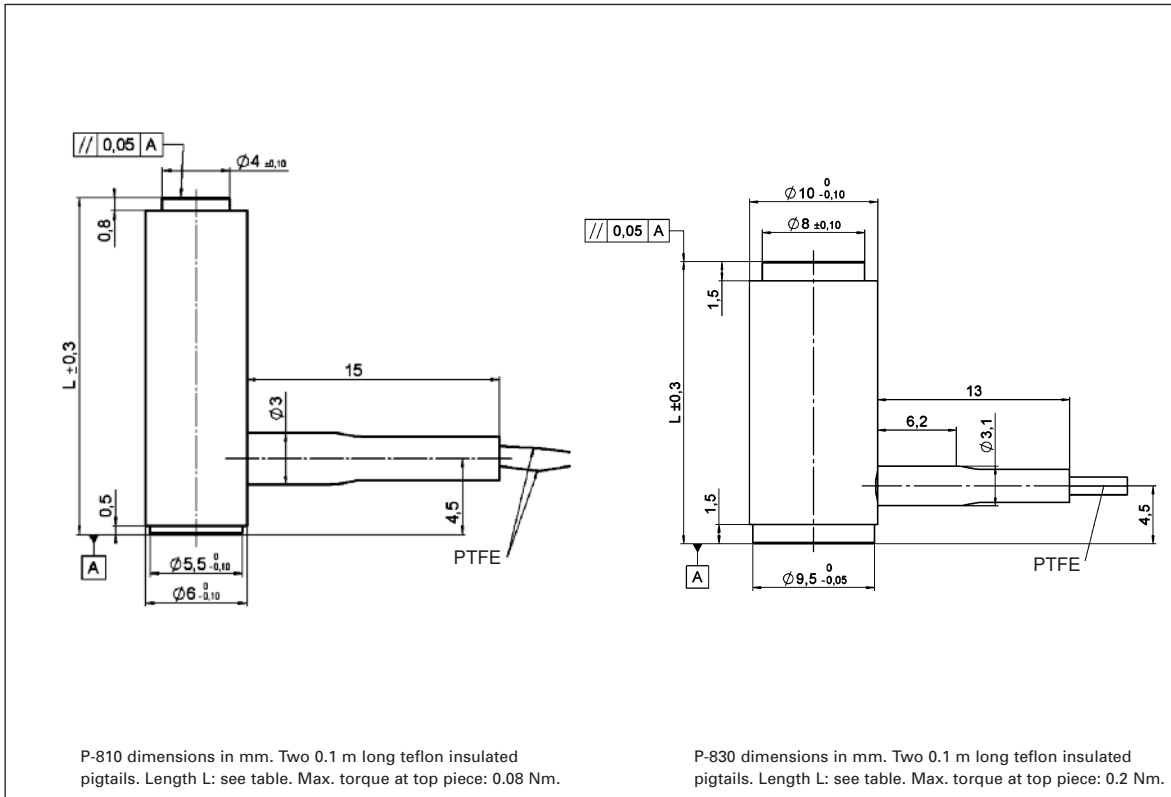
Linear Actuators & Motors

PiezoWalk® Motors / Actuators

PLLine® Ultrasonic Motors

DC-Servo & Stepper Actuators

Piezo Actuators & Components
Guided / Preloaded Actuators

Unpackaged Stack Actuators

Patches/Benders/Tubes/Shear..

Nanopositioning / Piezoelectrics

Nanometrology

Micropositioning

Index

Technical Data and Product Order Numbers

Order number	Travel range for 0 to 100 V [μm] ±20 %	*Resolution [nm]	**Static large-signal stiffness [N/μm] ±20 %	Push- / pull force capacity [N]	Electrical capacitance [μF] ±20 %	Dynamic operating current coefficient [μA / (Hz · μm)]	Resonant frequency (unloaded) [kHz] ±20 %	Mass [g] ±5 %	Length L [mm] ±0.3
P-810.10	15	0.15	14	50 / 1	0.3	3.0	22	4	20
P-810.20	30	0.3	7	50 / 1	0.7	3.0	15	6	38
P-810.30	45	0.45	4	50 / 1	1.0	3.0	12	8	56
P-830.10	15	0.15	57	1000 / 5	1.5	12.5	23	10	22
P-830.20	30	0.3	27	1000 / 5	3.0	12.5	14	16	40
P-830.30	45	0.45	19	1000 / 5	4.5	12.5	10	21	58
P-830.40	60	0.6	15	1000 / 5	6.0	12.5	8.5	27	76

*The resolution of piezo actuators is not limited by stiction or friction. Value given is noise equivalent motion with E-503 amplifier (p. 2-144)

**Dynamic small-signal stiffness is ~ 30 % higher. Operating temperature range: -20 to 120° C. Case: non-magnetic steel; end pieces: stainless steel. Recommended preload for dynamic operation: 10–20 MPa.

Recommended amplifiers / controllers

One channel: E-831 amplifier (p. 2-164), E-610 amplifier / controller (p. 2-110)

Multi-channel: E-663 amplifier (p. 2-136)