

P-007 - P-056

PICA™-Stack Piezoceramic Actuators—Versatile Piezoelectric Power (HVPZT)

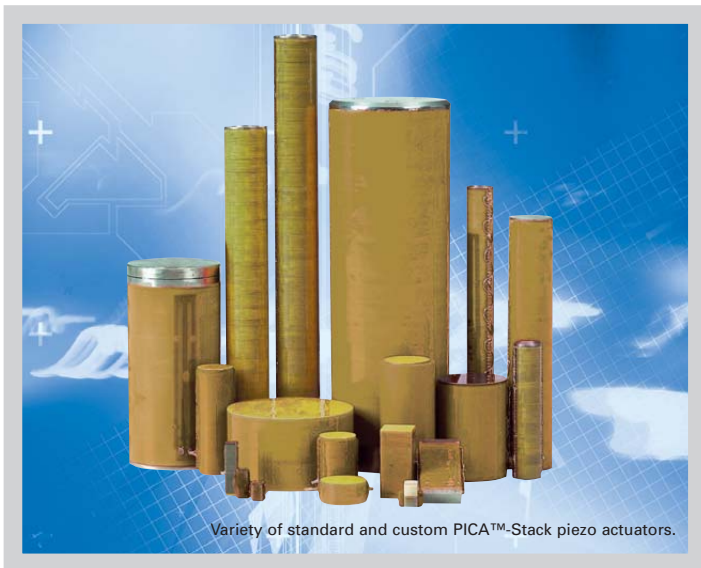

Variety of standard and custom PICA™-Stack piezo actuators.

- High Load Capacity to 100 kN
- High Force Generation to 80 kN
- Large Cross Sections to 56 mm Diameter
- Variety of Shapes
- Extreme Reliability >10⁹ Cycles
- Proven and Flexible Design
- Sub-Nanometer-Resolution / Sub-Millisecond-Settling-Time
- Vacuum-Compatible Versions

PICA™-Stack piezo ceramic actuators are offered in a large variety of standard shapes and sizes with additional custom designs to suit any application.

Ultra-High Reliability, High Displacement, Low Power Requirements

PICA™-Stack actuators are specifically designed for high-

duty-cycle applications. With our extensive applications knowledge, gained over several decades, we know how to build performance that does not come at the price of reliability. All materials used are specifically matched for robustness and lifetime. Endurance tests on PICA™ actuators prove consistent performance, even after billions (1,000,000,000) of cycles. The combination of high displacement and low electrical capacitance provides for excellent dynamic behavior with reduced driving power requirements.

Flexibility: PI Ceramic's Strength

All manufacturing processes at PI Ceramic are set up for flexibility. Should our standard actuators not fit your applica-

tion, let us provide you with a custom design. Our engineers will work with you to find the optimum solution at a very attractive price, even for small quantities. Some of our custom capabilities are listed below:

- Custom Materials
- Custom Voltage Ranges
- Custom Geometries (Circular, Rectangular, Triangular, Layer Thickness ...)
- Custom Displacement
- Custom Load / Force Ranges
- Custom Flat or Spherical Endplates (Alumina, Glass, Sapphire, ...)
- Extra-Tight Length Tolerances
- Integrated Piezoelectric Sensor Discs
- Special High / Low Temperature Versions
- Vacuum Compatible Versions

Short Leadtime, Standard & Custom Designs

Because all piezoelectric materials used in PICA™ actuators are manufactured at PI Ceramic, leadtimes are short and quality is outstanding. All standard and custom PICA™-Stack actuators are delivered with performance test sheets.

Amplifiers, Drivers & Controllers

PI offers a wide range of control electronics for piezo actuators, from low-power drivers to multi-channel, closed-loop, digital controllers. Of course, PI also designs custom amplifiers and controllers.

Notes

PICA™-Stack actuators are delivered with metal endcaps for improved robustness and reliability. Adherence to the

mounting and handling guidelines (see p. 1-48) will help you obtain maximum performance and lifetime from your piezo actuators.

See page 1-40 ff. for preloaded actuators.



Custom PICA™-Stack actuator with 350 μm displacement.

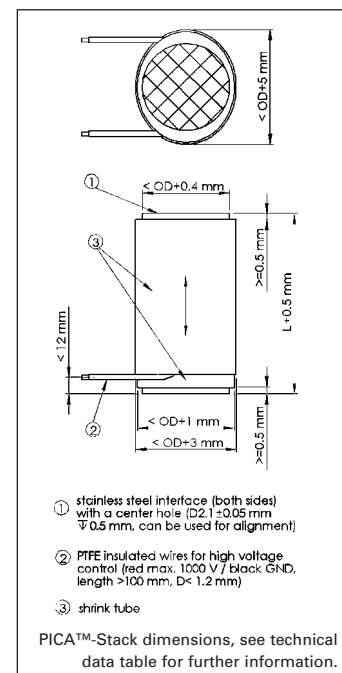

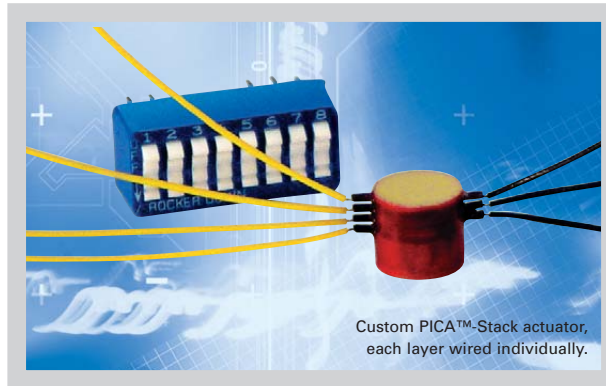

Technical Data / Product Order Numbers

Order number	Displacement [μm] -10/+20%	Diameter D [mm]	Length L [mm] ±0.5	Blocking force [N]	Stiffness [N/μm]	Capacitance [nF] ±20%	Resonant frequency [kHz]
P-007.00	5	7	8	650	130	11	126
P-007.10	15	7	17	850	59	33	59
P-007.20	30	7	29	1000	35	64	36
P-007.40	60	7	54	1150	19	130	20
P-010.00	5	10	8	1400	270	21	126
P-010.10	15	10	17	1800	120	64	59
P-010.20	30	10	30	2100	71	130	35
P-010.40	60	10	56	2200	38	260	20
P-010.80	120	10	107	2400	20	510	10
P-016.10	15	16	17	4600	320	180	59
P-016.20	30	16	29	5500	190	340	36
P-016.40	60	16	54	6000	100	680	20
P-016.80	120	16	101	6500	54	1300	11
P-016.90	180	16	150	6500	36	2000	7
P-025.10	15	25	18	11000	740	400	56
P-025.20	30	25	30	13000	440	820	35
P-025.40	60	25	53	15000	250	1700	21
P-025.80	120	25	101	16000	130	3400	11
P-025.90	180	25	149	16000	89	5100	7
P-025.150	250	25	204	16000	65	7100	5
P-025.200	300	25	244	16000	54	8500	5
P-035.10	15	35	20	20000	1300	700	51
P-035.20	30	35	32	24000	810	1600	33
P-035.40	60	35	57	28000	460	3300	19
P-035.80	120	35	104	30000	250	6700	11
P-035.90	180	35	153	31000	170	10000	7
P-045.20	30	45	33	39000	1300	2800	32
P-045.40	60	45	58	44000	740	5700	19
P-045.80	120	45	105	49000	410	11000	10
P-045.90	180	45	154	50000	280	17000	7
P-050.20	30	50	33	48000	1600	3400	32
P-050.40	60	50	58	55000	910	7000	19
P-050.80	120	50	105	60000	500	14000	10
P-050.90	180	50	154	61000	340	22000	7
P-056.20	30	56	33	60000	2000	4300	32
P-056.40	60	56	58	66000	1100	8900	19
P-056.80	120	56	105	76000	630	18000	10
P-056.90	180	56	154	78000	430	27000	7

Recommended preload for dynamic operation
15 to 30 MPa

Unloaded (longitudinal) resonant frequency measured at 1 V_{pp}; capacitance at 1 V_{pp}, 1 kHz; blocking force at 1000 V.

Standard PZT ceramic type:
PIC 151

Operating voltage range:
0 to 1000 V

Operating temperature range:
-20 to +85 °C

Standard mechanical interface (top & bottom): steel plates, 0.5 - 2 mm thick (depends on model)

Standard electrical interface: two PTFE-insulated wires, pigtail length 100 mm

Available options: integrated piezo force sensor or strain gauge sensors, non magnetic, vacuum compatible, etc.

Other specifications on request.

Piezo Actuators

Nanopositioning & Scanning Systems

Active Optics / Steering Mirrors

Tutorial: Piezo-electrics in Positioning

Capacitive Position Sensors

Piezo Drivers & Nanopositioning Controllers

Hexapods / Micropositioning

Photonics Alignment Solutions

Motion Controllers

Ceramic Linear Motors & Stages

Index