

Precision Rotation Stage

High Run-Out Accuracy



L-611

- Unlimited travel range
- Very high resolution
- Maximum velocity 200°/s
- DC, BLDC, and stepper motors
- Direction-sensing reference switch
- Vacuum-compatible variants available

Reference-class rotation stage

High-precision positioning due to low-play preloaded worm gear. Preloaded pivot bearings for high run-out accuracy. Clear aperture with 35 mm Ø. Unlimited travel range in both directions of rotation. Noncontact reference switch. Compact multi-axis positioning systems possible with L-511 linear stages and L-310 Z stages. Vacuum-compatible product variants on request.

Versions

- Low-vibration stepper motor
- DC motor with ActiveDrive
- DC servo motor
- Brushless DC motor
- Additional high-resolution optical angle measuring system, direct measuring

Option: Measurement of the run-out accuracy and positioning accuracy

Individual measurement logs available on request for wobble, axial, and radial creep. Please specify when ordering.

Application fields

Medical industry. Sample inspection. Precision microassembly. Measuring technology. Photonics. Vacuum.

Motion	Unit	Tolerance	L-611.90AD	L-611.94AD	L-611.993232	L-611.993261	L-611.995232	L-611.9ASD	L-611.90SD
Active axes			ØZ	ØZ	ØZ	ØZ	ØZ	ØZ	ØZ
Rotation range in ØZ	°		360	360	360	360	360	360	360
Maximum angular velocity in ØZ, unloaded	°/s		200	200	200	200	200	50	50
Radial error in X	µm	Typ.	±2.5	±2.5	±2.5	±2.5	±2.5	±2.5	±2.5
Axial error	µm	Typ.	±1	±1	±1	±1	±1	±1	±1
Tilt error around X (wobble)	µrad	Typ.	±15	±15	±15	±15	±15	±15	±15

Positioning	Unit	Tolerance	L-611.90AD	L-611.94AD	L-611.993232	L-611.993261	L-611.995232	L-611.9ASD	L-611.90SD
Minimum incremental motion in θZ	μrad	Typ.	35	17.45	35	3.5	35	0.87	20
Unidirectional repeatability in θZ	μrad	Typ.	± 17.5	± 8.725	± 17.5	± 1.75	± 17.5	± 0.435	± 10
Bidirectional repeatability in θZ	μrad	Typ.	350	34.9	350	7	350	7	350
Reference switch			Hall effect, N/C contact, 5 V, TTL	Hall effect, N/C contact, 5 V, TTL	Hall effect, N/C contact, 5 V, TTL	Hall effect, N/C contact, 5 V, NPN	Hall effect, N/C contact, 5 V, TTL	Hall effect, N/C contact, 5 V, NPN	Hall effect, N/C contact, 5 V, NPN
Reference switch repeatability, rotational	μrad		2	2	2	2	2	2	2
Integrated sensor			Incremental rotary encoder	Incremental angle-measuring system	Incremental rotary encoder	Incremental angle-measuring system	Incremental rotary encoder	Incremental angle-measuring system	—
Sensor signal			A/B quadrature, RS-422	A/B quadrature, RS-422	A/B quadrature, RS-422	Sin/cos, 1 V peak-to-peak	A/B quadrature, RS-422	Sin/cos, 1 V peak-to-peak	—
Sensor signal periods/U			—	9000	—	9000	—	9000	—
Sensor resolution	Cts./rev.		20000	—	20000	—	20000	—	—

Drive properties	Unit		L-611.90AD	L-611.94AD	L-611.993232	L-611.993261	L-611.995232	L-611.9ASD	L-611.90SD
Drive type			DC motor with ActiveDrive	DC motor with ActiveDrive	DC motor	DC motor	Brushless DC motor	2-phase stepper motor	2-phase stepper motor
Operating voltage	V		24	24	24	24	24	24	24
Nominal current, RMS	A	Typ.	—	—	3.3	3.3	2.42	1.2	1.2
Maximum power consumption	W		40	40	90	90	85	10	10
Motor resolution	Full steps/rev.		—	—	—	—	—	200	200
Torque constant	N·m/A	Typ.	—	—	—	—	0.031	—	—
Resistance phase-phase	Ω	Typ.	—	—	5.84	5.84	0.4	3.3	3.3
Inductance phase-phase	mH		—	—	0.56	0.56	0.32	2.8	2.8
Back EMF, phase-phase, rotational	V/kRPM	Max.	—	—	—	—	3.3	—	—
Number of pole pairs			—	—	—	—	7	—	—

Mechanical properties	Unit	Tolerance	L-611.90AD	L-611.94AD	L-611.993232	L-611.993261	L-611.995232	L-611.9ASD	L-611.90SD
Permissible push force in X	N	Max.	50	50	50	50	50	50	50
Permissible push force in Y	N	Max.	50	50	50	50	50	50	50
Permissible push force in Z	N	Max.	100	100	100	100	100	100	100
Permissible pull force in X	N	Max.	50	50	50	50	50	50	50
Permissible pull force in Y	N	Max.	50	50	50	50	50	50	50
Permissible pull force in Z	N	Max.	100	100	100	100	100	100	100
Permissible torque in θX	N·m	Max.	40	40	40	40	40	40	40
Permissible torque in θY	N·m	Max.	40	40	40	40	40	40	40
Permissible torque in θZ	N·m	Max.	3	3	3	3	3	3	3
Moment of inertia in θZ , unloaded	kg·mm ²	$\pm 20\%$	770	770	770	770	770	770	770
Moved mass in θZ , unloaded	g		1100	1100	1100	1100	1100	1100	1100
Worm gear reduction			90 : 1	90 : 1	90 : 1	90 : 1	90 : 1	90 : 1	90 : 1
Bearing type			Ball bearings	Ball bearings	Ball bearings	Ball bearings	Ball bearings	Ball bearings	Ball bearings
Overall mass	g		2600	2600	2600	2600	2600	2600	2600
Material			Aluminum, anodized; stainless steel; red bronze	Aluminum, anodized; stainless steel; red bronze	Aluminum, anodized; stainless steel; red bronze	Aluminum, anodized; stainless steel; red bronze	Aluminum, anodized; stainless steel; red bronze	Aluminum, anodized; stainless steel; red bronze	Aluminum, anodized; stainless steel; red bronze

Miscellaneous	Unit	L-611.90AD	L-611.94AD	L-611.993232	L-611.993261	L-611.995232	L-611.9ASD	L-611.90SD
Operating temperature range	°C	5 to 40	5 to 40	5 to 40	5 to 40	5 to 40	5 to 40	5 to 40
Connector		D-sub 15 (m)	D-sub 15 (m)	HD D-sub 26 (m)	HD D-sub 26 (m)	HD D-sub 26 (m)	HD D-sub 26 (m)	HD D-sub 26 (m)
Sensor connector		—	—	—	D-sub 9 (m)	—	D-sub 9 (m)	—
Connector for supply voltage		M8 4-pole (m)	M8 4-pole (m)	—	—	—	—	—
Recommended controllers/ drivers		C-863.12 C-885 with C-863.20C885 C-884	C-863.12 C-885 with C-863.20C885 C-884	C-863.12 C-885 with C-863.20C885 C-884 ACS modular controller	C-863.12 C-885 with C-863.20C885 C-884 ACS modular controller	C-891.130300 C-885 with C-891.11C885 ACS modular controller	C-663.12 C-885 with C-663.12C885 ACS modular controller	C-663.12 C-885 with C-663.12C885 ACS modular controller

At PI, technical data is specified at 22 ±3 °C. Unless otherwise stated, the values are for unloaded conditions. Some properties are interdependent. The designation "typ." indicates a statistical average for a property; it does not indicate a guaranteed value for every product supplied. During the final inspection of a product, only selected properties are analyzed, not all. Please note that some product characteristics may deteriorate with increasing operating time.

Drawings / Images

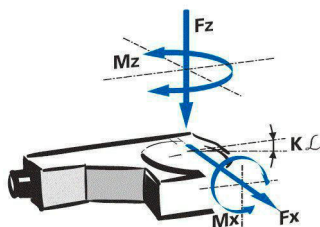

Direction of the axes and torques for rotation stages

Drawings / Images

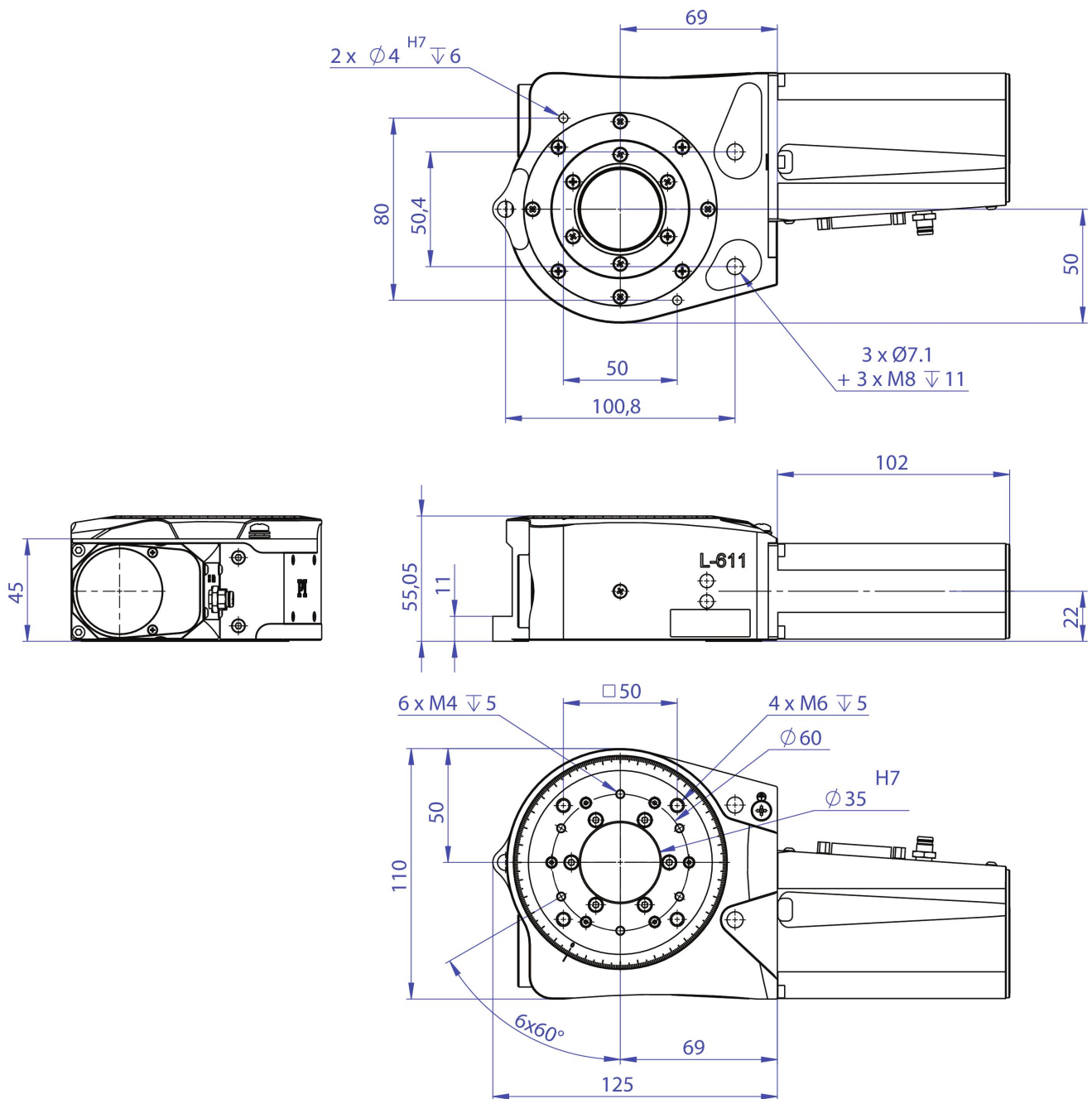

L-611 mit Active Drive DC-Motor, Abmessungen in mm

Drawings / Images

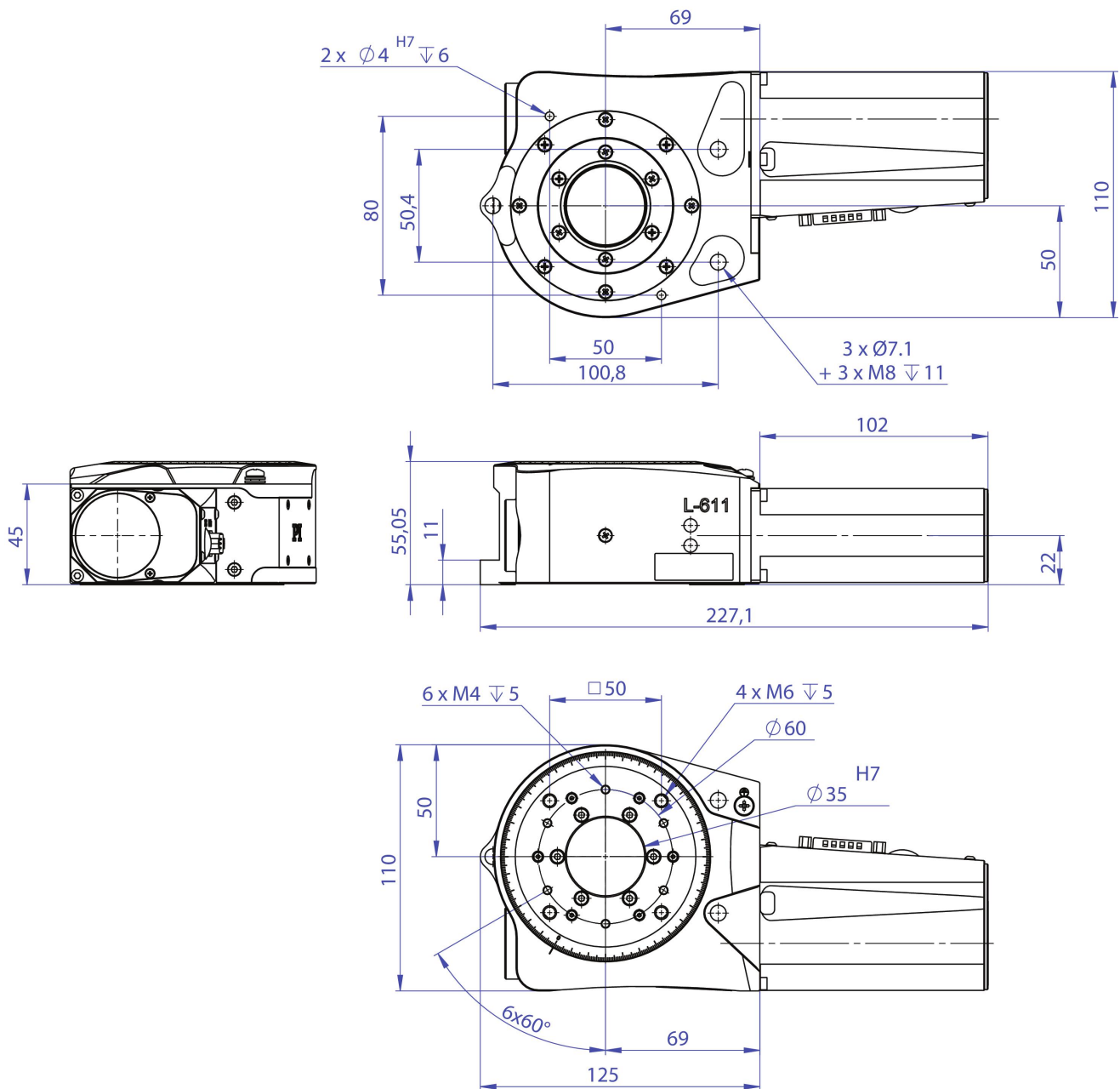

L-611 mit DC- und BLDC-Motor, Abmessungen in mm

Drawings / Images

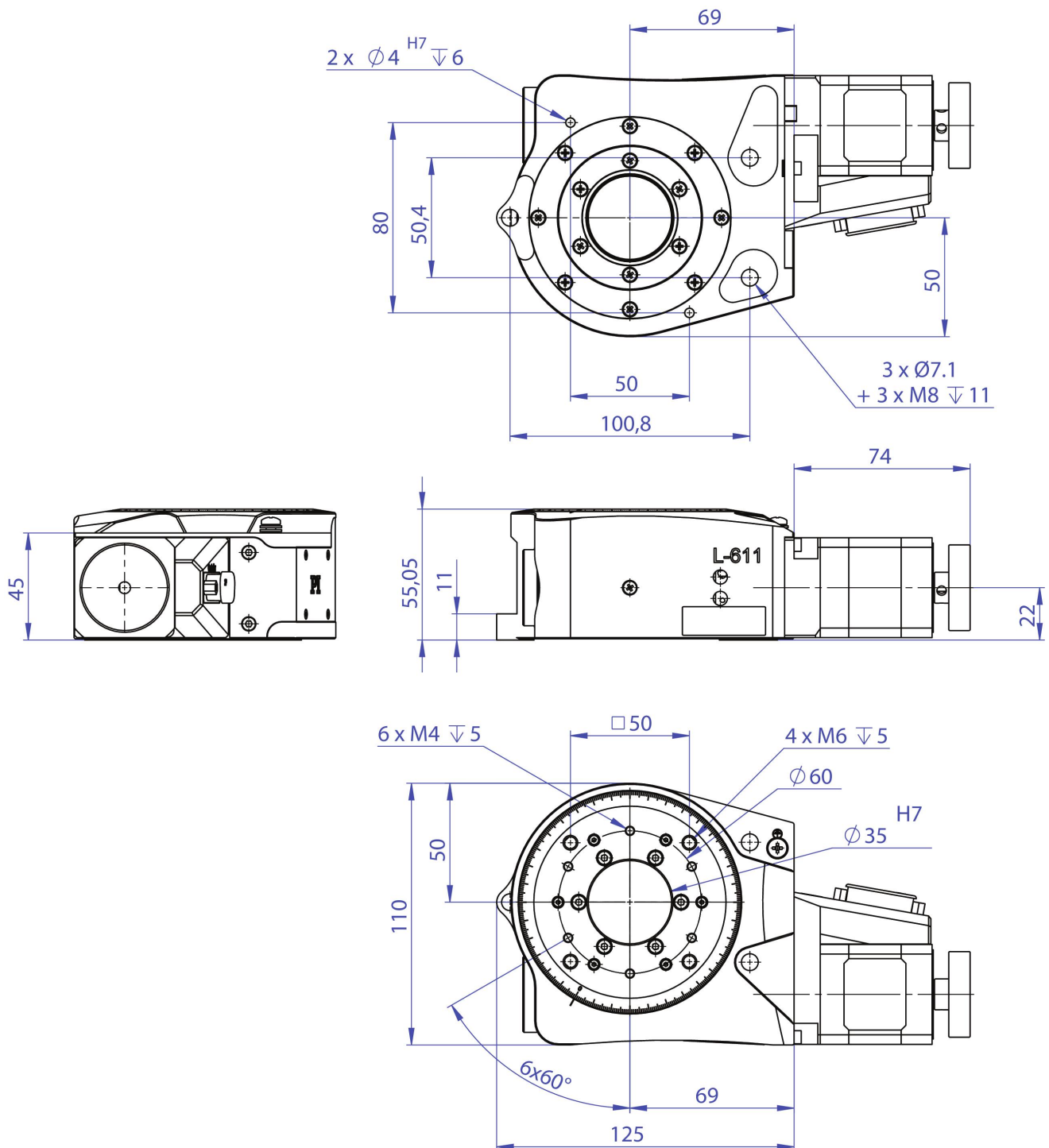

L-611 mit 2-Phasen-Schrittmotor, Abmessungen in mm

Order Information

L-611.90AD

Precision rotation stage; DC motor with ActiveDrive; 360° rotational angle; 100 N load capacity; 200 °/s maximum angular velocity; incremental rotary encoder, 20000 cts./rev. sensor resolution, A/B quadrature, RS-422; 35 mm Ø aperture

L-611.94AD

Precision rotation stage; DC motor with ActiveDrive; 360° rotational angle; 100 N load capacity; 200 °/s maximum angular velocity; incremental angle measuring system, A/B quadrature, RS-422; 35 mm Ø aperture

L-611.993232

Precision rotation stage; DC motor; 360° rotational angle; 100 N load capacity; 200 °/s maximum angular velocity; incremental rotary encoder, 20000 cts./rev. sensor resolution, A/B quadrature, RS-422; 35 mm Ø aperture

L-611.993261

Precision rotation stage; DC motor; 360° rotational angle; 100 N load capacity; 200 °/s maximum angular velocity; incremental angle measuring system, sin/cos, 1 V peak-peak; 35 mm Ø aperture

L-611.995232

Precision rotation stage; brushless DC motor; 360° rotational angle; 100 N load capacity; 200 °/s maximum angular velocity; incremental rotary encoder, 20000 cts./rev. sensor resolution, A/B quadrature, RS-422; 35 mm Ø aperture

L-611.9ASD

Precision rotation stage; 2-phase stepper motor; 360° rotational angle; 100 N load capacity; 50 °/s maximum angular velocity; incremental angle measuring system, sin/cos, 1 V peak-peak; 35 mm Ø aperture

L-611.90SD

Precision rotation stage; 2-phase stepper motor; 360° rotational angle; 100 N load capacity; 50 °/s maximum angular velocity; 35 mm Ø aperture