

PILine® Linear Stage

Compact Linear Stage with Ultrasonic Piezo Motor



U-521

- Positions small loads quickly and with precision: Velocity to 200 mm/s, minimum incremental motion to 0.3 μm
- Space-saving: Only 35 mm in width and 15 mm in height
- Self-locking when switched off: Saves energy and reduces generation of heat
- Silent
- Customized versions on request

Precision-class linear positioning stage

PILine® stages are particularly suitable for applications that require fast precision positioning. When switched off, the self-locking drive holds the position of the stage mechanically stable. Energy consumption and heat generation are therefore considerably reduced. Applications with a low duty cycle that are battery-powered or heat-sensitive benefit from these characteristics. The position of the axis is measured by an encoder and an optical reference switch allows reliable repeatable motion. The piezomotor drive principle and its electrical operation are inexpensive and can be customized.

PILine® ultrasonic piezomotor

An integral part of a PILine® ultrasonic piezomotor is a piezo actuator that is preloaded against a movable, guided runner via a coupling element. The piezoceramic actuator is excited to ultrasonic oscillation by a high-frequency AC voltage between 100 and 200 kHz. Deformation of the actuator leads to periodic diagonal motion of the coupling element relative to the runner. The feed created is a few nanometers per cycle; the high frequencies lead to the high velocities. Preloading the piezoceramic actuator against the runner ensures self-locking of the drive when at rest and switched off.

Highly accurate position measuring with incremental linear encoder

Noncontact optical encoders measure the position directly at the platform with the greatest accuracy. Nonlinearity, mechanical play or elastic deformation have no influence on the measurement.

Application fields

Micromanipulation, automation, biotechnology, sample manipulation, sample positioning, applications with limited space, vacuum applications to 10⁻⁶ hPa (optional).

Motion	Unit	Tolerance	U-521.23	U-521.23V	U-521.24
Active axes			X	X	X
Travel range in X	mm		18	18	18
Maximum velocity in X	mm/s		200	200	200
Linearity error	μm		8	8	4
Angular error around Y (pitch)	μrad	Typ.	±300	±300	±300
Angular error around Z (yaw)	μrad	Typ.	±300	±300	±300

Positioning	Unit	Tolerance	U-521.23	U-521.23V	U-521.24
Minimum incremental motion in X	µm	Typ.	2	2	0.3
Bidirectional repeatability in X	µm	Typ.	4	4	0.4
Reference switch			Optical	Optical	Optical
Integrated sensor			Incremental linear encoder	Incremental linear encoder	Incremental linear encoder
System resolution in X	nm		400	400	100
Sensor resolution	nm		400	400	100

Drive properties	Unit	Tolerance	U-521.23	U-521.23V	U-521.24
Drive type			PILine® piezo motor, performance class 1	PILine® piezo motor, performance class 1	PILine® piezo motor, performance class 1
Drive force in X	N	Typ.	2	2	2

Mechanical properties	Unit	Tolerance	U-521.23	U-521.23V	U-521.24
Permissible push force in Z	N	Max.	2	2	2
Permissible pull force in Z	N	Max.	2	2	2
Holding force in X, passive	N	Min.	2	2	2
Guide			Ball guide	Ball guide	Ball guide
Overall mass	g		160	160	160
Mass without cable	g		40	40	40
Material			Aluminum, anodized	Aluminum, uncoated	Aluminum, anodized

Miscellaneous	Unit		U-521.23	U-521.23V	U-521.24
Operating temperature range	°C		0 to 40	0 to 40	0 to 40
Vacuum class	hPa		—	10 ⁻⁶	—
Connector			D-sub 15 (m)	D-sub 15 (m)	D-sub 15 (m)
Cable length	m		1.5	1	1.5
Recommended controllers/drivers			C-867.1U, C-877.1U11, C-867.10C885, C-867.2U2	C-867.1U, C-877.1U11, C-867.10C885, C-867.2U2	C-867.1U, C-877.1U11, C-867.10C885, C-867.2U2

Linearity error: Over the entire travel range.

Cable length:

Tolerance with cable length 1.5 m: +200 mm / -0 mm

Tolerance with cable length 1.0 m: +50 mm / -0 mm

Specifications determined with the C-867.1U controller.

At PI, technical data is specified at 22 ±3 °C. Unless otherwise stated, the values are for unloaded conditions. Some properties are interdependent. The designation "typ." indicates a statistical average for a property; it does not indicate a guaranteed value for every product supplied. During the final inspection of a product, only selected properties are analyzed, not all. Please note that some product characteristics may deteriorate with increasing operating time.

Drawings / Images

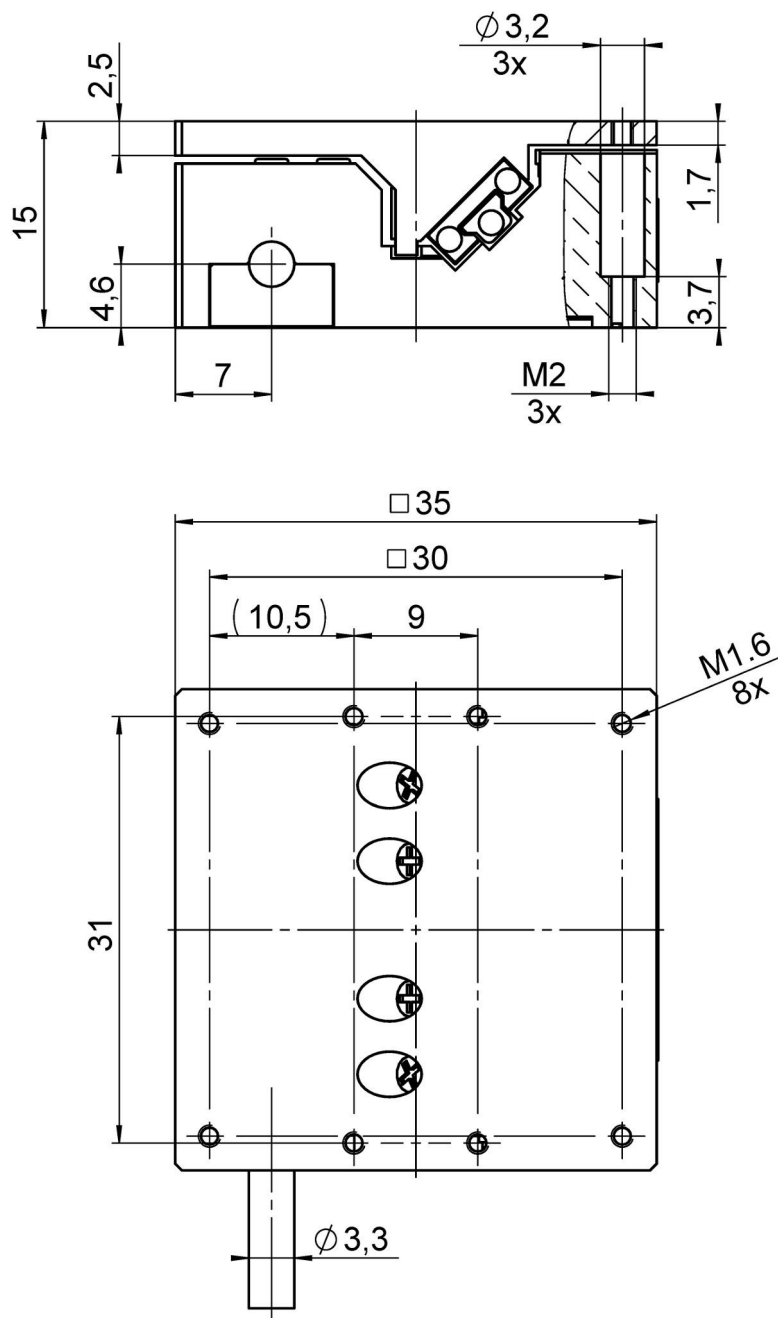

U-521, dimensions in mm. Note that a comma is used in the drawings instead of a decimal point.

Drawings / Images



Multi-axis setup consisting of two U-521 linear stages and a U-624 rotation stage, without adapter plate

Order Information

U-521.23

PLine® linear stage; PLine® piezo motor, performance class 1; 18 mm travel range; 2 N load capacity; 200 mm/s maximum velocity; incremental linear encoder, 400 nm sensor resolution; 1.5 m cable length

U-521.23V

PLine® linear stage; PLine® piezo motor, performance class 1; 18 mm travel range; 2 N load capacity; 200 mm/s maximum velocity; incremental linear encoder, 400 nm sensor resolution; vacuum-compatible to 10 hPa; 1 m cable length

U-521.24

PLine® linear stage; PLine® piezo motor, performance class 1; 18 mm travel range; 2 N load capacity; 200 mm/s maximum velocity; incremental linear encoder, 100 nm sensor resolution; 1.5 m cable length