

NEXLINE® OEM Linear Actuator

Nanopositioning Over Long Travel Ranges, PiezoWalk® Principle



N-111

- Travel range 10 mm
- Integrated direct-measuring linear encoder with resolution 5 nm
- Force generation to 50 N
- Holding force to 70 N

Application fields

- Industrial precision positioning
- Semiconductor technology
- Semiconductor tests
- Wafer inspection
- Lithography
- Nanoimprinting
- Nanometrology
- Motion in strong magnetic fields and in a vacuum

Nanometer precision and high feed force with PiezoWalk® walking drives

Several piezo actuators perform a walking motion in the PiezoWalk® walking drive that leads to forward feed of a runner. Control of the actuators allows the smallest step and forward feed motion at a resolution of well under one nanometer.

Highly accurate position measuring with incremental linear encoder

Noncontact optical encoders measure the position directly at the platform with the greatest accuracy. Nonlinearity, mechanical play or elastic deformation have no influence on the measurement.

Suitable for sophisticated vacuum applications

Piezo motors from PI can be designed for use in a vacuum and are suitable for operating in strong magnetic fields. Special versions of the drives are available for this purpose. Piezo walking drives can also be used in cleanrooms or in environments with strong ultraviolet radiation.

Motion	Unit	Tolerance	N-111.201	N-111.2A1
Active axes			X	X
Travel range in X	mm		10	10
Travel range in X (analog mode)	µm		±2	±2
Velocity (10 % duty cycle, full-step mode)	mm/s	Max.	1	1
Velocity (100 % duty cycle, full-step mode)	mm/s	Max.	0.6	0.6
Velocity (100 % duty cycle, nanostepping mode)	mm/s	Max.	0.4	0.4

Positioning	Unit	Tolerance	N-111.201	N-111.2A1
Reference switch			—	Optical, direction sensing (reference edge track), 5 V, TTL
Resolution in X, open loop	nm	Typ.	0.025	0.025
Integrated sensor			—	Incremental linear encoder
System resolution in X	nm		—	5

Drive properties	Unit	Tolerance	N-111.201	N-111.2A1
Drive type			NEXLINE® piezo walking drive	NEXLINE® piezo walking drive
Operating voltage	V		-250 to +250	-250 to +250
Drive force in X	N	Max.	50	50

Mechanical properties	Unit	Tolerance	N-111.201	N-111.2A1
Holding force in X, passive	N	Min.	70	70
Overall mass	g		245	325
Material			Aluminum, stainless steel, titanium	Aluminum, stainless steel, titanium

Miscellaneous	Unit	Tolerance	N-111.201	N-111.2A1
Operating temperature range	°C		0 to 55	0 to 55
Connector			D-sub 25 (m)	D-sub 25 (m)
Cable length	m	+50 mm / -0 mm	1.5	1.5
Recommended controllers/ drivers			E-713	E-713

Velocity in full-step mode Depending on drive electronics.

Velocity in nanostepping mode: Depending on drive electronics. The maximum velocity in nanostepping mode is designed for the best possible constancy so that no velocity variations occur when executing the steps.

Drive force: Data refer to operation in full step mode.

At PI, technical data is specified at 22 ±3 °C. Unless otherwise stated, the values are for unloaded conditions. Some properties are interdependent. The designation "typ." indicates a statistical average for a property; it does not indicate a guaranteed value for every product supplied. During the final inspection of a product, only selected properties are analyzed, not all. Please note that some product characteristics may deteriorate with increasing operating time.

Drawings / Images

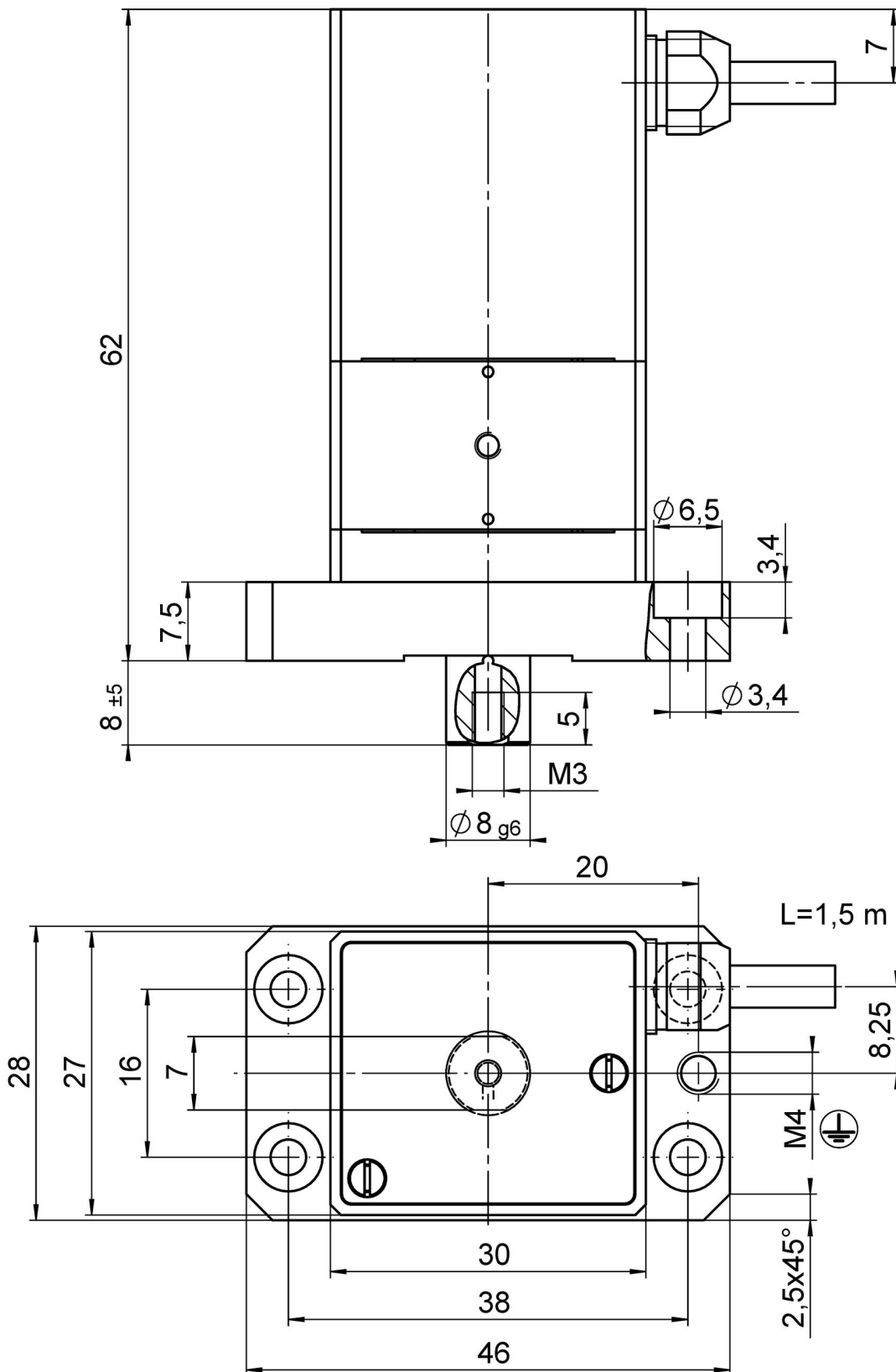

N-111.2A1, dimensions in mm. Note that a comma is used in the drawings instead of a decimal point.

Drawings / Images

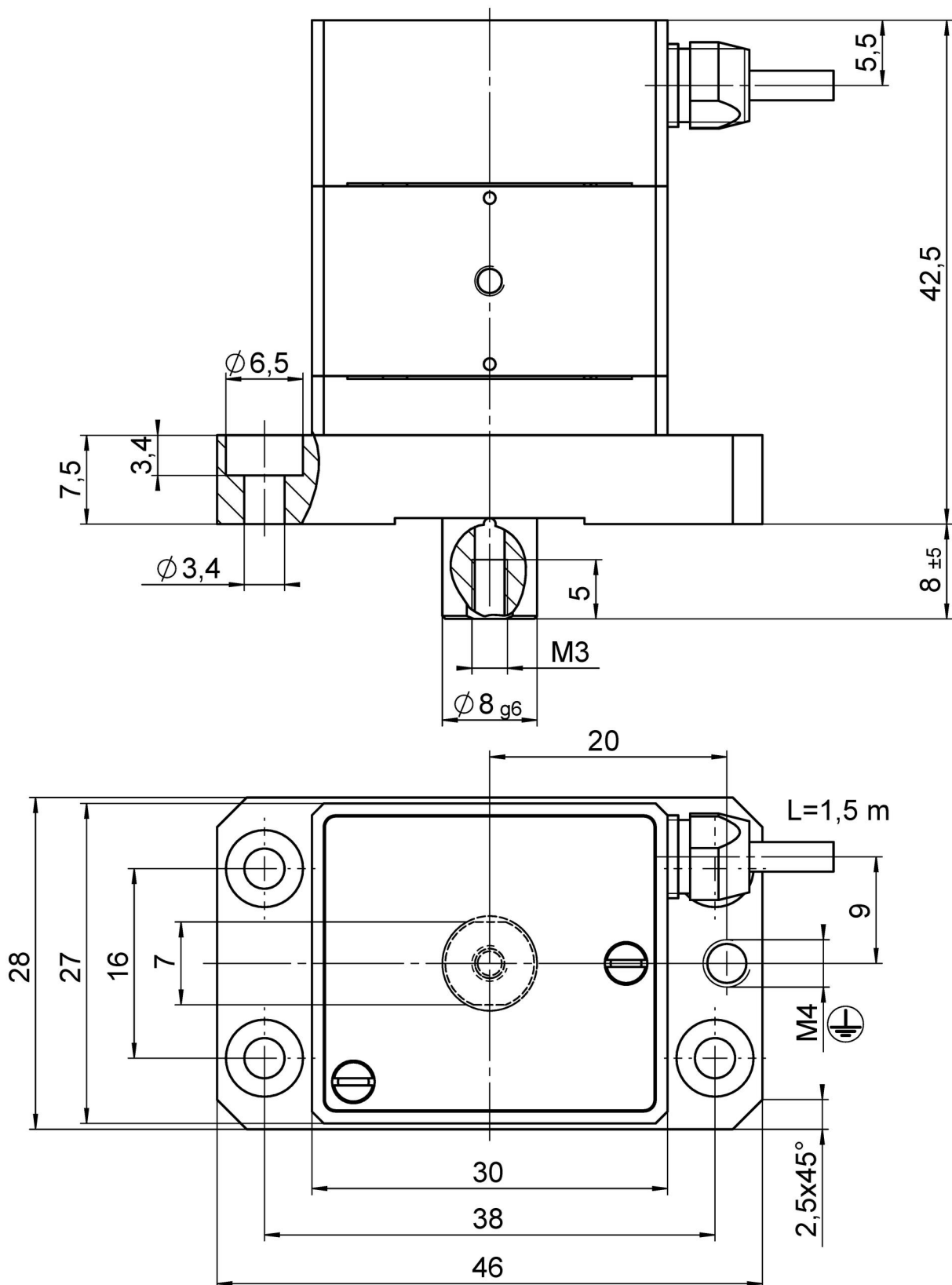

N-111.201, dimensions in mm. Note that a comma is used in the drawings instead of a decimal point.

Order Information

N-111.201

NEXLINE® OEM linear actuator; NEXLINE® piezo walking drive; 10 mm travel range; 50 N feed force; 1.5 m cable length

N-111.2A1

NEXLINE® OEM linear actuator; NEXLINE® piezo walking drive; 10 mm travel range; 50 N feed force; incremental linear encoder; 1.5 m cable length