

PZ256E S-331 Piezo Tip/Tilt Platform User Manual

Version: 1.1.0

Date: 07.08.2018



This document describes the following products:

- **S-331.2SH**
High-dynamics tip/tilt platform with high stiffness, 3 mrad tip/tilt angle, strain gauge sensor, Sub-D 37 connector (m)
- **S-331.2SL**
High-dynamics tip/tilt platform with high stiffness, 3 mrad tip/tilt angle, strain gauge sensor, LEMO connectors
- **S-331.5SH**
High-dynamics tip/tilt platform with high stiffness, 5 mrad tip/tilt angle, strain gauge sensor, Sub-D 37 connector (m)
- **S-331.5SL**
High-dynamics tip/tilt platform with high stiffness, 5 mrad tip/tilt angle, strain gauge sensor, LEMO connectors



The following company names and brands are registered trademarks of Physik Instrumente (PI) GmbH & Co. KG:

PI[®], NanoCube[®], PICMA[®], PILine[®], NEXLINE[®], PiezoWalk[®], NEXACT[®], Picoactuator[®], Plnano[®], PIMag[®], Q-Motion[®]

© 2018 Physik Instrumente (PI) GmbH & Co. KG, Karlsruhe, Germany. The text, photographs, and drawings in this manual are protected by copyright. With regard thereto, Physik Instrumente (PI) GmbH & Co. KG retains all the rights. The use of any text, images and drawings is permitted only in part and only when indicating the source.

Original instructions

First printing: 07.08.2018

Document number: PZ256E, KSch, Version 1.1.0

Subject to change without notice. This manual is superseded by any new release. The latest release is available for download (p. 3) on our website.

Contents

1	About this Document	1
1.1	Objective and Target Audience of this User Manual.....	1
1.2	Symbols and Typographic Conventions.....	1
1.3	Figures	2
1.4	Other Applicable Documents	2
1.5	Downloading Manuals.....	3
2	Safety	5
2.1	Intended Use	5
2.2	General Safety Instructions	5
2.3	Organizational Measures.....	6
3	Product Description	7
3.1	Model Overview	7
3.2	Product View	8
3.3	Product Labeling.....	9
3.4	Scope of Delivery.....	11
3.5	Accessories	11
3.6	Suitable Electronics	13
3.7	Control.....	14
3.8	ID Chip	15
3.9	Dynamic Behavior.....	15
3.9.1	Calculating Moments of Inertia for Mirror and Mirror Holder.....	16
3.9.2	Calculating the Resonant Frequency of the Tip/Tilt Platform	19
4	Unpacking	21
5	Installation	23
5.1	General Notes on Installation.....	23
5.2	Mounting the Mirror on the S-331.....	25
5.3	Mounting the S-331.....	29
5.4	Connecting the S-331 to the Protective Earth Conductor.....	30
5.5	Connecting the S-331 to the Controller	31
6	Startup and Operation	33
6.1	General Notes on Startup and Operation	33
6.2	Operating the S-331	35
6.3	Discharging the S-331.....	35

7	Maintenance	37
7.1	General Notes on Maintenance	37
7.2	Cleaning the S-331.....	37
8	Troubleshooting	39
9	Customer Service	41
10	Technical Data	43
10.1	Specifications.....	43
10.1.1	Data Table.....	43
10.1.2	Maximum Ratings.....	45
10.1.3	Ambient Conditions and Classifications	45
10.1.4	Recommended Control Signals for Dynamic Operation.....	46
10.2	Dimensions.....	47
10.2.1	S-331.....	47
10.2.2	S-330.Xx	48
10.3	Pin Assignment	49
10.3.1	S-331.xSH: Sub-D 37 (m) Piezo and Sensor Connection	49
10.3.2	S-331.xSL: LEMO Piezo and Sensor Connections.....	51
11	Old Equipment Disposal	53
12	EU Declaration of Conformity	55

1 About this Document

In this Chapter

Objective and Target Audience of this User Manual	1
Symbols and Typographic Conventions	1
Figures	2
Other Applicable Documents	2
Downloading Manuals	3

1.1 Objective and Target Audience of this User Manual

This user manual contains the information needed for the intended use of the S-331. Basic knowledge of servo systems, drive technologies, and suitable safety measures is assumed.

1.2 Symbols and Typographic Conventions

The following symbols and typographic conventions are used in this user manual:

CAUTION



Dangerous situation

If not avoided, the dangerous situation will result in minor injury.

- Actions to take to avoid the situation.

NOTICE



Dangerous situation

If not avoided, the dangerous situation will result in damage to the equipment.

- Actions to take to avoid the situation.

INFORMATION

Information for easier handling, tricks, tips, etc.

Symbol/ Label	Meaning
1. 2.	Action consisting of several steps whose sequential order must be observed
➤	Action consisting of one or several steps whose sequential order is irrelevant
▪	List item
p. 5	Cross-reference to page 5
RS-232	Labeling of an operating element on the product (example: socket of the RS-232 interface)
	Warning signs affixed to the product that refer to detailed information in this manual.

1.3 Figures

For better understandability, the colors, proportions, and degree of detail in illustrations can deviate from the actual circumstances. Photographic illustrations may also differ and must not be seen as guaranteed properties.

1.4 Other Applicable Documents

The devices and software tools that are mentioned in this documentation are described in their own manuals.

Product	Document
E-727.3SD/E-727.3SDA Digital Multi-Channel Piezo Controllers for SGS	E727T0005 Technical Note
E-509.S3 Sensor/Servo Controller Module	PZ77E User Manual
E-503.00S Piezo Amplifier Module	PZ62E User Manual
E-505.00 Piezo Amplifier Module	
E-505.00S Offset Voltage Source for Tip/Tilt Platforms	
E-501.00 9.5" Chassis for Modular Piezo Controller System	
E-500.00 19" Chassis for Modular Piezo Controller System, 1 to 3 channels	
E-518.I3 Interface Module	E518T0001 Technical Note, PZ214E User Manual
S-330.X1 and S-330.X2 Centering Aids for Mirror Mounting	S330T0024 Technical Note

The latest versions of the user manuals are available on our website for download (p. 3).

1.5 Downloading Manuals

INFORMATION

If a manual is missing or problems occur with downloading:

- Contact our customer service department (p. 41).

INFORMATION

For products that are supplied with software (CD in the scope of delivery), access to the manuals is protected by a password. Protected content is only displayed on the website after entering the access data.

You need the product CD to get the access data.

For products with CD: Get access data

1. Insert the product CD into the PC drive.
2. Switch to the Manuals directory on the CD.
3. In the Manuals directory, open the Release News (file including *releasenews* in the file name).
4. Get the access data for downloading protected content in the "User login for software download" section of the Release News. Possible methods for getting:
 - Link to a page for registering and requesting the access data
 - Direct input of user name and password
5. If the access data needs to be requested via a registration page:
 - a) Follow the link in the Release News.
 - b) Enter the required information in the browser window.
 - c) Click **Show login data** in the browser window.
 - d) Note the user name and password shown in the browser window.

Downloading manuals

If you have requested access data for protected contents via a registration page (see above):

- Click the links in the browser window to change to the content for your product and log in using the access data that you received.

General procedure:

1. Open the website **www.pi.ws**.

2. If access to the manuals is protected by a password:
 - a) Click **Login**.
 - b) Log in with the user name and password.
3. Click **Search**.
4. Enter the product number up to the period (e.g., P-882) or the product family (e.g., PICMA® Bender) into the search field.
5. Click **Start search** or press the **Enter** key.
6. Open the corresponding product detail page in the list of search results:
 - a) If necessary: Scroll down the list.
 - b) If necessary: Click **Load more results** at the bottom of the list.
 - c) Click the corresponding product in the list.
7. Click the **Downloads** tab.

The manuals are shown under **Documentation**.
8. Click the desired manual and save it to the hard disk of your PC or to a data storage medium.

2 Safety

In this Chapter

Intended Use.....	5
General Safety Instructions.....	5
Organizational Measures.....	6

2.1 Intended Use

The S-331 is a laboratory device as defined by DIN EN 61010-1. It is intended for indoor use and use in an environment that is free of dirt, oil, and lubricants.

In accordance with its design, the S-331 is intended for the precise positioning and alignment of a mirror in two orthogonal axes with a common pivot point (parallel kinematics). The S-331 is suitable for highly dynamic applications and can be mounted in any orientation.

The S-331 is delivered without a mirror and is intended for the attachment of a suitable mirror (p. 25). The models of the S-331 are equipped with strain gauge sensors (SGS).

The intended use of the S-331 is only possible in conjunction with suitable electronics (p. 13) that are available from PI. The electronics are not included in the scope of delivery of the S-331.

The electronics must provide the required operating voltages. To ensure proper performance of the servo-control system, the electronics must also be able to read out and process the signals from the strain gauge sensors.

2.2 General Safety Instructions

The S-331 is built according to state-of-the-art technology and recognized safety standards. Improper use can result in personal injury and/or damage to the S-331.

- Only use the S-331 for its intended purpose, and only use it if it is in a good working order.
- Read the user manual.
- Immediately eliminate any faults and malfunctions that are likely to affect safety.

The operator is responsible for the correct installation and operation of the S-331.

2.3 Organizational Measures

User manual

- Always keep this user manual available with the S-331. The latest versions of the user manuals are available for download (p. 3) on our website.
- Add all information from the manufacturer to the user manual, for example supplements or technical notes.
- If you give the S-331 to other users, also include this user manual as well as other relevant information provided by the manufacturer.
- Only use the device on the basis of the complete user manual. Missing information due to an incomplete user manual can result in minor injury and damage to equipment.
- Only install and operate the S-331 after you have read and understood this user manual.

Personnel qualification

The S-331 may only be installed, started up, operated, maintained, and cleaned by authorized and appropriately qualified personnel.

3 Product Description

In this Chapter

Model Overview.....	7
Product View.....	8
Product Labeling.....	9
Scope of Delivery	11
Accessories.....	11
Suitable Electronics.....	13
Control	14
ID Chip.....	15
Dynamic Behavior	15

3.1 Model Overview

Four standard versions of the S-331 piezo tip/tilt platform are available.

Model	Description
S-331.2SH	High-dynamics tip/tilt platform with high stiffness, 3 mrad tip/tilt angle, strain gauge sensor, Sub-D 37 connector (m)
S-331.2SL	High-dynamics tip/tilt platform with high stiffness, 3 mrad tip/tilt angle, strain gauge sensor, LEMO connectors
S-331.5SH	High-dynamics tip/tilt platform with high stiffness, 5 mrad tip/tilt angle, strain gauge sensor, Sub-D 37 connector (m)
S-331.5SL	High-dynamics tip/tilt platform with high stiffness, 5 mrad tip/tilt angle, strain gauge sensor, LEMO connectors

- For further technical data, see the specifications (p. 43).

3.2 Product View



Figure 1: Product view of the S-331.2SH



Figure 2: Product view of the S-331.5SH

- 1 Protective earth connection
- 2 Housing
- 3 Motion platform with groove for gluing the mirror
- 4 M1.6 threaded hole for mounting a mirror holder
- 5 Cable exit

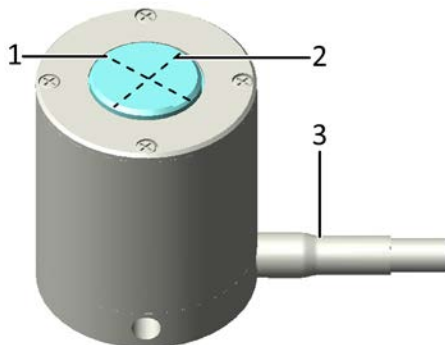

Figure 3: Schematic diagram of the axes of the S-331.2SH in relation to the cable exit, identical for further models of the S-331

- 1 Axis 1 (corresponds to axis 1 on the E-727.3SD/A controller)
- 2 Axis 2 (corresponds to axis 2 on the E-727.3SD/A controller)
- 3 Cable exit

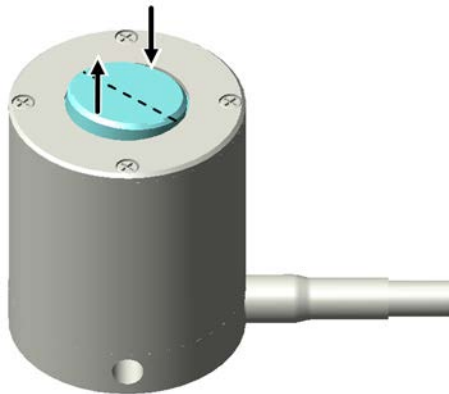

Figure 4: Maximum displacement in the positive direction of motion around axis 1. At the connected channel 1 of the amplifier, the output voltage U_{Piezo} is 100 V. The displacement shown is strongly exaggerated for better understanding.

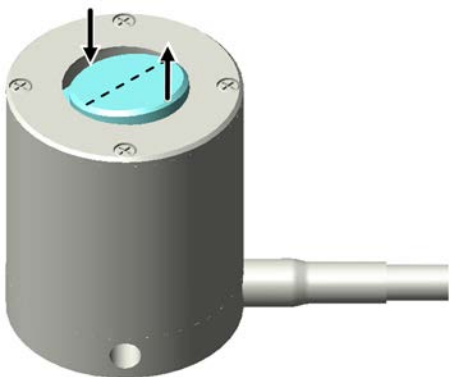

Figure 5: Maximum displacement in the positive direction of motion around axis 2. At the connected channel 2 of the amplifier, the output voltage U_{Piezo} is 100 V. The displacement shown is strongly exaggerated for better understanding.

3.3 Product Labeling

Labeling	Description
S-331.2SH	Product name (example), the characters following the period refer to the model
116010244	Serial number (example), individual for each S-331 Meaning of the places (counting from left): 1 = internal information, 2 and 3 = year of manufacture, 4 to 9 = consecutive numbers

Labeling	Description
PI	Manufacturer's logo
Country of origin: Germany	Country of origin
	Warning sign "Observe manual!"
	Old equipment disposal (p. 53)
CE	CE conformity mark
WWW.PI.WS	Manufacturer's address (website)
	Symbol for the protective earth conductor, marks the protective earth connection of the S-331 (p. 30)

S-331.xSH: Labeling of the Sub-D 37 (m) connector



Figure 6: Sub-D 37 (m) connector on the connection cable of the S-331.xSH

1



Warning sign "Residual Voltage": Notice of risk of electric shock (p. 5)

S-331.xSL: Labeling of the LEMO connection cable

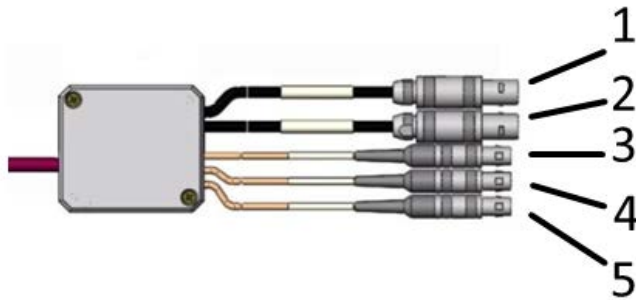

Figure 7: Cable diagram for S-331.xSL

- 1 Sensor connection for axis 2, labeled **AXIS 2**
- 2 Sensor connection for axis 1, labeled **AXIS 1**
- 3 Piezo connection for 100 V fixed voltage, labeled **PZT 100V**
- 4 Piezo connection for axis 2, labeled **PZT2**
- 5 Piezo connection for axis 1, labeled **PZT1**

3.4 Scope of Delivery

Item number	Components
S-331	Tip/tilt platform according to order
000036450	M4 screw set for protective earth, consisting of: <ul style="list-style-type: none"> ▪ 1 flat-head screw with cross recess, M4x8, ISO 7045 ▪ 2 safety washers ▪ 2 flat washers
PZ277EK	Printed short instructions for S-3xx piezo tip/tilt platforms

3.5 Accessories

Order number	Description
S-330.X1	Centering aid for mirror mounting, for the S-330 and S-331 tip/tilt platforms with 0.5" mirror (Ø 12.5 mm)
S-330.X2	Centering aid for mirror mounting, for the S-330 and S-331 tip/tilt platforms with 1.0" mirror (Ø 25.4 mm)

Order number	Description
Only S-331.xxL:	
E-518.I3	Interface module, 3 channels, TCP/IP, USB, and RS-232 interfaces
P-891.01	Extension cable for piezo voltage, LEMO connector(s), 1 m
P-891.02	Extension cable for piezo voltage, LEMO connector(s), 2 m
P-891.03	Extension cable for piezo voltage, LEMO connector(s), 3 m
P-891.05	Extension cable for piezo voltage, LEMO connector(s), 5 m
P-891.10	Extension cable for piezo voltage, LEMO connector(s), 10 m
P-892.01	Extension cable, for strain gauge sensors, LEMO connector(s), 1 m
P-892.02	Extension cable, for strain gauge sensors, LEMO connector(s), 2 m
P-892.03	Extension cable, for strain gauge sensors, LEMO connector(s), 3 m
P-892.05	Extension cable, for strain gauge sensors, LEMO connector(s), 5 m
P-892.10	Extension cable, for strain gauge sensors, LEMO connector(s), 10 m

- To order, contact our customer service department (p. 41).

3.6 Suitable Electronics

Model	Controller	Amplifier	Housing	Interfaces
S-331.xSH	E-727.3SD Digital multi-channel piezo controller, 3 axes, -30 to 130 V, strain gauge sensors, Sub-D 37 socket		221 mm × 240.10 mm × 116.60 mm	-
	E-727.3SDA Digital multi-channel piezo controller, 3 axes, -30 to 130 V, strain gauge sensors, Sub-D 37 socket, analog inputs		221 mm × 240.10 mm × 116.60 mm	-
S-331.xSL	E-509.S3 sensor / servo controller module, strain gauge sensors, 3 channels	E-503.00S piezo amplifier module, -30 to 130 V. customized version, modified for tip/tilt platforms with differential drive: One fixed voltage of +100 V, two variable voltages	E-501.00 9.5" housing for modular piezo controller system, 1 to 3 channels	Optional: E-518.I3 Interface module, 3 channels, TCP/IP, USB, and RS-232 interfaces
	E-509.S3 sensor / servo controller module, strain gauge sensors, 3 channels	2 x E-505.00 Piezo amplifier module, 2 A, -30 to 130 V, 1 channel, 1 x E-505.00S Offset voltage source for tip/tilt platforms, 100 V fixed voltage	E-500.00 19" housing for modular piezo controller system, 1 to 3 channels	Optional: E-518.I3 Interface module, 3 channels, TCP/IP, USB, and RS-232 interfaces

3.7 Control

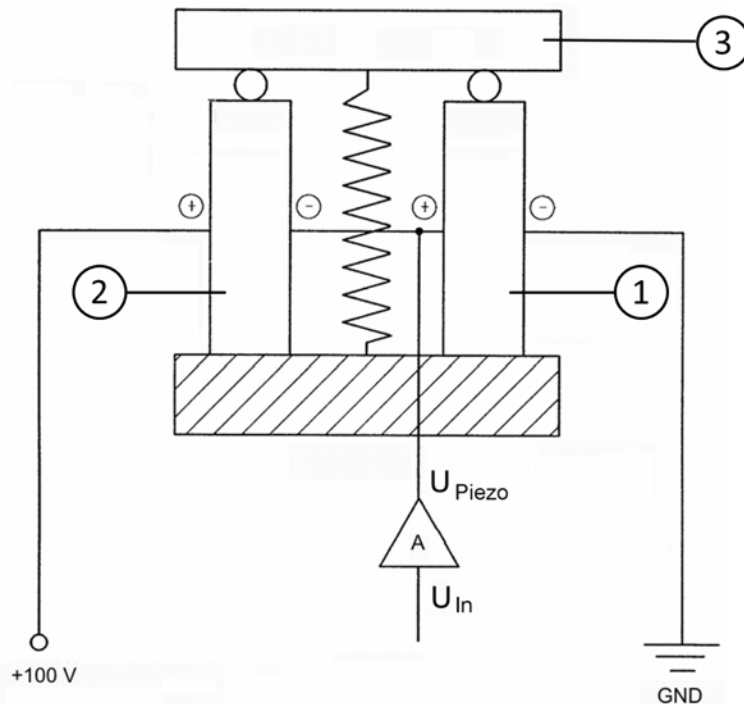

Figure 8: Differential drive of the tip/tilt platform, functional principle using the tilting of a single axis as an example

- 1 Piezo actuator 1 of the axis
- 2 Piezo actuator 2 of the axis
- 3 Motion platform

The S-331 is a tip/tilt platform with differential piezo drive. Four piezo actuators are interconnected in pairs to realize tip/tilt motions on two axes.

Both pairs of actuators are electrically switched so that when piezo voltage U_{Piezo} is changed, the voltage is increased to one actuator of a pair while the voltage to the other actuator is decreased by the same amount. The actuator with the increased voltage expands while the other actuator with the decreased voltage contracts. This produces the tip/tilt motion.

For a simplified representation of the functional principle, only one axis is shown in the figure above. The motion platform is shown with a tilt of 0° .

When the control input voltage U_{in} increases, piezo actuator 1 expands and piezo actuator 2 contracts. This produces a tilt in the positive direction.

Because of the way they are interconnected, both actuator pairs always move in opposite directions. It is therefore **impossible** to command linear motions in the Z axis.

The position of the Z axis can change with temperature fluctuations, however: Due to the symmetrical design of the tip/tilt platform, temperature fluctuations do not cause the motion

platform to tilt but cause the length of the piezo actuators to change evenly in the direction of the Z axis.

Most applications are not very sensitive to such deviations as long as the tip/tilt angle does not change.

Each of the four piezo actuators of the S-331 is equipped with a strain gauge sensor. Therefore, in addition to the amplifier channel, a servo loop with a sensor channel must be available for each actuator pair.

3.8 ID Chip

An ID chip is located in the Sub-D connector of the S-331. When the S-331 is calibrated at the factory with digital electronics, the calibration data is saved on the ID chip together with specific product information. During switch-on, the digital electronics read the data from the ID chip of the S-331 connected. An S-331, whose ID chip contains the calibration data, can therefore be connected to any suitable digital electronics without renewed calibration.

For more information on the ID chip, see the manual of the controller used.

3.9 Dynamic Behavior

The maximum operating frequency of a piezo tip/tilt platform depends on the following factors:

- Bandwidth of amplifier, controller, and sensor
- Resonant frequency of the tip/tilt platform including mirror and where appropriate, mirror holder

The resonant frequency is estimated in two steps:

- a) Calculating the moments of inertia for mirror and mirror holder (p. 16)
- b) Calculating (p. 19) resonant frequency of the tip/tilt platform including mirror and mirror holder.

3.9.1 Calculating Moments of Inertia for Mirror and Mirror Holder

Calculating the distance from the axis through the center of gravity of the mirror to the rotational axis

Before the moment of inertia of the mirror is calculated, it is necessary to calculate the distance from the axis through the center of gravity of the mirror to the rotational axis of the platform. When a mirror holder is used, it must be included in the calculation.

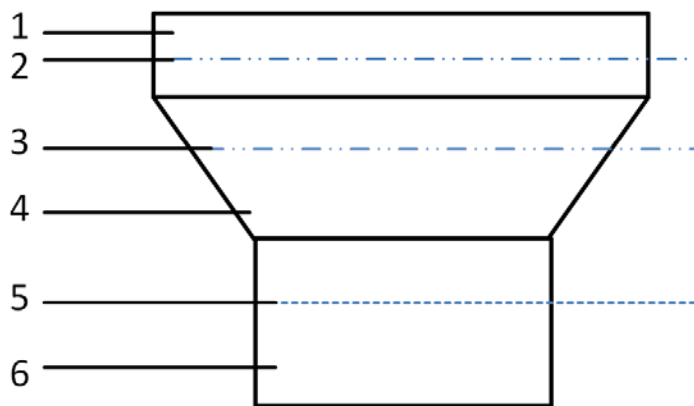

Figure 9: Example diagram: Platform with mirror holder and mirror

- 1 Mirror
- 2 Axis through the center of gravity of the mirror
- 3 Axis through the center of gravity of the mirror holder
- 4 Mirror holder (example of a geometry)
- 5 Axis through the pivot point of the platform of the S-331 ("rotational axis")
- 6 Platform

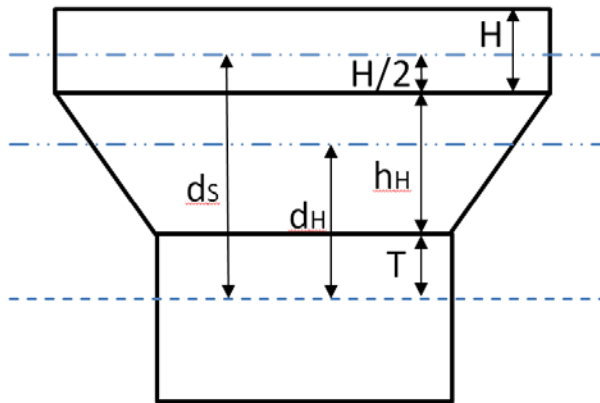

Figure 10: Example diagram: Platform with mirror holder and mirror; here with variables required for calculating the moments of inertia

- d_S Distance from the axis through the center of gravity of the mirror to the rotational axis
- d_H Distance from the axis through the center of gravity of the mirror holder to the rotational axis
- $H/2$ Half the mirror thickness
- h_H Thickness of the mirror holder
- T Distance from the rotational axis to the platform surface (see "Data Table" (p. 43))
- H Mirror thickness

Formula for calculating the distance from the axis through the center of gravity of the mirror to the rotational axis of the platform:

When a mirror is attached **without** a mirror holder:

$$d_S = \frac{H}{2} + T$$

When a mirror is attached **with** a mirror holder:

$$d_S = \frac{H}{2} + h_H + T$$

with:

d_S = Distance from the axis through the center of gravity of the mirror to the rotational axis [mm]

H = Mirror thickness [mm]

h_H = Thickness of the mirror holder [mm]

T = Distance from the rotational axis to the platform surface [mm], see "Data Table" (p. 43)

Calculating the moment of inertia of the mirror

Formula for calculating the moment of inertia of a rotationally symmetric mirror:

$$I_{S,P} = m_S \left[\frac{3R^2 + H^2}{12} + d_S^2 \right]$$

Formula for calculating the moment of inertia of a rectangular mirror:

$$I_{S,P} = m_S \left[\frac{L^2 + H^2}{12} + d_S^2 \right]$$

with:

$I_{S,P}$ = Moment of inertia of the mirror, in relation to the rotational axis [$\text{g} \cdot \text{mm}^2$]

m_S = Mirror mass [g]

R = Mirror radius [mm]

L = Mirror length perpendicular to the rotational axis [mm]

H = Mirror thickness [mm]

d_S = Distance from the axis through the center of gravity of the mirror to the rotational axis [mm]; for calculation see separate formulas (p. 16)

Calculating the moment of inertia of the mirror holder

$$I_{H,P} = I_H + m_H * (d_H)^2$$

with:

$I_{H,P}$ = Moment of inertia of the mirror holder, in relation to the rotational axis [$\text{g} \cdot \text{mm}^2$]

I_H = Moment of inertia of the mirror holder, dependent on the geometry of the mirror holder [$\text{g} \cdot \text{mm}^2$]

m_H = Mass of the mirror holder [g]

d_H = Distance from the axis through the center of gravity of the mirror holder to the rotational axis of the platform [mm], see above illustration (p. 16)

3.9.2 Calculating the Resonant Frequency of the Tip/Tilt Platform

Mirror without mirror holder

When the mirror is mounted without a mirror holder, the resonant frequency of the system is calculated with the following formula:

$$f' = \frac{f_0}{\sqrt{1 + \frac{I_{S,P}}{I_0}}}$$

with:

f' = Resonant frequency of the S-331 with mirror [Hz]

f_0 = Resonant frequency of the unloaded S-331 [Hz]; see "Data Table" (p. 43)

I_0 = Moment of inertia of the platform of the S-331 [$\text{g}\cdot\text{mm}^2$], see "Data Table" (p. 43)

$I_{S,P}$ = Moment of inertia of the mirror, in relation to the rotational axis, [$\text{g}\cdot\text{mm}^2$]; calculation see separate formulas (p. 18)

Mirror with mirror holder

When the mirror is mounted with a mirror holder, the resonant frequency of the tip/tilt platform is calculated with the following formula:

$$f' = \frac{f_0}{\sqrt{1 + \frac{(I_{S,P} + I_{H,P})}{I_0}}}$$

with:

f' = Resonant frequency of the S-331 with mirror and mirror holder [Hz]

f_0 = Resonant frequency of the unloaded S-331 [Hz], see "Data Table" (p. 43)

I_0 = Moment of inertia of the platform of the S-331 [$\text{g}\cdot\text{mm}^2$], see "Data Table" (p. 43)

$I_{S,P}$ = Moment of inertia of the mirror, in relation to the rotational axis, [$\text{g}\cdot\text{mm}^2$]; for calculation see separate formulas (p. 18)

$I_{H,P}$ = Moment of inertia of the mirror holder, in relation to the rotational axis, [$\text{g}\cdot\text{mm}^2$]; calculation see separate formula (p. 18)

Further information on dynamic or static operation can be found in the PI catalog (CAT 130), in the section "Fundamentals of Piezo Technology". The catalog can be downloaded from our website <http://www.pi.ws> under **Service > Downloads > Catalogs, Brochures & Certificates**.

4 Unpacking

1. Unpack the S-331 with care.
2. Compare the contents with the items listed in the contract and the packing list.
3. Inspect the contents for signs of damage. If parts are missing or you notice signs of damage, contact PI immediately.
4. Keep all packaging materials in case the product needs to be returned.

5 Installation

In this Chapter

General Notes on Installation	23
Mounting the Mirror on the S-331	25
Mounting the S-331	29
Connecting the S-331 to the Protective Earth Conductor	30
Connecting the S-331 to the Controller	31

5.1 General Notes on Installation

CAUTION



Dangerous voltage and residual charge in piezo actuators!

The S-331 is driven by piezo actuators. Temperature changes and compressive stresses can induce charges in piezo actuators. After disconnection from the electronics, piezo actuators can remain charged for several hours. Touching or short-circuiting the contacts in the connector of the S-331 can lead to minor injuries from electric shock. The piezo actuators can be destroyed by an abrupt contraction.

- Do **not** open the S-331.
- Discharge the piezo actuators of the S-331 before installation:
Connect the S-331 to the switched-off PI controller, which is equipped with an internal discharge resistor.
- Do **not** pull the connector out of the electronics during operation.



Touching the contacts in the connector can lead to an electric shock (max. 120 V DC) and minor injuries.

- Do **not** touch the contacts in the connector.
- Use the screws to secure the connector of the S-331 against being pulled out of the controller.

NOTICE**Heating up of the S-331 during operation!**

The heat produced during operation of the S-331 can affect your application.

- Install the S-331 so that the application is not impaired by the dissipated heat.
- Ensure sufficient ventilation at the place of installation.
- Make sure that the complete bottom side of the S-331 is in contact with the surface on which the S-331 is mounted.

NOTICE**Destruction of the piezo actuator due to electric flashovers!**

Using the S-331 in environments that increase the electrical conductivity can lead to the destruction of the piezo actuator by electric flashovers. Electric flashovers can be caused by moisture, high humidity, liquids, and conductive materials (e.g., metal dust). In addition, electric flashovers can also occur in certain air pressure ranges due to the increased conductivity of the air.

- Avoid operating the S-331 in environments that can increase the electric conductivity.
- Only operate the S-331 within the permissible ambient conditions and classifications (p. 45).

NOTICE**Destruction of the piezo actuator due to short-circuiting without a discharge resistor!**

When a charged piezo actuator is short-circuited without a discharge resistor, this can lead to a contraction shock and thus to the destruction of the piezo ceramic.

- Only discharge the S-331 according to the instructions in "Discharging S-331" (p. 35).

NOTICE**Warping of the S-331 due to mounting on uneven surfaces!**

Mounting the S-331 on an uneven surface can warp the S-331. Warping reduces the accuracy.

- Mount the S-331 onto an even surface. The recommended flatness of the surface is $\leq 30 \mu\text{m}$.
- For applications with large temperature changes:
Only mount the S-331 on surfaces that have the same or similar thermal expansion properties as the S-331.

NOTICE**Damage due to unsuitable cables!**

Unsuitable cables can damage the S-331 and the electronics.

- Only use cables provided by PI for connecting the S-331 to the electronics.

5.2 Mounting the Mirror on the S-331

You have the following options for mounting the mirror on the motion platform of the S-331:

- Gluing the mirror
- Screw the mirror holder in

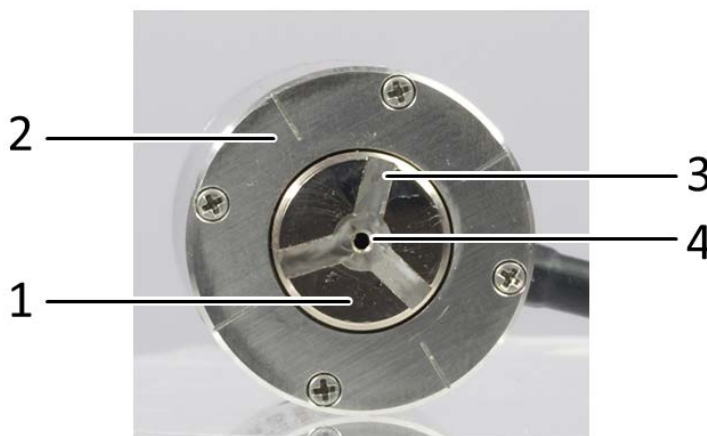

Figure 11: Top view of the S-331

- | | |
|---|--|
| 1 | Motion platform |
| 2 | Housing |
| 3 | Groove for gluing |
| 4 | M1.6 threaded hole with 3 mm depth for screwing a mirror holder in |

NOTICE**Impermissibly high forces and torques!**

Impermissibly high forces and torques that are applied to the motion platform can damage the S-331.

- Avoid high forces and torques on the motion platform when mounting the mirror.

NOTICE**Reduced positioning accuracy due to improper mounting!**

Improper mounting can reduce the positioning accuracy of the piezo tip/tilt platform.

- Avoid overtightening the mirror:
 - To glue the mirror, choose an adhesive that hardens at room temperature and contracts as little as possible during drying and hardening. Recommendation: Two-component adhesive made of epoxy resin that hardens in 24 hours at a temperature above 25 °C and is resistant to shearing forces.
 - In the case of applications with large temperature changes:
Make sure that the mirror and mirror holder have the same or similar thermal expansion properties as the motion platform of the S-331 (material of the platform: titanium).
- Make sure that there is no adhesive between the motion platform and the housing of the S-331 and in the hole in the middle of the platform; see figure above.

INFORMATION

If the mirror is to be interchangeable, it is recommended to mount it with a mirror holder.

- Take the moment of inertia of the mirror holder into account when calculating the resonant frequency of the piezo tip/tilt platform (p. 19).

INFORMATION

Recommended characteristics of the mirror:

- Diameter: 12.7 mm (0.5")
- Thickness: 3 mm
- Material: Glass, e.g., borosilicate crown glass (BK7), whose moment of inertia matches the application (details see "Dynamic Behavior" (p. 15)) and whose thermal expansion coefficient is almost the same as titanium.



Figure 12: The three-arm groove (colored white here) on the motion platform is used for punctiform application of the adhesive.

INFORMATION

For gluing the mirror, it is recommended to use a suitable centering aid; for an example, see below. Suitable centering aids are available as accessories (p. 11).

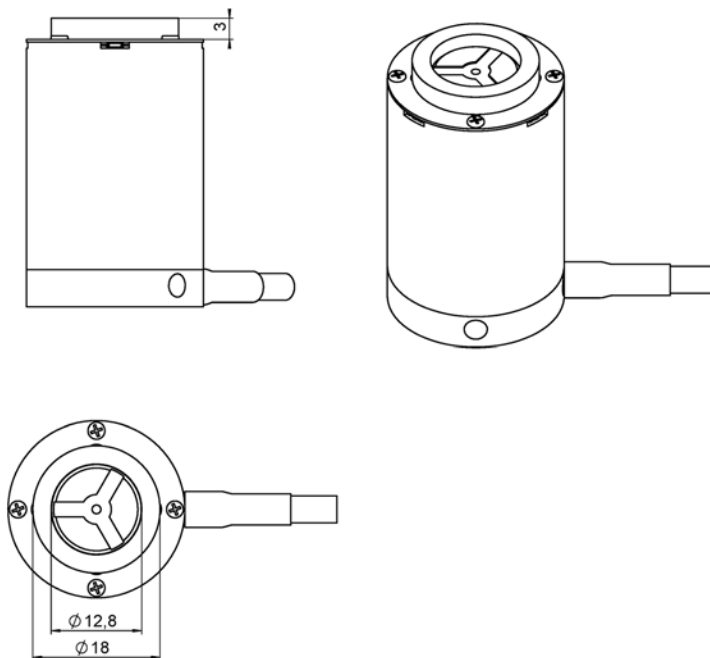

Figure 13: Example: S-331 with centering aid for a mirror with a thickness of 3 mm and \varnothing 12.7 mm

Requirements

- ✓ You have read and understood the general notes on installation (p. 23).
- ✓ The S-331 is **not** connected to the electronics.

Tools and accessories

- Suitable mirror, see above and "Dynamic Behavior" (p. 15)
- When the mirror is glued to the platform:
 - Suitable adhesive, see above
 - Option: Suitable centering aid
 - Cotton swab
 - Isopropyl alcohol
- If the mirror is mounted with a mirror holder:
 - Suitable mirror holder with threaded pin or M1.6 screw
- Powder-free gloves

Gluing the mirror to the S-331

1. Option: Align the centering aid on the motion platform of the S-331 carefully and fix it appropriately.
2. Apply a small amount of adhesive to three points in the three-armed groove of the motion platform; see above figure. Only apply a pinhead-sized amount to each point
3. Carefully place the mirror into the centering aid on the motion platform. Avoid touching the mirror surface.
4. Carefully and briefly press the mirror onto the motion platform with a cotton swab.
5. If necessary, remove the adhesive residue with a cotton swab and isopropyl alcohol.
6. Allow the adhesive to harden according to the instructions of the adhesive manufacturer.
7. Remove the centering aid.

Affix the mirror holder to the S-331

- Mount the mirror holder via the M1.6 threaded hole on the motion platform.
Maximum torque: 0.2 Nm
Maximum screw-in depth: 3 mm
- Affix the mirror to the mirror holder appropriately.

5.3 Mounting the S-331

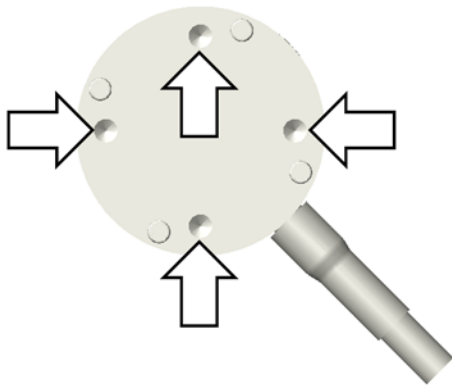

Figure 14: M3 holes of the S-331 for mounting on a surface

Requirements

- ✓ You have read and understood the general notes on installation (p. 23).
- ✓ The S-331 is **not** connected to the electronics.
- ✓ You have accounted for the space required to route cables without bending and according to regulations.

Tools and accessories

- For the dimensions of the S-331 and the position and depth of the M3 holes, see "Dimensions" (p. 47).
- You have provided a suitable surface:
 - Four through-holes for M3 screws are provided.
 - The evenness of the surface is $\leq 30 \mu\text{m}$.
- 4 M3 screws of suitable length (p. 47)
- Suitable tools

Mounting the S-331 on a surface

1. Align the S-331 on the surface so that the M3 holes in the S-331 and the surface overlap.
2. Insert the four screws through the holes in the surface into the base body of the S-331 from below.
3. Tighten the four screws.
 - Maximum screw-in depth: 4 mm
 - Maximum torque: 1.1 Nm
4. Check that the S-331 is affixed firmly.

5.4 Connecting the S-331 to the Protective Earth Conductor

INFORMATION

- Observe the applicable standards for connecting the protective earth conductor.

The S-331 has an M4 hole for mounting the protective earth conductor. This hole is marked with the symbol for the protective earth conductor ⚡ (see "Dimensions" (p. 47)).

Requirements

- ✓ You have read and understood the general notes on installation (p. 23).
- ✓ The S-331 is **not** connected to the electronics.

Tools and accessories

- Suitable protective earth conductor: Cross-sectional area of the cable $\geq 0.75 \text{ mm}^2$
- Supplied M4 protective earth screw set (p. 11) for connecting the protective earth conductor
- Suitable screwdriver

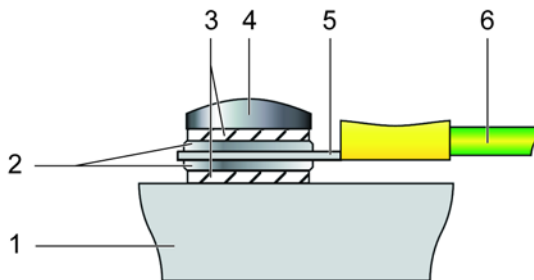

Figure 15: Connecting the protective earth conductor (profile view)

- 1 Base body of the S-331
- 2 Flat washer
- 3 Safety washer
- 4 Screw
- 5 Cable lug
- 6 Protective earth conductor

Connecting the S-331 to the protective earth conductor

1. If necessary, attach a suitable cable lug to the protective earth conductor.
2. Use the M4 screw (together with the washers and self-locking washers) to affix the cable lug of the protective earth conductor to the protective earth connection of the S-331 as shown in the profile view.
3. Tighten the M4 screw with a torque of 1.2 Nm to 1.5 Nm.
4. Make sure that the contact resistance at all connection points relevant for connecting the protective earth conductor is $<0.1 \Omega$ at 25 A.

5.5 Connecting the S-331 to the Controller**INFORMATION**

Systems consisting of an S-331 and controller are calibrated at the factory to achieve optimum performance.

- Note the assignment of the axes to the controller channels, which is specified on the calibration label of the piezo servo controller.

Requirements

- ✓ You have read and understood the general notes on installation (p. 23).
- ✓ You have installed a suitable controller (p. 13).
- ✓ You have read and understood the user manual of the controller.
- ✓ The controller is switched off.

Connecting the S-331.xSH to the E-727.3SD controller

1. Plug the connector of the S-331.xSH into the corresponding socket of the controller (see user manual of the controller).
2. Use the integrated screws to secure the connection against accidental disconnection.

Connecting the S-331.xSL to E-50x modules

1. Connect the piezo connectors of the S-331.xSL with the piezo amplifier modules as follows.

If you use an E-503.00S module:

- **PZT1** to **PZT** for channel 1 (**CH1**)
- **PZT2** to **PZT** for channel 2 (**CH2**)
- **PZT 100V** to **PZT** for channel 3 (**CH3**)

If you use two E-505.00 modules for variable voltages and an E-505.00S module for 100 V fixed voltage:

- **PZT1** to **PZT** of an E-505.00 module
 - **PZT2** to **PZT** of the second E-505.00 module
 - **PZT 100V** to **PZT** of the E-505.00S module
2. Connect the sensor connections of the S-331.xSL to the E-509.S3 servo controller module as follows:
- **AXIS 1** to **SENSOR** for channel 1 (**SERVO 1**)
 - **AXIS 2** to **SENSOR** for channel 2 (**SERVO 2**)

6 Startup and Operation

In this Chapter

General Notes on Startup and Operation.....	33
Operating the S-331.....	35
Discharging the S-331	35

6.1 General Notes on Startup and Operation

CAUTION



Risk of electric shock if the protective earth conductor is not connected!

If a protective earth conductor is not or not properly connected, dangerous touch voltages can occur on the S-331 in the case of malfunction or failure of the system. If touch voltages exist, touching the S-331 can result in minor injuries from electric shock.

- Before startup, establish contact between the S-331 and the protective earth conductor.
- Do **not** remove the protective earth conductor during operation.
- Make sure that the contact resistance at all connection points relevant for mounting the protective earth conductor is $<0.1 \Omega$ at 25 A.
- If the protective earth conductor has to be temporarily removed (e.g., for modifications), reconnect the S-331 to the protective earth conductor before starting it up again.

NOTICE



Destruction of the piezo actuator due to electric flashovers!

Using the S-331 in environments that increase the electrical conductivity can lead to the destruction of the piezo actuator by electric flashovers. Electric flashovers can be caused by moisture, high humidity, liquids, and conductive materials (e.g., metal dust). In addition, electric flashovers can also occur in certain air pressure ranges due to the increased conductivity of the air.

- Avoid operating the S-331 in environments that can increase the electric conductivity.
- Only operate the S-331 within the permissible ambient conditions and classifications (p. 45).

NOTICE**Reduced lifetime of the piezo actuator due to permanently high voltage!**

The permanent application of a high static voltage to piezo actuators leads to a considerable reduction in the lifetime of the piezo ceramic.

- When the S-331 is not used but the electronics remain switched on to ensure temperature stability, discharge the S-331 (p. 35).

INFORMATION

Systems consisting of an S-331 and controller are set at the factory so that optimum performance can be achieved when a mirror with the recommended characteristics is glued onto the S-331 (p. 25).

- Only adjust the notch filter and the servo-control parameters of the controller when the moved mass and therefore the resonant frequency of the S-331 changes considerably.
Possible reasons:
 - The used mirror strongly deviates from the recommended characteristics (p. 25).
 - A mirror holder is used.

Only after replacing system components and only for models with LEMO connectors:

- Perform a recalibration of the axis displacement (see controller manual) or contact our customer service department (p. 41).
- Adjust the notch filter and servo-control parameters of the controller (see controller manual).

INFORMATION

Depending on the amplitude and frequency of the piezo voltage, the S-331 heats up during operation.

- Select the amplitude and frequency of the piezo voltage so that the maximum permissible operating temperature of the S-331 is not exceeded. For details, see "Recommended Control Signals for Dynamic Operation" (p. 46).

INFORMATION

Sound and vibration (e.g., footfall, knocks) can be transmitted to the S-331 and can affect its performance with regard to position stability.

- Avoid sound and vibration while the S-331 is being operated.

INFORMATION

The expansion of the piezo actuators depends on the ambient temperature and can vary by up to 10 % in the given temperature ranges (p. 45).

6.2 Operating the S-331

Requirements

- ✓ You have read and understood the general notes on startup and operation (p. 33).
- ✓ You have read and understood the user manual of the controller.
- ✓ You have properly installed the S-331 (p. 23).
- ✓ The controller and the required PC software have been installed. All connections with the controller have been established (see user manual of the controller).

Operating the S-331

- Follow the instructions in the manual for the controller (p. 13) used for startup and operation of the S-331.

6.3 Discharging the S-331

The S-331 must be discharged in the following cases:

- Before installation
- If the S-331 is not used and the controller remains switched on to ensure temperature stability
- Before demounting (e.g., before cleaning and transporting the S-331 and for modifications)

The S-331 is discharged via the internal discharge resistor of the controller from PI.

Discharging an S-331 that is connected to the controller

In closed-loop operation:

1. Switch off the servo mode on the controller.
2. Set the piezo voltage to 0 V on the controller.

In open-loop operation:

- Set the piezo voltage to 0 V on the controller.

Discharging an S-331 that is not connected to the controller

- Connect the S-331 to the switched-off controller from PI.

7 Maintenance

In this Chapter

General Notes on Maintenance.....	37
Cleaning the S-331	37

7.1 General Notes on Maintenance

NOTICE



Misalignment due to loosening screws!

The S-331 is maintenance-free and achieves its positioning accuracy as a result of the optimum alignment of mechanical components and piezo actuators. Loosened screws cause a loss in positioning accuracy.

- Only loosen screws according to the instructions in this manual.
- Do **not** open the S-331.

7.2 Cleaning the S-331

Requirements

- ✓ You have discharged the piezo actuators of the S-331 (p. 35).
- ✓ You have disconnected the S-331 from the controller.

Cleaning the S-331

- Clean the surfaces of the S-331 with a cloth dampened with a mild cleanser or disinfectant (e.g., isopropyl alcohol).
- Do **not** do any ultrasonic cleaning.

8 Troubleshooting

Problem	Possible causes	Solution
No or uncontrolled motion	<ul style="list-style-type: none"> ▪ Cable not connected correctly ▪ Controller defective ▪ Cable defective ▪ Piezo ceramic defective after electric flashover 	<ul style="list-style-type: none"> ➤ Check the cable connections (p. 31). ➤ Contact our customer service department (p. 41).
Reduced accuracy	Warped base body	<p>Only mount the S-331 on surfaces with the following characteristics:</p> <ul style="list-style-type: none"> ▪ Evenness of at least 30 μm ▪ The thermal expansion properties are similar to those of the S-331 (e.g., surfaces made of steel)
	Adhesive has run into the M1.6 threaded hole or between the platform and the housing of the S-331	<ul style="list-style-type: none"> ➤ Contact our customer service department (p. 41).
	S-331 or controller has been replaced	<p>After the S-331 or controller has been replaced, it is necessary to recalibrate the axis displacement.</p> <ul style="list-style-type: none"> ➤ Perform a recalibration of the axis displacement (see controller manual) or contact our customer service department (p. 41).
	Mirror with mirror holder have been replaced	<p>The change in the mass that has to be moved by the S-331 influences the dynamic characteristics such as the resonant frequency of the piezo tip/tilt platform.</p> <ul style="list-style-type: none"> ➤ Adjust the notch filter and servo-control parameters of the controller; see controller manual.
	Operating temperature outside of the permissible range (p. 43)	<ul style="list-style-type: none"> ➤ Contact our customer service department (p. 41).

If the problem that occurred with your system is not listed in the table above or cannot be solved as described, contact our customer service department (p. 41).

9 Customer Service

For inquiries and orders, contact your PI sales engineer or send us an email (service@pi.de).

- If you have questions concerning your system, have the following information ready:
 - Product and serial numbers of all products in the system
 - Firmware version of the controller (if available)
 - Version of the driver or the software (if available)
 - Operating system on the PC (if available)
- If possible: Take photographs or make videos of your system that can be sent to our customer service department if requested.

The latest versions of the user manuals are available for download (p. 3) on our website.

10 Technical Data

In this Chapter

Specifications	43
Dimensions	47
Pin Assignment	49

10.1 Specifications

10.1.1 Data Table

	S-331.2SL / S-331.2SH	S-331.5SL / S-331.5SH	Unit	Tolerance
Active axes	θ_x, θ_y	θ_x, θ_y		
Motion and positioning				
Integrated sensor	SGS	SGS		
Tip/tilt angle in θ_x, θ_y at -20 to 120 V, open loop	4.2	7	mrad	min.
Tip/tilt angle in θ_x, θ_y , closed loop	3	5	mrad	
Resolution in θ_x, θ_y , open loop	0.05	0.1	μ rad	typ.
Resolution in θ_x, θ_y , closed loop	0.1	0.25	μ rad	typ.
Linearity error in θ_x, θ_y	0.3 ⁽¹⁾ 0.1 ⁽²⁾	0.3 ⁽¹⁾ 0.1 ⁽²⁾	%	typ.
Repeatability in θ_x, θ_y , 10 % tip/tilt angle	0.3	0.5	μ rad	typ.
Repeatability in θ_x, θ_y , 100 % tip/tilt angle	3	5	μ rad	typ.
Mechanical properties				
Resonant frequency, no load, in θ_x, θ_y	12	16	kHz	± 20 %
Resonant frequency, under load in θ_x, θ_y (with glass mirror, \varnothing 12.7 mm, thickness 3 mm)	9	10	kHz	± 20 %
Distance of pivot point to platform surface	4	4	mm	± 1 mm
Platform moment of inertia	30	30	$g \times mm^2$	± 20 %

	S-331.2SL / S-331.2SH	S-331.5SL / S-331.5SH	Unit	Tolerance
Drive properties				
Ceramic type	PICMA®	PICMA®		
Electrical capacitance	0.96 / axis	6.2 / axis	μF	±20 %
Miscellaneous				
ID chip functionality	S-331.2SH	S-331.5SH		
Operating temperature range	-20 to 80	-20 to 80	°C	
Material housing	Steel	Steel		
Platform material	Titanium	Titanium		
Mass	0.13	0.28	kg	±5 %
Cable length	2	2	m	+100 mm / -0 mm
Sensor/voltage connection	SH version: Sub-D 37 (m) SL version: LEMO	SH version: Sub-D 37 (m) SL version: LEMO		
Recommended electronics	E-503, E-727	E-503, E-727		

(1) S-331.xSL in conjunction with E-5xx analog controller modules.



(2) S-331.xSH in conjunction with digital controllers, unidirectional.

The resolution of the system is limited only by the noise of the amplifier and the measuring technology because PI piezo nanopositioning systems are free of friction.

All specifications based on room temperature (22 °C ±3 °C).

10.1.2 Maximum Ratings

The models of the S-331 are designed for the following operating data:

Model	Maximum operating voltage 	Maximum operating frequency ¹ (without load, at 100 V _{pp}) 	Maximum power consumption ² 
S-331.2SH S-331.2SL	-20 to +120 V	1.75 kHz	21 W/axis
S-331.5SH S-331.5SL	-20 to +120 V	1.5 kHz	25 W/axis

¹ To ensure stable operation, the maximum operating frequency has been defined as around one third of the mechanical resonant frequency. To calculate the resonant frequency of the system of S-331 and mirror, see "Dynamic Behavior" (p. 15).

² The heat that is generated by the piezo actuator during dynamic operation limits the value for maximum power consumption.

Details can be found at the following website:

<http://piceramic.com/piezo-technology/properties-piezo-actuators/electrical-operation.html>

10.1.3 Ambient Conditions and Classifications

The following ambient conditions and classifications for the S-331 must be observed:

Area of application	For indoor use only
Maximum altitude	2000 m
Air pressure	1100 hPa to 0.1 hPa
Relative humidity	Highest relative humidity 80 % for temperatures up to 31 °C Decreasing linearly to 50 % relative humidity at 40 °C
Storage temperature	-20 °C to 80 °C
Transport temperature	-25 °C to 85 °C
Overvoltage category	II
Protection class	I
Degree of pollution	1
Degree of protection according to IEC 60529	IP20

10.1.4 Recommended Control Signals for Dynamic Operation

The maximum permissible operating temperature for the piezo actuators of the S-331 is 80 °C. During dynamic continuous operation of a single axis, this temperature value is achieved at an ambient temperature of approx. 20 °C for the following characteristics of a sinusoidal piezo voltage signal and then remains constant.

Model	Amplitude	Operating frequency
S-331.2SH	20 V _{pp}	2500 Hz
S-331.2SL	50 V _{pp}	2000 Hz
	100 V _{pp}	500 Hz
S-331.5SH	20 V _{pp}	2000 Hz
S-331.5SL	50 V _{pp}	700 Hz
	100 V _{pp}	150 Hz

At a higher ambient temperature and when both axes are operated, the maximum permissible operating temperature can already be achieved at a lower amplitude and/or lower operating frequency.

10.2 Dimensions

Dimensions in mm. Note that the decimal places are separated by a comma in the drawings.

10.2.1 S-331

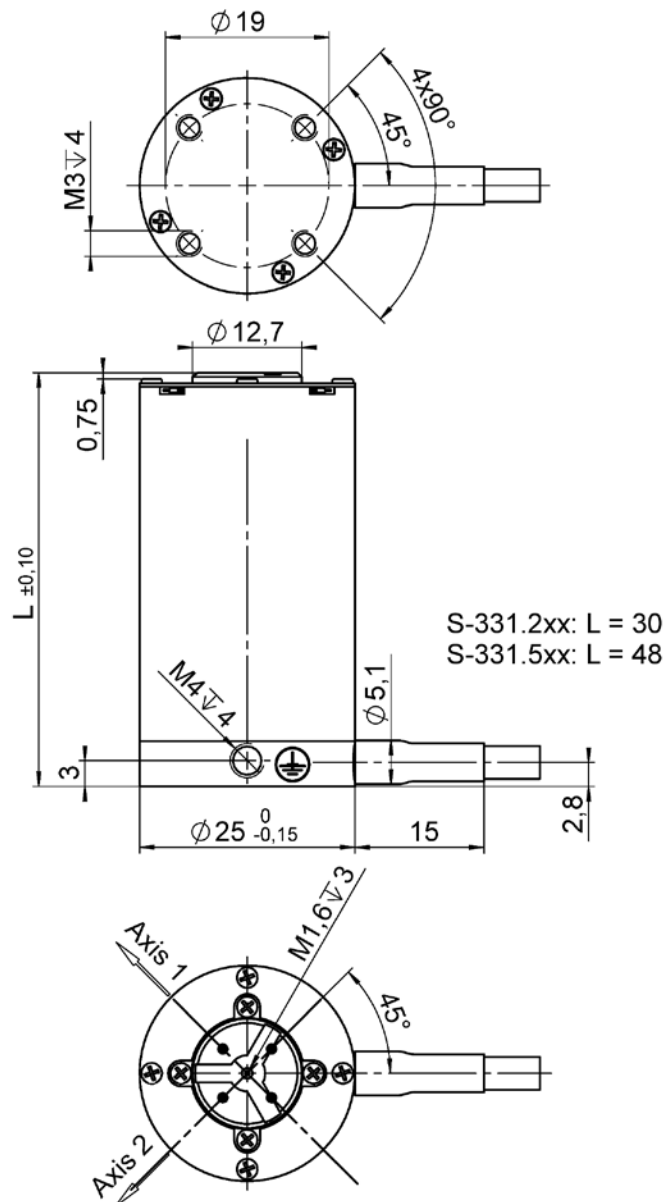

Figure 16: S-331.xSH

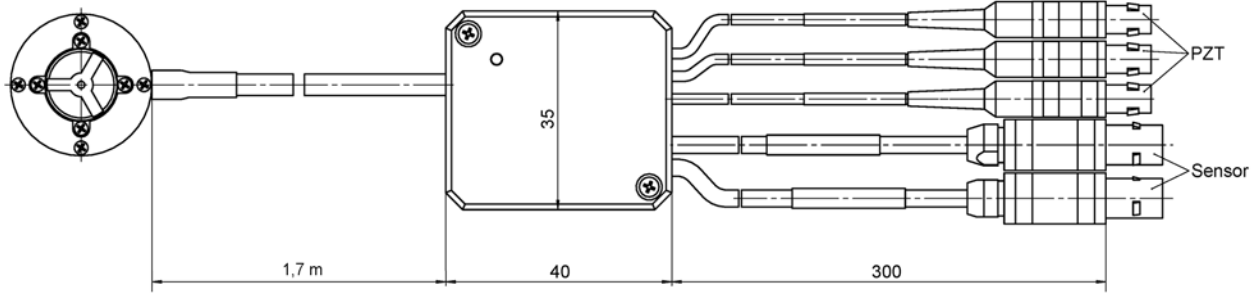

Figure 17: S-331.xSL: Position and dimensions of the cable splitter box

10.2.2 S-330.Xx

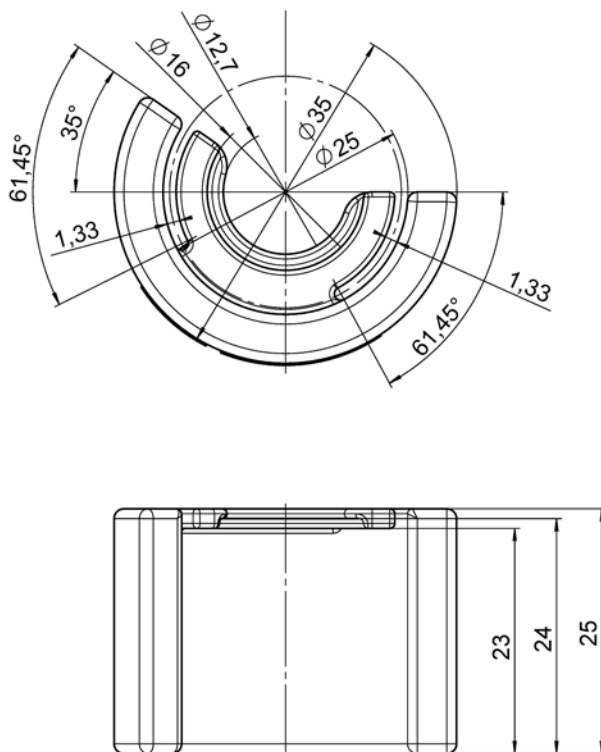

Figure 18: S-330.X1

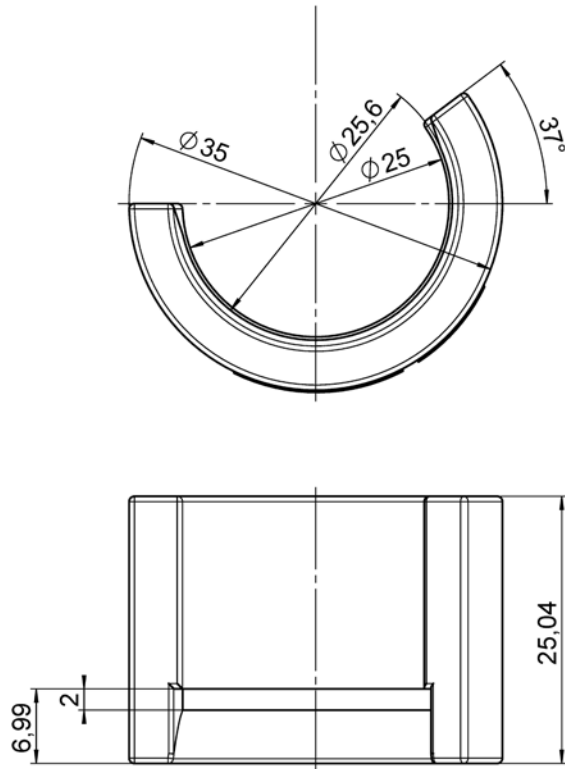

Figure 19: S-330.X2

10.3 Pin Assignment

10.3.1 S-331.xSH: Sub-D 37 (m) Piezo and Sensor Connection



Figure 20: Sub-D 37 (m) piezo and sensor connection

Pin	Signal*	Function
1	-	-
2	GND	Ground
3	ID chip CH2	Data, ID chip axis 2
4	-	-

Pin	Signal*	Function
5	ID chip GND	Ground, ID chip
6	-	-
7	GND	Ground
8	-	-
9	GND	Ground
10	SGS CH2+	SGS signal axis 2 (positive)
11	GND	Ground
12	CH1+ SGS	SGS signal axis 1 (positive)
13	GND	-
14	Reserved	Reserved
15	Reserved	Reserved
16	Piezo CH1+	Piezo voltage, axis 1 (positive)
17	Piezo CH2+	Piezo voltage, axis 2 (positive)
18	Piezo CH3+	100 V fixed voltage
19	-	-
20	-	-
21	ID chip CH1	Data, ID chip axis 1
22	ID chip GND	Ground, ID chip
23 to 27	-	-
28	SGS CH2-	SGS signal axis 2 (negative)
29	SGS CH2 Ref	SGS reference axis 2
30	SGS CH1-	SGS signal axis 1 (negative)
31	SGS CH1 Ref	SGS reference axis 1
32	Reserved	Reserved
33	Reserved	Reserved
34	Piezo CH1-	Piezo voltage, axis 1 (negative)
35	Piezo CH2-	Piezo voltage, axis 2 (negative)
36	Piezo CH3-	Ground 100 V fixed voltage
37	-	-

* The "-" sign indicates that the corresponding pin has not been assigned.

10.3.2 S-331.xSL: LEMO Piezo and Sensor Connections



Figure 21: Sensor connection: LEMO connector FFA.0S.304.CLAC32Y, contact side

Pin	Signal	Function
1	SGS Ref	SGS reference
2	SGS-	SGS signal (negative)
3	SGS+	SGS signal (positive)
4	SGS GND	Ground SGS signal

PZT

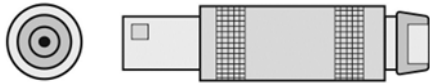

Figure 22: Piezo connector

Signal	Function	Connector Shell
PZT	Piezo Voltage	Ground

11 Old Equipment Disposal

In accordance with EU law, electrical and electronic equipment may not be disposed of in EU member states via the municipal residual waste.

Dispose of your old equipment according to international, national, and local rules and regulations.

In order to fulfil its responsibility as the product manufacturer, Physik Instrumente (PI) GmbH & Co. KG undertakes environmentally correct disposal of all old PI equipment made available on the market after 13 August 2005 without charge.

Any old PI equipment can be sent free of charge to the following address:

Physik Instrumente (PI) GmbH & Co. KG
Auf der Roemerstr. 1
D-76228 Karlsruhe, Germany



12 EU Declaration of Conformity

For the S-331, an EU Declaration of Conformity has been issued in accordance with the following European directives:

Low Voltage Directive

EMC Directive

RoHS Directive

The applied standards certifying the conformity are listed below.

Safety (Low Voltage Directive): EN 61010-1

EMC: EN 61326-1

RoHS: EN 50581

