

Order no.	6540-9-	0	
DC-B-070		1	]
2Phase-020		2	
without AE-060		0	
AE-060, angular scale		1	

WT-85 Goniometer  
Order no. 6540-9-

User Manual  
Version: **00.000**

Date: 11.08.2016

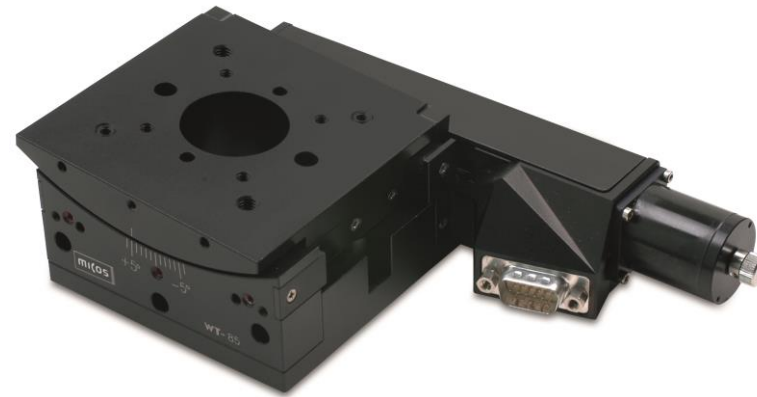

© 2015 PI miCos GmbH, Eschbach, Germany. The text, photographs and drawings in this manual are protected by copyright. With regard thereto, PI miCos GmbH retains all rights. The use of any text, images and drawings is permitted only in part and only when indicating the source.

Subject to change without notice. This manual is superseded by any new release. The latest release is available for download (<http://www.pimicos.com>).

## CONTENTS

### 1. ABOUT THIS DOCUMENT

- 1.1 Objective and Target Group of this User Manual
- 1.2 Symbols and Typographic Conventions
- 1.3 Other Applicable Documents

### 2. SAFETY

- 2.1 Intended Use
- 2.2 General Safety Instructions
  - 2.2.1 Organizational Measures
  - 2.2.2 Measures during Installation
  - 2.2.3 Measures during Start-Up
  - 2.2.4 Measures during Operation
  - 2.2.5 Measures during Maintenance

### 3. UNPACKING

### 4. PRODUCT DESCRIPTION

- 4.1 Features and Application Area
- 4.2 Model Overview
- 4.3 Product View
- 4.4 Safety Instructions
- 4.5 Scope of Delivery
- 4.6 Optional Accessories

### 4.7 Technical Features

- 4.7.1 Load Capacity Data
- 4.7.2 Motors
- 4.7.3 Measuring System
- 4.7.4 Limit Switch
- 4.7.5 Connector
- 4.7.6 Technical Data

### 4.8 Ambient Conditions

### 5. INSTALLATION

- 5.1 General Notes on Installation
- 5.2 Mounting the goniometer
- 5.3 Mounting the Load

### 6. START-UP

- 6.1 General Notes on Start-Up

### 7. MAINTENANCE

### 8. TROUBLESHOOTING

### 9. CUSTOMER SERVICE

### 10. OLD EQUIPMENT DISPOSAL

### 11. EU DECLARATION OF CONFORMITY

### 1. ABOUT THIS DOCUMENT

All specifications in this user manual refer only to the standard products that are included in the PI miCos catalog. Any special features that are different, in particular special requests from customers, are supplied with the user manual as additional documentation in the form of "Technical Notes".

#### 1.1 Objective and Target Group of this User Manual

- This user manual contains all information required for the intended use of the WT-85.
- Basic knowledge on servo systems, motion control concepts and applicable safety measures is assumed.
- The latest version of the user manual and answers to any questions can be obtained from our customer service department (see chapter 9)

#### 1.2 Symbols and Typographic Conventions

The symbols and typographic conventions used in this manual have the following meanings:

---

 NOTICE

---

 Dangerous situation!  
If not avoided, the dangerous situation will result in death, injuries or damage to the equipment  
-> Actions to take to avoid the situation

---

---

 NOTICE

---

 Information for easier handling, tricks, tips, etc.

---

#### 1.3 Other Applicable Documents

All products and programs from PI miCos mentioned in this documentation are described in separate user manuals.

The latest versions of the user manuals can be obtained from our customer service department (see chapter 9).

### 2. SAFETY

#### 2.1 Intended Use

The WT-85 is a laboratory device as defined by DIN EN 61010. It is intended for indoor use and use in an environment that is free of dirt, oil, and lubricants.

In accordance with its design, the WT-85 is intended for single-axis positioning, adjusting and rotation of loads around an axis at various velocities. The WT-85 can be mounted horizontally or vertically.

The intended use of the WT-85 is only possible in conjunction with suitable electronics. The following options are available:

1. Drive electronics and controller with suitable software
2. Combination device with suitable software

- The electronics are not included in the scope of delivery of the WT-85.
- The electronics must provide the required voltages. To ensure proper performance of the servo-control system, the electronics must be able to read out and further process the signals from the reference switch as well as those from the incremental position encoder.

## 2.2 General Safety Instructions

The WT-85 is built according to state-of-the-art technology and recognized safety standards. Improper use of the WT-85 may result in personal injury and/or damage to the E-85.

1. Only use the WT-85 for its intended purpose, and only use it if it is in good working order.
2. Read the user manual.
3. Immediately eliminate any faults and malfunctions that are likely to affect safety.

The operator is responsible for the correct installation and operation of the WT-85.

### 2.2.1 Organizational Measures

#### User Manual

- Always keep this user manual available when using the WT-85. If the user manual is lost or damaged, contact our customer service department (see chapter 10).
- Add all information from the manufacturer such as supplements or technical notes to the user manual.
- Only use the device on the basis of the complete user manual. If your user manual is incomplete and is therefore missing important information, serious or fatal injury as well as damage to the equipment can result.
- Only install and operate the WT-85 after you have read and understood this user manual.

#### Personnel Qualification

The WT-85 may only be started up, operated, maintained and cleaned by authorized and appropriately qualified personnel.

### 2.2.2 Measures during Installation

The WT-85 may be damaged by excessively long screws and wrongly mounted parts.

- Only use screws of the correct length for the respective mounting holes.
- Only mount the WT-85 and the loads on the mounting fixtures (holes) intended for this purpose.
- The WT-85 heats up during operation. High temperatures can influence your application.
- Install the WT-85 so that your application is not affected by the dissipating heat.
- Cable extensions can affect the performance of the WT-85 and damage the electronics.
- Only use genuine PI miCos parts to connect the WT-85 to the electronic equipment.
- Do not use cable extensions. If you need longer cables, use cable extensions from PI miCos.
- Avoid short circuiting the lines for motor voltages since this can damage the electronics.

### 2.2.3 Measures during Start-Up

Do not put your WT-85 into operation until it is fully mounted and connected.

Your system can be damaged by uncontrolled oscillation of the WT-85. Noise generated during operation of the WT-85 is a typical sign of oscillation.

- Immediately switch off the servo-control system of the affected rotational axis.
- Check the settings of the servo-control parameters.

Moving parts attached to devices with goniometers can accelerate rapidly and generate high forces which can cause injury or damage to equipment.

Unintentional motion of the goniometer is possible when it is connected to the controller for the first time. Defective software or incorrect operation of the software can also result in unintentional motions.

Do not place any objects in areas where they can be caught by moving parts.

Set the control signal so that the moving part does not stop abruptly or try to continue motion.

- Determine the maximum velocity for your application.

### 2.2.4 Measures during Operation

- If noise occurs during operation of the WT-85, check the settings of the servo-control parameters of your controller.
- During continuous operation at room temperature, do not exceed a maximum of 90 % of the control signal level.
- For continuous operation at other temperatures, observe the maximum permissible duty cycle in relation to the ambient temperature or contact our customer service department for more information (see chapter 9).

### 2.2.5 Measures during Maintenance

The WT-85 is precision adjusted.

- Do not loosen any sealed screws.

Dirt, oil, lubricants and condensation will render the motor/drive inoperable.

- Keep the motor of the WT-85 free from lubricants.
- Keep the WT-85 free of dirt and condensation.

### 3. UNPACKING

1. Unpack the WT-85 with care.
2. Compare the contents with the items listed in the contract and the packing list.
3. Inspect the contents for signs of damage. If there is any sign of damage or missing parts, contact PI miCos immediately.
4. Keep all packaging materials in case the product needs to be returned.

**! WARNING**



Risk of suffocation for children. Keep the packaging foil away from children.  
 Dispose of packaging materials according to environmental regulations.

**! NOTICE**



All specifications in this user manual refer only to the standard products that are included in the PI miCos catalog. Any special features that are different, in particular special requests from customers, are supplied with the user manual as additional documentation in the form of "Technical Notes".

### 4. PRODUCT DESCRIPTION

#### 4.1 Features and Application Area

Our products are designed specifically for use in the laboratory.

#### 4.2 Model Overview

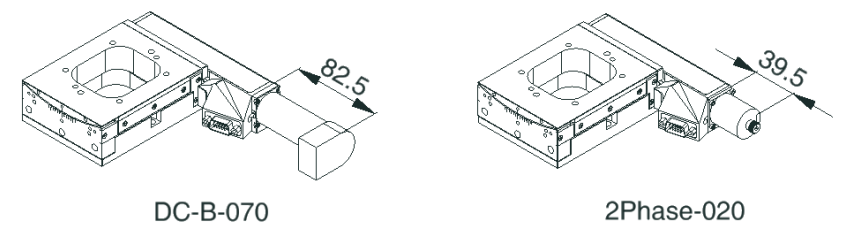

Order no.	6540-9-	0	
DC-B-070		1	}
2Phase-020		2	
without AE-060		0	
AE-060, angular scale		1	

#### 4.3 Product View

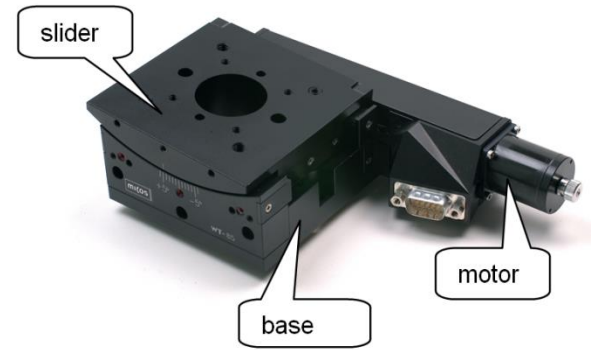

## 8 WT-85 Goniometer

### 4.4 Safety Instructions

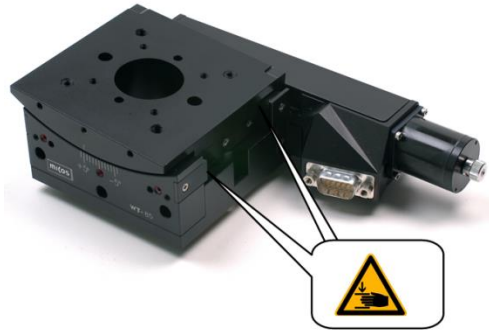

#### NOTICE



Protect the product against mechanical damage (knocking, shock, ...).  
 Never start up an axis if you suspect it to be damaged or broken.  
 Do not disconnect or connect connectors when voltage is present.

#### WARNING



Risk of catching by rotating parts such as couplers and ball screws

#### WARNING



It is recommended that all persons entrusted with working with this product and who therefore come into contact with areas marked by the ESD warning symbol, are given training and a comprehensive explanation of the ESD warning symbol with respect to the ESD precautions.

### 4.5 Scope of Delivery

- Goniometer according to order.
- Mounting accessories (screws & pins) in fast-sealing bag.

### 4.6 Optional Accessories

Obtain more information on optional accessories from our customer service department (chapter 9).

### 4.7 Technical Features

#### 4.7.1 Load Capacity Data

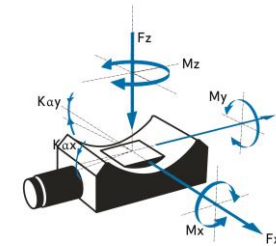

#### FACTS

Load characteristics	Fx(N)	Fy(N)	Fz(N)	Mx(Nm)	My(Nm)	Mz(Nm)	kax(μrad/Nm)	kay(μrad/Nm)
DC-B-070	15	15	20	0.75	4	4	80	80
2Phase-020	15	15	20	0.75	4	4	80	80



4.7.2 Motors

**DC-B-070**

Motor type		DC brush RE-026
Nominal voltage	V	36
Max. continuous current	A	0.931
Electrical resistance	$\Omega$	5.68
Electrical inductance	mH	0.430
Torque constant	mNm/A	36.3
Velocity constant	rpm/V	263
n/M slope curve	rpm/mNm	41.2
no load velocity at 36 V	rpm	9400
Max. continuous velocity at nominal torque	rpm	
Inertia	kgm <sup>2</sup>	1.2.0E-6
Continuous torque	mNm	33.8
Rotary encoder		<b>RE-010</b> RS422 2-channel + index
Encoder increments (quad counts)	n	2000

**RE-010**

Rotary optical encoder RS-422 quadrature

Encoder type		HEDL rotary optical encoder
Quadrature counts per revolution	n	2000
Signal output		RS-422
Channels		2 + index
Supply voltage	VDC	4.5..5.5
Current consumption, typical (Vcc = 5 V DC)	mA	57
Frequency range	KHz	100
Code disc inertia	kg m <sup>2</sup>	0.5E-7
Operating temperature	°C	-40..100

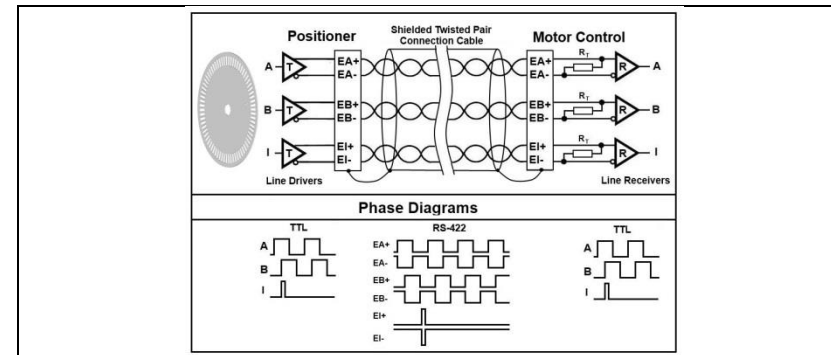

**2Phase-020**

Motor type		2-phase bipolar ZSS-25-200-1.2E
Phase current	A	1.2
Step angle	°	1.8 °
Steps	n	200
Coil resistance	$\Omega$	0.95
Coil inductance	mH	0.4
Holding torque	mNm	13
Inertia	kgm <sup>2</sup>	0.25 E-6
weight	kg	0.07

4.7.3 Measuring System

AE-060 WT-85

Angular optical encoder RS-422 quadrature

Encoder type		Angular incremental RGH-24
Quadrature counts per 360°	n	2980132
Resolution	deg	0.0001208
Grating period	µm	20
Grating material		Steel
Interpolator	n	Integrated 25 times
Signal output		RS-422 quadrature
Channels		2+1 index
Supply voltage	VDC	5 +/- 10%
Current consumption, typical (Vcc = 5 V DC)	mA	<150
Frequency range, Counter capability	MHz	1
Operating temperature	°C	0..55
Absolute accuracy	deg	<+/- 0.01
Index	deg	middle of travel
Connector		Sub-D (m), 9-pin

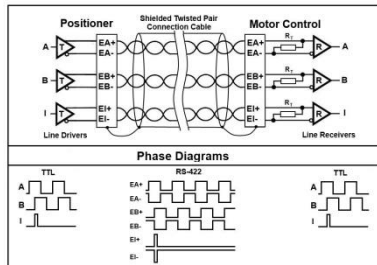

4.7.4 Limit Switch

Mechanical limit switch

Max. voltage (resistive load)	V	30
Max. current (resistive load)	A	1
Contact type		Normal closed
Max. switch voltage (resistive load)	VDC	3-24
Operations		>5x10 <sup>4</sup>
Operating temperature	°C	-40 to +85

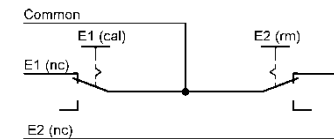

4.7.5 Connector

**ST-050**

DC motor, HD Sub-D (m), 15-pin assignment with mechanical limit switch

HD Sub-D (m), 15-pin	Function	
1	EA+	Encoder channel A+
2	EB+	Encoder channel B+
3	EC+	Encoder channel I+
4	EGND	Supply encoder GND
5	nc	
6	EA-	Encoder channel A-
7	EB-	Encoder channel B-
8	EC-	Encoder channel I-
9	E5V	Encoder supply voltage
10	nc	
11	M+	DC brush motor +
12	M-	DC brush motor -
13	LE2	Limit forward
14	LE1	Limit reverse
15	LCOM	Limit common

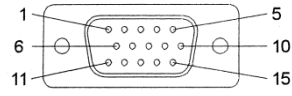

**ST-010**

2SM motor, HD Sub-D (m), 15-pin assignment with mechanical limit switch

HD Sub-D (m), 15-pin	Function	
1	MA+	Motor phase A+
2	MA-	Motor phase A-
3	nc	
4	nc	
5	MB+	Motor phase B+
6	MB-	Motor phase B-
7	nc	
8	nc	

9	nc	
10	nc	
11	nc	
12	nc	
13	LE2	Limit forward
14	LE1	Limit reverse
15	LCOM	Limit common

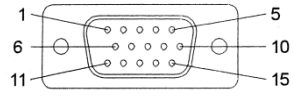

**ST-001**

Linear encoder, Sub-D (m), 9-pin RS-422 pin assignment

Sub-D (m), 9-pin	Function	
1	EA+	Encoder channel A+
2	EB+	Encoder channel B+
3	EC+	Encoder channel I+
4	EGND	Supply encoder GND
5	E5V	Encoder supply
6	EA-	Encoder channel A-
7	EB-	Encoder channel B-
8	EC-	Encoder channel I-
9	nc	
Housing	Shield	Shield of encoder, read head

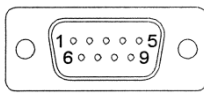

4.7.6 Technical Data

TECHNICAL DATA			
Travel range (°)	10		
Wobble (μrad)	± 125		
Weight (kg)	0.9		
Motor	DC-B-070	2Phase-020	
Measuring system			AE-060
Max. velocity (°/sec)	15	7	
Calculated resolution (°)	0.0002667 (RE)	0.0026665 (FS)	0.0001208
Typical resolution (°)	0.001	0.001	0.0005
Bidirectional repeatability (°)	± 0.004	± 0.004	± 0.0005
Unidirectional repeatability (°)	0.004	0.004	0.0005
Nominal current (A)	0.931	1.2	
Max. operating voltage (V)	36	<100	
Translation	675:1		
Accuracy	on request		
Velocity range (°/sec)	0.001..15		
Material	Aluminum, black anodized, stainless steel		

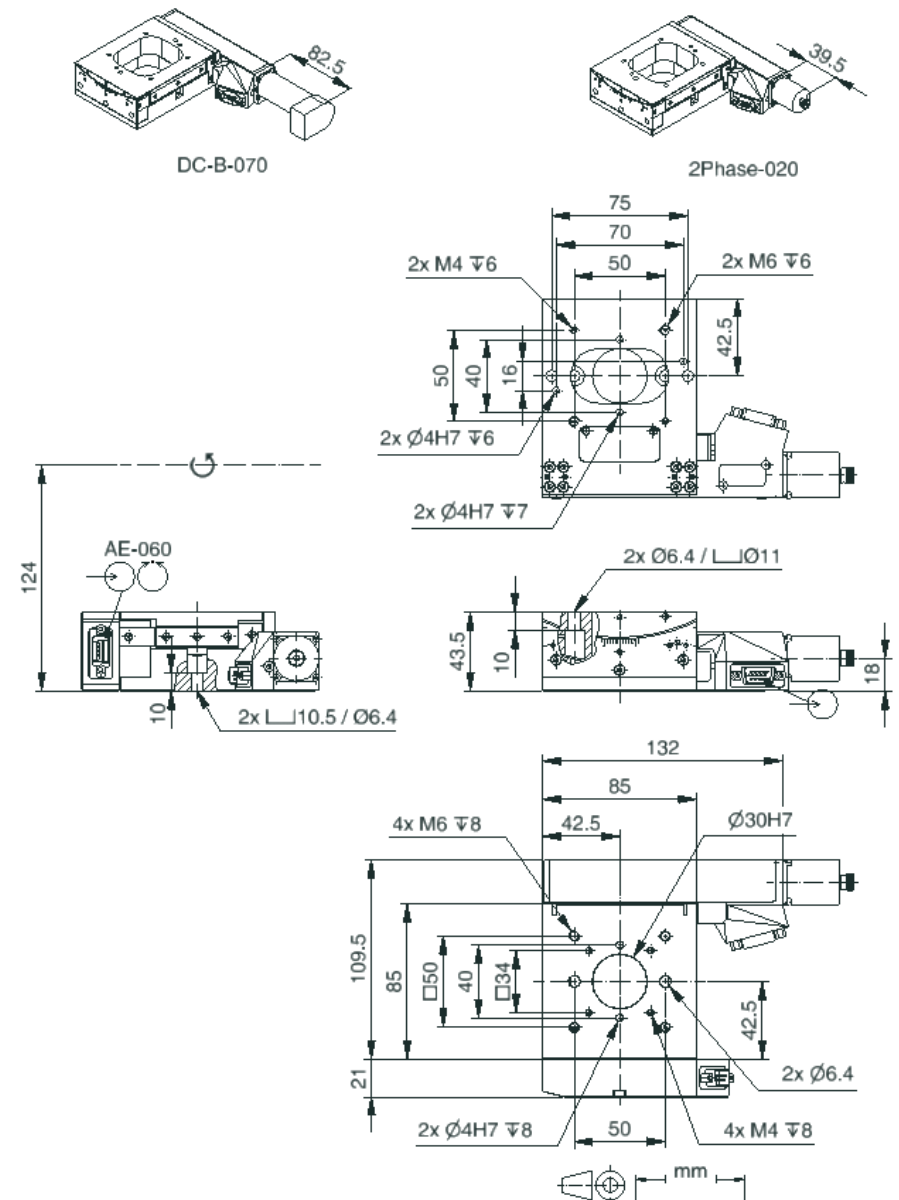

#### 4.8 Ambient Conditions

For indoor use only.

- The WT-85 was calibrated at an ambient temperature of 20 °C (+/- 3 °C).
- The permissible operating temperature is between 20 °C and 40 °C.
- The permissible relative humidity is between 20% and 80%.
- Always keep the WT-85 free of dirt, dust, and corrosive gases.

## 5. INSTALLATION

### 5.1 General Notes on Installation

#### Requirements

The goniometer must be screwed onto a surface with a flatness better than 5 µm.

It is necessary to make sure that no dust, dirt or other foreign bodies are between the surface and the axis, otherwise the properties of the axis can be impaired by mechanical tension.

To guarantee the prescribed specifications (see Internet [www.pimicos.com](http://www.pimicos.com)), the evenness of the mounting surface must be better than 5 µm. (Reference surface of PI miCos measuring granite is 3 µm).

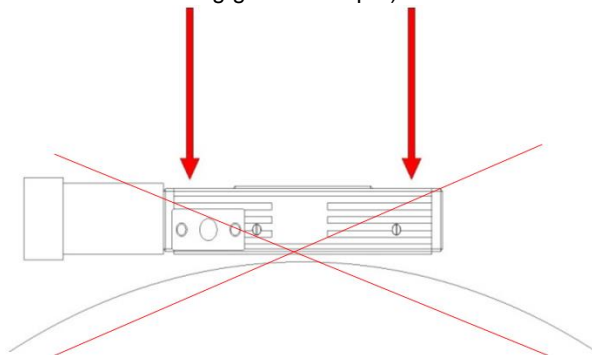

### 5.2 Mounting the goniometer

#### Requirements

You have read and understood the general notes on installation (see chapter 5.1).

#### Mounting material

- DIN 912 screws and DIN 6325 dowel pins, m6 tolerance field
- Tightening torques of the mounting screws to be used should not have values higher than the following:
- M3 DIN 912 1.5 Nm
  - M4 DIN 912 2.0 Nm
  - M5 DIN 912 2.5 Nm
  - M6 DIN 912 3.0 Nm

#### Mounting the WT-85

1. Affix the goniometer with the screws supplied.
2. Make sure that the screw heads do not protrude from the countersunk holes.
3. With M6x16 DIN 912 screws, the thread protrudes 6 mm out of the base plate of the WT-85.

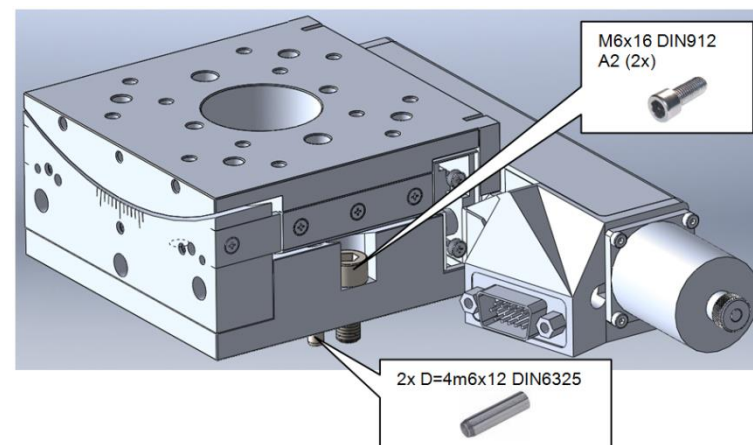

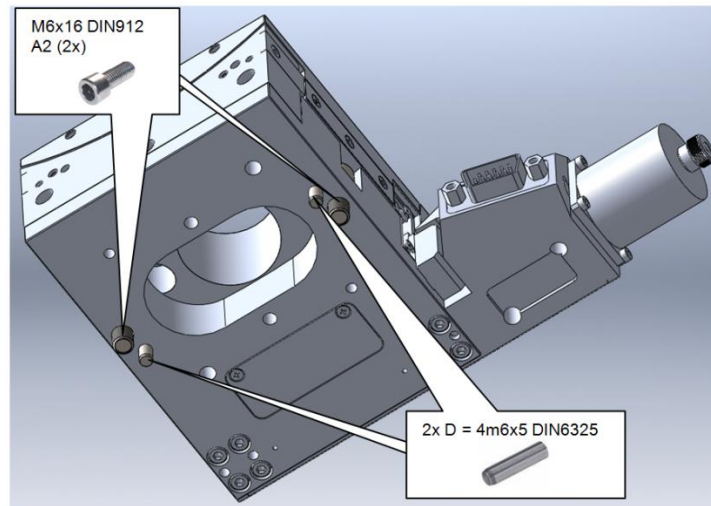

### 5.3 Mounting the Load

#### Requirements

You have read and understood the general notes on installation (see chapter 5.1).

The load must have an evenness better than 5  $\mu\text{m}$ .

It is necessary to make sure that no dust, dirt or other foreign bodies are between the load and the axis, otherwise the properties of the axis can be impaired by mechanical tension.

#### Mounting material

- DIN 912 screws and DIN 6325 dowel pins, m6 tolerance field
- Tightening torques of the mounting screws to be used should not have values higher than the following:
- M3 DIN 912 1.5 Nm
  - M4 DIN 912 2.0 Nm
  - M5 DIN 912 2.5 Nm
  - M6 DIN 912 3.0 Nm

#### Mounting the Additional Part

- Select the mounting position so that the existing fixing holes in the slider of the WT-85 can be used for the additional part to be mounted.
- Affix the additional part with the corresponding screws.

## 6. START-UP

### 6.1 General Notes on Start-Up

This goniometer must be started up with a suitable cable and the associated controllers.

## 7. MAINTENANCE

Depending on the operating conditions and the period of use of the WT-85, the following maintenance measures are required:

### Maintenance Run

The maintenance run serves to distribute the existing lubricant.

- To evenly distribute the existing lubricant on the stage guidings, perform a maintenance run over the entire angle range after 500 hours of operation, or after 1 year at the latest.
- If the goniometer is operated continuously in an industrial environment and its motion is over a small range (less than 70°), perform a maintenance run over one complete rotation after 5000 motion cycles.

### Lubrication

Under laboratory conditions, extra lubrication is only necessary in exceptional cases. For continuous industrial use, the lubrication intervals must be defined individually.

- Do not lubricate the WT-85 without consulting our customer service department (see chapter 9).

To lubricate, follow the instructions in the maintenance manual which you can obtain from our customer service department.

## 8. TROUBLESHOOTING

If the problem that occurred with your system is not listed in the table above or cannot be solved as described, contact our customer service department (see chapter 9).

## 9. CUSTOMER SERVICE

For inquiries and orders, contact your PI miCos sales engineer or send us and email ([info@pimicos.com](mailto:info@pimicos.com)).

If you have questions concerning your system, have the following information ready:

1. Product codes and serial numbers of all products in the system
2. Current firmware of the controller (if present)
3. Software version of the driver or the user software (if present)
4. User operating system (if present)

## 10. OLD EQUIPMENT DISPOSAL

In accordance with EU directive 2002/96/EC (WEEE), as of 13 August 2005, electrical and electronic equipment may not be disposed of in the member states of the EU via the municipal residual waste.

Dispose of your old equipment according to international, national, and local rules and regulations.

In order to fulfil the responsibility as the product manufacturer, PI miCos GmbH undertakes environmentally correct disposal of all old PI miCos equipment made available on the market after 13 August 2005 without charge.

Any old PI miCos equipment can be sent free of charge to the following address:

PI miCos GmbH  
Freiburger Strasse 30  
79427 Eschbach, Germany  
(<http://www.pimicos.com>)

## 11. EU Declaration of Conformity

An EU Declaration of Conformity has been issued for the WT-85 in accordance with the following European directives:

2014/30/EU, EMC Directive  
2011/65/EU, RoHS Directive

The applied standards certifying the conformity are listed below.

EMC: EN 61326-1:2013  
Safety: EN 61010-1:2010  
DIN EN ISO 12100:2010  
RoHS: EN 50581:2012