

Order no.	6234-9-			
DC-B-032	1			
2Phase-045	3			
DC-B-033	4			
26 mm (1")	0			
52 mm (2")	1			
102 mm (4")	2			
155 mm (6")	3			
without LS-012	0			
LS-012, length measuring system	1			
Pitch 1 mm / limit switch (Hall effect)	2			

PLS-85 Precision Linear Stage  
Order no. 6234-9-

User Manual  
Version: **00.002**

Date: 21.04.2017



© 2014 PI miCos GmbH, Eschbach, Germany. The text, photographs and drawings in this manual are protected by copyright. With regard thereto, PI miCos GmbH retains all rights. The use of any text, images and drawings is permitted only in part and only when indicating the source.

Subject to change without notice. This manual is superseded by any new release. The respective current revision is available for download on our website (<http://www.pimicos.com>).

File name:FILE-001452825\_0002\_MAN\_PLS-85\_9\_EN\_.DOCX/.pdf

Document-ID:DOC-000339521

## CONTENTS

### 1. ABOUT THIS DOCUMENT

- 1.1 Objective and Target Group of this User Manual
- 1.2 Symbols and Typographic Conventions
- 1.3 Other Applicable Documents

### 2. SAFETY

- 2.1 Intended Use
- 2.2 General Safety Instructions
  - 2.2.1 Organizational Measures
  - 2.2.2 Measures during Installation
  - 2.2.3 Measures during Start-Up
  - 2.2.4 Measures during Operation
  - 2.2.5 Measures during Maintenance

### 3. UNPACKING

### 4. PRODUCT DESCRIPTION

- 4.1 Features and Application Area
- 4.2 Model Overview
- 4.3 Product View
- 4.4 Safety Instructions
- 4.5 Scope of Delivery
- 4.6 Optional Accessories

### 4.7 Technical Features

- 4.7.1 Load Capacity Data
  - 4.7.2 Motors
  - 4.7.3 Measuring system
  - 4.7.4 Limit Switch
  - 4.7.5 Connector
  - 4.7.6 Technical Data
- 4.8 Ambient Conditions

### 5. INSTALLATION

- 5.1 General Notes on Installation
- 5.2 Mounting the Stage
- 5.3 Affixing the Load
- 5.4 Setting up an XY System

### 6. START-UP

- 6.1 General Notes on Start-Up

### 7. MAINTENANCE

### 8. TROUBLESHOOTING

### 9. CUSTOMER SERVICE

### 10. OLD EQUIPMENT DISPOSAL

### 11. EU DECLARATION OF CONFORMITY

### 1. ABOUT THIS DOCUMENT



All specifications in this user manual refer only to the standard products that are included in the PI miCos catalog. Any special features that are different, in particular special requests from customers, are supplied with the user manual as additional documentation in the form of "Technical Notes".



#### 1.1 Objective and Target Group of this User Manual

- This user manual contains all information required for the intended use of the PLS-85.
- Basic knowledge on servo systems, motion control concepts and applicable safety measures is assumed.
- The latest version of the user manual and answers to any questions can be obtained from our customer service department (see chapter 9)

#### 1.2 Symbols and Typographic Conventions

The symbols and typographic conventions used in this manual have the following meanings:

	<b>NOTICE</b>
	<b>Dangerous situation!</b> If not avoided, the dangerous situation will result in death, injuries or damage to the equipment -> Actions to take to avoid the situation

	<b>NOTICE</b>
	Information for easier handling, tricks, tips, etc.

#### 1.3 Other Applicable Documents

All products and programs from PI miCos mentioned in this documentation are described in separate user manuals.

The latest versions of the user manuals can be obtained from our customer service department (see chapter 9).

### 2. SAFETY

#### 2.1 Intended Use

The PLS-85 is a laboratory device as defined by DIN EN 61010-1. It is intended for indoor use and use in an environment which is free of dirt, oil, and lubricants.

In accordance with its design, the PLS-85 is intended for positioning, adjusting and shifting loads at various velocities on one axis. The PLS-85 can be mounted horizontally or vertically.

The intended use of the PLS-85 is only possible in conjunction with suitable electronics. The following options are available:

1. Drive electronics and controller with suitable software
  2. Combination device with suitable software
- The electronics are not included in the scope of delivery of the PLS-85.
  - The electronics must provide the required voltages. To ensure proper performance of the servo-control system, the electronics must be able to read out and process the signals from reference and limit switches, and from the incremental position encoder.

## 2.2 General Safety Instructions

The PLS-85 is built according to state-of-the-art technology and recognized safety standards. Improper use of the PLS-85 may result in personal injury and/or damage to the PLS-85.

1. Only use the PLS-85 for its intended purpose, and only use it if it is in good working order.
2. Read the user manual.
3. Immediately eliminate any faults and malfunctions that are likely to affect safety.

The operator is responsible for the correct installation and operation of the PLS-85.

### 2.2.1 Organizational Measures

#### User manual

- Always keep this user manual available when using the PLS-85. If the user manual is lost or damaged, contact our customer service department (see chapter 9).
- Add all information from the manufacturer such as supplements or technical notes to the user manual..
- Only use the device on the basis of the complete user manual. If your user manual is incomplete and is therefore missing important information, serious or fatal injury as well as damage to the equipment can result.
- Only install and operate the PLS-85 after you have read and understood this user manual.

#### Personnel Qualification

The PLS-85 may only be started up, operated, maintained and cleaned by authorized and appropriately qualified personnel.

### 2.2.2 Measures during Installation

The PLS-85 may be damaged by excessively long screws and wrongly mounted parts.

- When mounting the PLS-85, make sure that the mounting screws do not interfere with the stage motion. The screw heads must not protrude from the countersunk holes.
- Observe the depth of the mounting holes in the moving platform.
- Only use screws of the correct length for the respective mounting holes.
- Only mount the PLS-85 and the loads on the mounting fixtures (holes) intended for this purpose.
- The PLS-85 heats up during operation. High temperatures can influence your application.
- Install the PLS-85 so that your application is not affected by the dissipating heat.
- Cable extensions can affect the performance of the PLS-85 and damage the electronics.
- Only use genuine PI miCos parts to connect the PLS-85 to the electronic equipment.
- Do not use cable extensions. If you need longer cables, use cable extensions from PI miCos.
- Avoid short circuiting the lines for motor voltages since this can damage the electronics.

### 2.2.3 Measures during Start-Up

- Do not put your PLS-85 into operation until it is fully mounted and connected.

Your system can be damaged by uncontrolled oscillation of the PLS-85. Noise generated during operation of the PLS-85 is a typical sign of oscillation.

- Immediately switch off the servo-control system of the affected stage axes.
- Check the settings of the servo-control parameters.

Moving parts attached to devices with motorized stages can accelerate rapidly and generate high forces which can cause injury or damage to equipment.

The stage can carry out unintentional motions when being connected to the controller for the first time. Defective software or wrong operation of the software can also result in unintentional motions.

- Do not place any objects in areas where they can be caught by moving parts.

Collision of a part in motion at the end of the travel range and high accelerations can cause damage to or wear on the mechanical system.

- Ensure that the automatic limit switch halt is supported by the controller, or that it is activated in the controller.
- Do not disable the evaluation of the limit switch signals by the controller.
- Check the function of the limit switches at about 10 % to 20 % of the maximum velocity.
- In the event of a malfunction of the limit switches, stop the motion immediately.
- Ensure that the end of the travel range is approached at low velocity.

Set the control signal so that the moving part does not stop abruptly or try to continue motion at the end of the travel range.

- Determine the maximum velocity for your application.

### 2.2.4 Measures during Operation

- If noise occurs during operation, check the settings of the servo-control parameters of your controller.

The highest dynamic force and holding force is achieved at a control signal input level of 100%; however, the motor/drive may overheat during continuous operation.

- During continuous operation at room temperature, do not exceed 90 % of the control signal level.
- For continuous operation at other temperatures, observe the maximum allowable duty cycle in relation to the ambient temperature or obtain information from our customer service department (see chapter 9).

### 2.2.5 Measures during Maintenance

The PLS-85 is precision-adjusted.

- Do not loosen any sealed screws.

Dirt, oil, lubricants and condensation will render the motor/drive inoperable.

- Keep the PLS-85 free of dirt and condensation.

### 3. UNPACKING

1. Unpack the PLS-85 with care.
2. Compare the contents with the items listed in the contract and the packing list.
3. Inspect the contents for signs of damage. If there is any sign of damage or missing parts, contact PI Ceramic PI miCos immediately.
4. Keep all packaging materials in case the product needs to be returned.

**! WARNING**



Risk of suffocation for children. Keep the packaging foil away from children.  
Dispose of packaging materials according to environmental regulations.

**! NOTICE**



All specifications in this user manual only refer to the standard products that are included in the PI miCos catalog. Any special features that are different, in particular special requests from customers, are supplied with the user manual as additional documentation in the form of "Technical Notes".

### 4. PRODUCT DESCRIPTION

#### 4.1 Features and Application Area

Our products are designed specifically for use in the laboratory.

#### 4.2 Model Overview

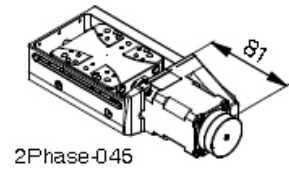
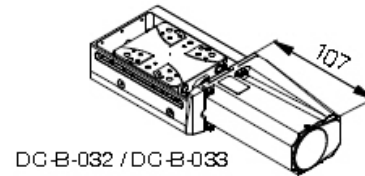

Bestellnr.	6234-9-			
DC-B-032		1		
2Phase-045		3		
DC-B-033		4		
26 mm (1")		0		
52 mm (2")		1		
102 mm (4")		2		
155 mm (6")		3		
ohne LS-012		0		
LS-012, Längenmesssystem		1		
Steigung 1 mm / Endschalter (Hall-Effekt)		2		

## 8 PLS-85 Precision Linear Stage

### 4.3 Product View

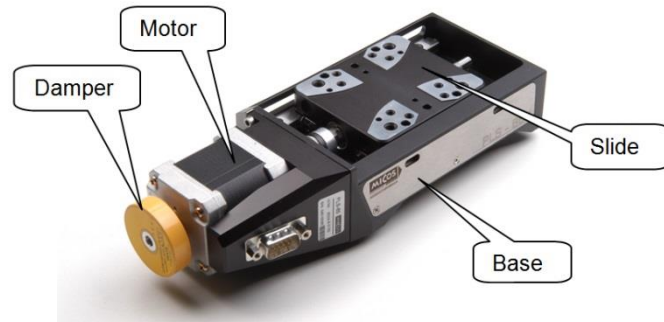

### 4.4 Safety Instructions

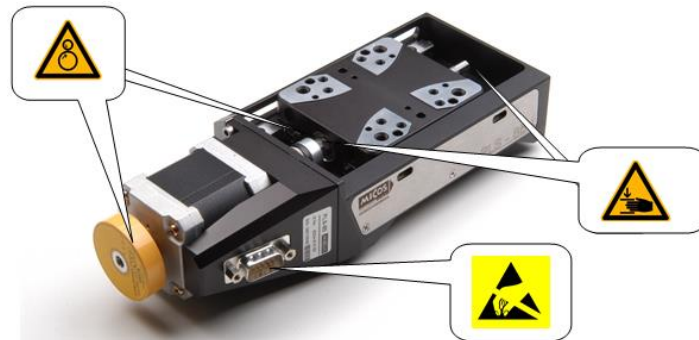

After removing the transport lock (if present), watch out for moving parts.



Protect the product against mechanical damage (knocking, shock, ...).  
Never start up an axis if you suspect it to be damaged or broken.  
Do not disconnect or connect connectors when voltage is present.



Risk of catching by rotating parts such as couplers and ball screws



Risk of squeezing or crushing by moving sliders at the places illustrated.



It is recommended that all persons entrusted with working with this product and who therefore come into contact with areas marked by the ESD warning symbol, are given training and a comprehensive explanation of the ESD warning symbol with respect to the ESD precautions.

### 4.5 Scope of Delivery

1. Stage according to order.
2. Mounting accessories (screws & pins) in fast-sealing bag.

### 4.6 Optional Accessories

For optional accessories, please ask our customer service department (chapter 9) for information on possible use of adapter plates or additional Z-brackets.



4.7 Technical Features

4.7.1 Load Capacity Data

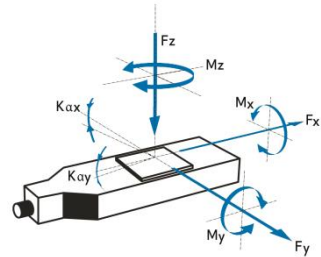

**FACTS**

Load characteristics	Fx(N)	Fy(N)	Fz(N)	Mx(Nm)	My(Nm)	Mz(Nm)	kax(μrad/Nm)	kay(μrad/Nm)
DC-B-032	50	60	80	30	25	20	40	70
2Phase-045	50	60	100	30	25	20	40	70
DC-B-033	50	60	80	30	25	20	40	70

4.7.2 Motors

**DC-B-032**

Motor type		DC brush 3257-024 CR
Nominal voltage	V	24
Max. continuous current	A	2.3
Electrical resistance	Ω	1.63
Electrical inductance	mH	0.27
Torque constant	mNm/A	37.7
Velocity constant	rpm/V	253
n/M slope curve	rpm/mNm	10.9
No load velocity	rpm	5900
Max. continuous velocity at nominal torque	rpm	5210
Inertia	kgm <sup>2</sup>	4.7E-6
Continuous torque	mNm	71
Rotary encoder		<b>RE-010 RS422 2-channel + index</b>
Encoder increments (quad counts)	n	2000

**RE-010**

Rotary optical encoder, RS-422 quadrature

Encoder type		HEDL rotary optical encoder
Quadrature counts per revolution	n	2000
Signal output		RS-422
Channels		2 + index
Supply voltage	VDC	4.5..5.5
Current consumption, typical (Vcc = 5 V DC)	mA	57
Frequency range	KHz	100
	kgm <sup>2</sup>	0.5E-7
Operating temperature	°C	-40..100

**2Phase-045**

Motor type		PK-245-01B 2-phase bipolar half coil
Phase current	A	1.2
Step angle	°	1.8
Steps	n	200
Coil resistance	Ω	3.3
Coil inductance	mH	2.8
Holding torque	mNm	320
Inertia	kgm <sup>2</sup>	6.8E-6
Weight	kg	0.35

**DC-B-033**

Motor type		DC brush 3257-024 CR
Nominal voltage	V	24
Max. continuous current	A	2.3
Electrical resistance	$\Omega$	1.63
Electrical inductance	mH	0.27
Torque constant	mNm/A	37.7
Velocity constant	rpm/V	253
n/M slope curve	rpm/mNm	10.9
No load velocity	rpm	5900
Max. continuous velocity at nominal torque	rpm	5210
Inertia	kgm <sup>2</sup>	5.1E-6
Continuous torque	mNm	71
Rotary encoder		<b>RE-015 RS422 2-channel + index</b>
Encoder increments (quad counts)	n	20000

**RE-015**

Rotary optical encoder RS-422 quadrature

Encoder type		RMHF rotary optical encoder
Quadrature counts per revolution	n	20000
Signal output		RS-422
Channels		2 + index
Supply voltage	VDC	4.5..5.5
Current consumption, typical (Vcc = 5 V DC)	mA	35
Frequency range	KHz	1000
Code disc inertia	kgm <sup>2</sup>	1E-7
Operating temperature	°C	-40..85

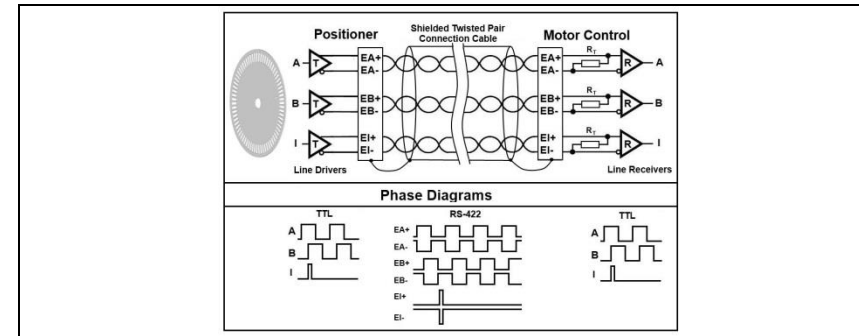

4.7.3 Measuring System

LS-012 / sin/cos signals

Optical encoder, sin/cos signals

Encoder type		Incremental linear LIA-20
Grating period	µm	20
Signal period	µm	20
Grating material		Steel
Signal output		1 Vpp differential sin-cos signals
Channels		2+1 index
Supply voltage	VDC	5 +/- 10%
Current consumption, Typical (Vcc = 5 V DC)	mA	<60
Max. scanning frequency	kHz	< 500
Operating temperature	°C	0..55
Linear expansion coefficient		Approx. 10.5 e <sup>-6</sup>
Absolute accuracy	µm	+/- 1
Index position		All 50 mm starting in the middle of travel
Connector		Pigtail lead, Sub-D (m) 15-pin

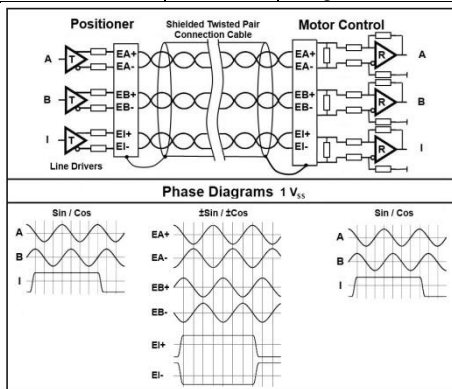

During power-up procedure of the encoder system the level of power voltage and signal lines must be below 250 mV. If the encoder system will be powered-up at a residual voltage between a range of 250 and 400 mV, internal sensor parameter will not set correctly. This will lead to incorrect encoder signals. This behaviour has to be observed especially during reset routines of controllers

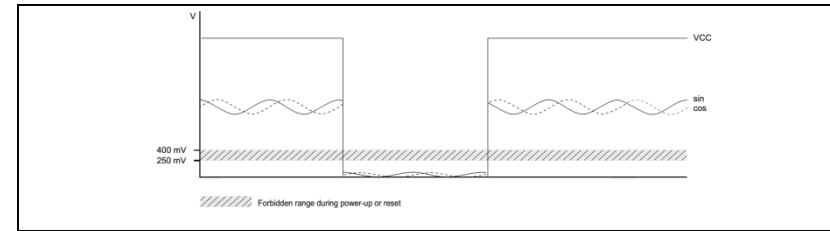

LS-012

Linear optical encoder RS-422 quadrature

Encoder type		Linear incremental LIA-20
Quadrature counts per mm	n	20000
Resolution	nm	50
Grating period	µm	20
Grating material		Steel
Interpolator	n	Integrated 100 times
Signal output		RS-422 quadrature
Channels		2+1 index
Supply voltage	VDC	5 +/- 10%
Current consumption, Typical (Vcc = 5 V DC)	mA	<200
Frequency range, Counter capability	MHz	8
Operating temperature	°C	0..55
Linear expansion coefficient		Approx. 10.5 e <sup>-6</sup>
Absolute accuracy	µm	+/- 1
Index position		All 50 mm starting in the middle of travel
Connector		Pigtail lead, Sub-D (m) 15-pin

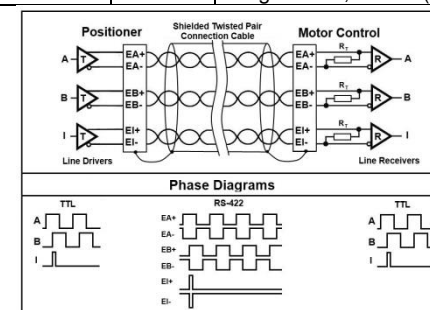

## 12 PLS-85 Precision Linear Stage

### 4.7.4 Limit Switch

#### Hall sensor limit switches, DC motor stages

Supply voltage, Vdd	V	5 ( connected to encoder supply)
Supply current	mA	<5 mA
Output configuration		Open collector
Max. sink current	mA	20
Contact type		Normal closed
Output Type		npn
Operating temperature	°C	40 to +85

#### Hall sensor limit switches, 2SM motor stages

Supply voltage, Vdd	V	3.8 .. 24
Supply current	mA	<5 mA
Output configuration		Open collector
Max. sink current	mA	20
Contact type		Normal closed
Output Type		npn
Operating temperature	°C	40 to +85

### 4.7.5 Connector

#### DC motor, Sub-D 15-pin motor assignment with Hall sensors

Sub-D (m) 15-pin	Function	
1	EA+	Encoder channel A+
2	EB+	Encoder channel B+
3	EI+	Encoder channel I+
4	EGND	Supply encoder & Hall sensor limit GND
6	M+	DC brush motor +
7	E2	Limit forward
8	nc	
9	EA-	Encoder channel A-
10	EB-	Encoder channel B-
11	EI-	Encoder channel I-
12	E5V	Encoder & Hall sensor limit supply voltage
14	M-	DC brush motor -
15	E1	Limit reverse

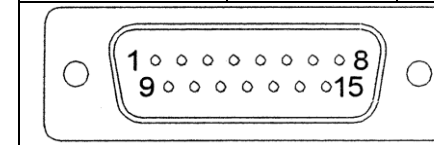

2SM motor, HD15 motor pinout with hall sensors

HD15m	Function	
1	MA+	Motor phase A+
2	MA-	Motor phase A-
3	nc	
4	nc	
5	MB+	Motor phase B+
6	MB-	Motor phase B-
7	nc	
8	nc	
9	nc	
10	LVcc	Hall sensor limit supply
11	nc	
12	nc	
13	LE2	Limit forward
14	LE1	Limit reverse
15	LGND	Hall sensor limit GND

The diagram shows a top-down view of the 15-pin connector. Pin 1 is at the top left, pin 5 at the top right, pin 6 at the bottom left, pin 10 at the bottom right, and pin 11 is located between pins 6 and 10.

Linear encoder, Sub-D 9-pin, sin/cos signals pin assignment

Sub-D (m) 15-pin	Function	
1	EA+	Encoder channel A+ (sin+)
2	EB+	Encoder channel B+ (cos+)
3	EI+	Encoder channel I+ (Ref+)
4	EGND	Supply encoder GND
5	E5V	Encoder supply
6	EA-	Encoder channel A- (sin-)
7	EB-	Encoder channel B- (cos-)
8	EI-	Encoder channel I- (Ref-)
9	nc	
Housing	Shield	Shield of encoder, read head

The diagram shows a top-down view of the 9-pin connector. Pin 1 is at the top left, pin 5 at the top right, pin 6 at the bottom left, and pin 9 at the bottom right.

Linear encoder, Sub-D 9-pin, RS-422 pin assignment

Sub-D (m) 15-pin	Function	
1	EA+	Encoder channel EA+
2	EB+	Encoder channel B+
3	EI+	Encoder channel I+
4	EGND	Supply encoder GND
5	E5V	Encoder supply
6	EA-	Encoder channel EA-
7	EB-	Encoder channel EB-
8	EI-	Encoder channel I-
9	nc	
Housing	Shield	Shield of encoder, read head

The diagram shows a top-down view of the 9-pin connector. Pin 1 is at the top left, pin 5 at the top right, pin 6 at the bottom left, and pin 9 at the bottom right.

# 14 PLS-85 Precision Linear Stage

## 4.7.6 Technical Data

### TECHNICAL DATA

Travel range (mm)	26	52	102	155
Straightness / Flatness (µm)	±1	±2	±4	±6
Pitch (µrad)	±60	±90	±120	±150
Yaw (µm)	±60	±80	±100	±130
Weight (kg)	0.9	1.2	1.5	1.8
Motor (Pitch 1 mm)	DC-B-032	2Phase-045	DC-B-033	
Linear scale				LS-012
Speed max. (mm/sec)	50	90	20	45
Resolution calculated (µm)	0.5	1 (RE)	5	10 (FS)
Resolution typical (µm)	0.5	1	0.05	0.1
Bi-directional Repeatability (µm)	±1	±1	±1	±1
Uni-directional Repeatability (µm)	0.5	1	0.1	0.2
Nominal Current (A)	2.3	1.2	2.3	
Voltage Range (V)	24		24	
Accuracy	on request			
Velocity range (mm/sec)	0.001 ... 100			
Material	Aluminum, black anodized			

Note: FS = full step, RE = rotary encoder  
 More info: Detailed information concerning motors and encoders, see appendix.

Travel(mm)	26	52	102	155
A	59	68.5	93.5	128
B	119.5	138.5	188.5	257.5
C	-	100	150	200

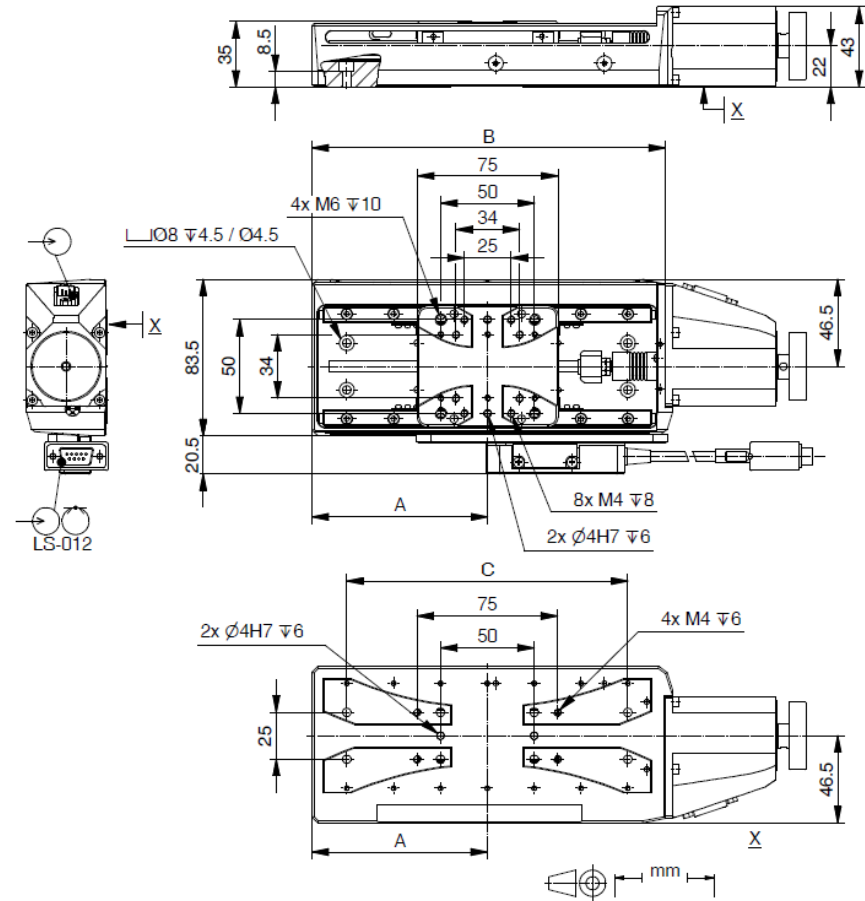
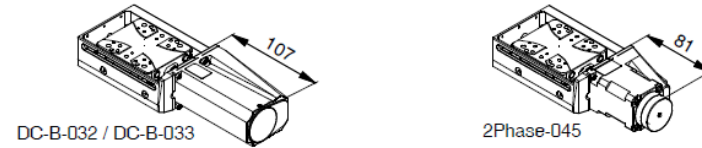

#### 4.8 Ambient Conditions

For indoor use only.

- The PLS-85 was calibrated at an ambient temperature of 20 °C (+/- 3 °C).
- The permissible operating temperature is between 20 °C and 40 °C.
- The permissible relative humidity is between 20% and 80%.
- Always keep the PLS-85 free of dirt, dust and corrosive gases.

## 5. INSTALLATION

### 5.1 General Notes on Installation

#### Prerequisite

The axis must be screwed onto a surface with an evenness better than 5 µm.

It is necessary to make sure that no dust, dirt or other foreign bodies are between the surface and the axis, otherwise the properties of the axis can be impaired by mechanical tension.

To guarantee the prescribed specifications (see Internet [www.pimicos.com](http://www.pimicos.com)), the evenness of the mounting surface must be better than 5 µm. (Reference surface of PI miCos measuring granite is 3 µm).

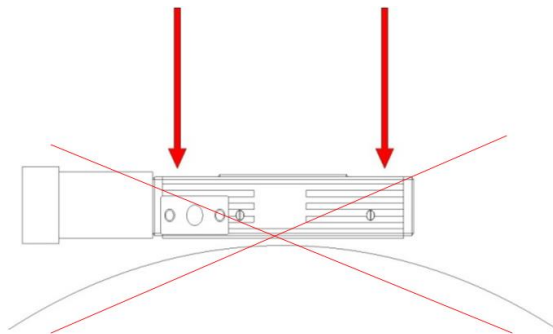

### 5.2 Mounting the Stage

#### Prerequisite

You have read and understood the general notes on installation (see chapter 5.1).

#### Mounting material

Screws, pins and auxiliary material or tools supplied (see chapter 4.5 "Scope of Delivery").

- DIN 912 screws and DIN 6325 dowel pins, m6 tolerance field

Tightening torques of the mounting screws to be used should not have values higher than the following:

- M3 DIN 912 1.5 nm
- M4 DIN 912 2.0 nm
- M5 DIN 912 2.5 nm
- M6 DIN 912 3.0 nm

#### Mounting the PLS-85

1. Displace the moving platform of the PLS-85 to the center position by hand until all of the countersunk holes in the base body required for mounting accessible (see following illustration).
2. Mount the stage with the screws supplied.
3. Make sure that the screw heads do not protrude from the countersunk holes.

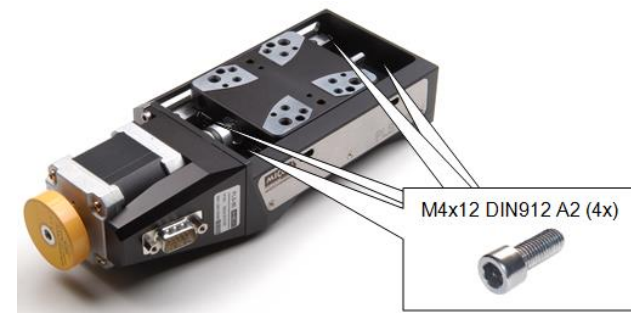

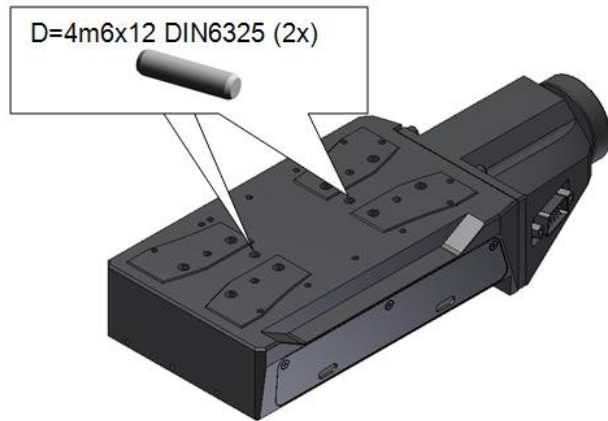

### 5.3 Affixing the Load

#### Prerequisite

You have read and understood the general notes on installation (see chapter 5.1).

#### Mounting material

- DIN 912 screws and DIN 6325 dowel pins, m6 tolerance field
- Tightening torques of the mounting screws to be used should not have values higher than the following:
- M3 DIN 912 1.5 nm
  - M4 DIN 912 2.0 nm
  - M5 DIN 912 2.5 nm
  - M6 DIN 912 3.0 nm

#### Mounting the Additional Part

- Select the mounting position so that the existing fixing holes in the slider of the PLS-85 can be used for the additional part to be affixed.
- Mount the additional part with the corresponding screws.

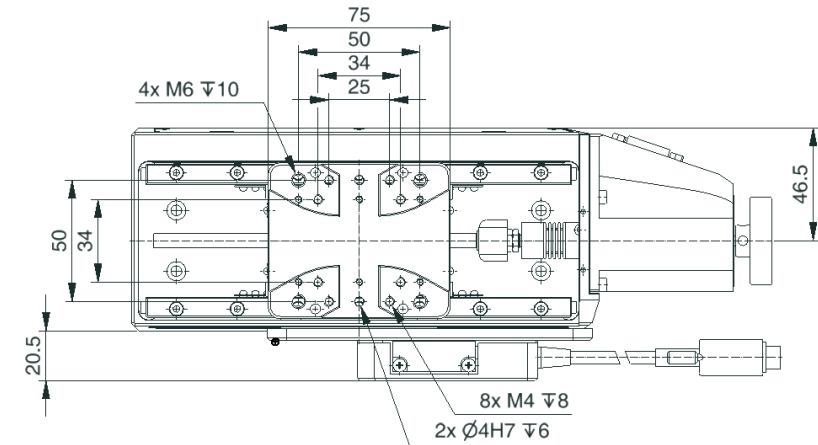



## 5.4 Setting up an XY System

Two PLS-85 can be stacked to form an XY system as follows:

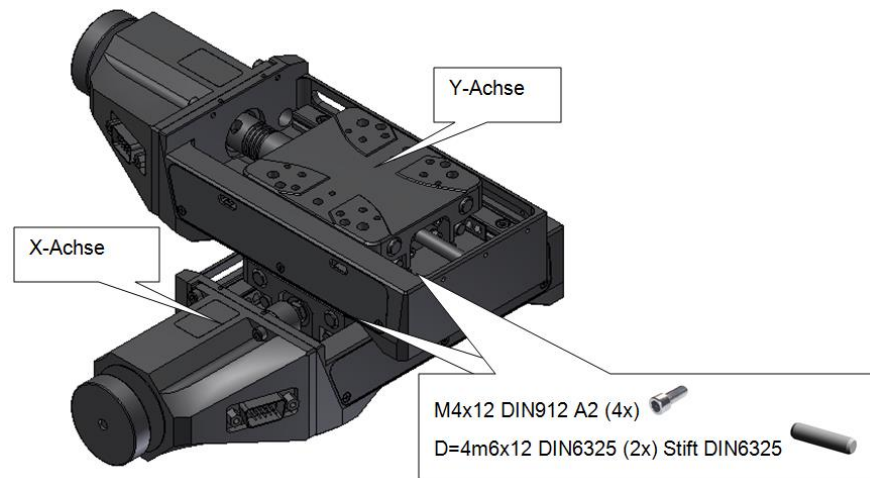

### Prerequisite

You have read and understood the general notes on installation (see chapter 5.1).

### Tools and accessories for combining PLS-85

- Use the mounting material supplied (for example, pins, screws and washers) with the PLS-85 to carry out XY mounting.
- The mounting procedure is described in chapter 5.2.0.
- Special adapter plates are not required for the standard axes.
- To prevent too much negative influence on the travel behavior of the Y axis, the shortest possible travel range should be selected. In extreme Y-axis positions, an adapter plate is used to allow sufficient space for stiffening.

## 6. START-UP

### 6.1 General Notes on Start-Up

This stage must be started up with a suitable cable and the associated controllers.

## 7. MAINTENANCE

Depending on the operating conditions and the period of use of the PLS-85, the following maintenance measures are required:

### Maintenance run

The maintenance run is performed to redistribute the existing lubricant on the guidings of the stage.

- To evenly distribute the existing lubricant on the stage guidings, perform a maintenance run across the entire travel range after 500 hours of operation, or after 1 year at the latest.
- If you operate the translation stage continuously over a small travel range (less than 20 percent of the entire travel range), perform a maintenance run every 5000 motion cycles across the entire travel range.

### Lubrication

Under laboratory conditions, the guidings of the stage need to be lubricated in exceptional cases only. For continuous industrial use, the lubrication intervals must be defined individually.

- Do not lubricate the guidings of the PLS-85 without consulting our customer service department (see chapter 9).
- To lubricate the guidings, follow the instructions specified in the maintenance manual, which you can obtain from our customer service department.

## 8. TROUBLESHOOTING

If the problem that occurred with your system is not listed in the table above or cannot be solved as described, contact our customer service department (see chapter 9).

## 9. CUSTOMER SERVICE

For inquiries and orders, contact your PI miCos sales engineer or send us and email ([info@pimicos.com](mailto:info@pimicos.com)).

If you have questions concerning your system, have the following information ready:

1. Product codes and serial numbers of all products in the system
2. Current firmware of the controller (if present)
3. Software version of the driver or the user software (if present)
4. User operating system (if present)

## 10. OLD EQUIPMENT DISPOSAL

In accordance with EU directive 2002/96/EC (WEEE), as of 13 August 2005, electrical and electronic equipment may not be disposed of in the member states of the EU via the municipal residual waste.

Dispose of your old equipment according to international, national, and local rules and regulations.

In order to fulfil the responsibility as the product manufacturer, PI miCos GmbH undertakes environmentally correct disposal of all old PI miCos equipment made available on the market after 13 August 2005 without charge.

Any old PI miCos equipment can be sent free of charge to the following address:

PI miCos GmbH  
Freiburger Strasse 30  
79427 Eschbach, Germany  
<http://www.pimicos.com>

## 11. EU DECLARATION OF CONFORMITY

An EC Declaration of Conformity has been issued for the PLS-85 in accordance with the following European directives:

2004/108/EC, EMC Directive  
2011/65/EU, RoHS Directive

The applied standards certifying the conformity are listed below.

EMC: EN 61326-1:2013  
Safety: EN 61010-1:2010  
DIN EN ISO 12100:2010  
RoHS: EN 50581:2012