

## V-277.630, V-277.631 PIMag<sup>®</sup> Voice Coil Linear Actuators



## Contents

<b>About this Document</b>	<b>4</b>
Symbols and Typographic Conventions .....	4
Figures .....	5
Other Applicable Documents .....	5
Downloading Manuals .....	5
<b>Intended Use</b>	<b>6</b>
<b>Product Description</b>	<b>7</b>
Model Overview .....	7
Product View .....	7
V-277.630 .....	7
V-277.631 .....	7
Product Labeling .....	8
Scope of Delivery .....	8
Accessories .....	9
Suitable Controllers .....	9
<b>Installation</b>	<b>9</b>
General Notes on Installation .....	9
Optional: Installing a Load on a V-277.630 .....	11
Optional: Changing the Contact Part of a V-277.631 .....	12
Removing the Transport Lock .....	12
Mounting the V-277 on a Surface .....	13
Connecting Motor Cable and Sensor Cable to the V-277 .....	13
<b>Startup and Operation</b>	<b>14</b>
General Notes on Startup and Operation .....	14
Temperature Dependency of the Nominal Current: Calculating the Nominal Current .....	15
Starting Up the V-277 with the C-413.1G Controller .....	15

---

<b>Maintenance</b>	<b>16</b>
<hr/>	
<b>Cleaning</b>	<b>16</b>
<hr/>	
<b>Customer Service</b>	<b>16</b>
<hr/>	
<b>Technical Data</b>	<b>17</b>
<hr/>	
Specifications .....	17
Maximum Ratings of V-277 .....	18
Ambient Conditions and Classifications of V-277 .....	19
Dimensions V-277.630 .....	19
Dimensions V-277.631 .....	21
Pin Assignment.....	23
Motor.....	23
Sensor .....	24
<hr/>	
<b>Old Equipment Disposal</b>	<b>25</b>
<hr/>	

## About this Document

This document contains the information needed for the intended use of the V-277.

Basic knowledge of servo systems, drive technologies and suitable safety measures is assumed.

## Symbols and Typographic Conventions

The following symbols and typographic conventions are used in this document:

### **DANGER**



#### **Imminently hazardous situation**

If not avoided, the hazardous situation will result in death or serious injury.



- Actions to take to avoid the situation

### **CAUTION**



#### **Dangerous situation**

If not avoided, the dangerous situation will result in minor injury.



- Actions to take to avoid the situation.

### **NOTICE**



#### **Dangerous situation**

If not avoided, the dangerous situation will result in damage to the equipment.

- Actions to take to avoid the situation.

### **INFORMATION**

Information for easier handling, tricks, tips, etc.

Symbol/Label	Meaning
1.	Action consisting of several steps whose sequential order must be observed
2.	
➤	Action consisting of one or several steps whose sequential order is irrelevant
•	List item
p. 5	Cross-reference to page 5

## Symbol/Label



## Meaning

Warning sign affixed to the product that refers to detailed information in this manual.

## Figures

For better understandability, the colors, proportions and degree of detail in illustrations can deviate from the actual circumstances. Photographic illustrations may also differ and must not be seen as guaranteed properties.

## Other Applicable Documents

Product	Document
C-413.1G PIMag® controller	C413T0008 user manual
C-413.2x PIMag® controller	MS224E user manual
PIMikroMove	SM148E software manual

The latest versions of the user manuals are available for download on our website.

## Downloading Manuals

### **INFORMATION**

If a manual is missing or problems occur with downloading:

- Contact our customer service department (p. 16).

### **INFORMATION**

For products that are supplied with software (CD in the scope of delivery), access to the manuals is protected by a password. Protected manuals are only displayed on the website after entering the password.

The password is included on the CD of the product.

### **For products with CD: Identify the password**

1. Insert the product CD into the PC drive.
2. Switch to the Manuals directory on the CD.
3. In the Manuals directory, open the Release News (file including *releasenews* in the file name).
4. Find the user name and the password in the section "User login for software download" in the Release News.

---

## Downloading manuals

1. Open the website **www.pi.ws**.
2. If access to the manuals is protected by a password:
  - a) Click **Login**.
  - b) Log in with the user name and password.
3. Click **Search**.
4. Enter the product code up to the period (e.g., C-413) into the search field.
5. Click **Start search** or press the  key.
6. Open the corresponding product detail page in the list of search results:
  - a) If necessary: Scroll down the list.
  - b) If necessary: Click **Load more results** at the end of the list.
  - c) Click the corresponding product in the list.
7. Click the **Downloads** tab.

The manuals are shown under **Documentation**.
8. Click the desired manual and save it to the hard disk of your PC or to a data storage medium.

## Intended Use

The V-277 is a laboratory device as defined by DIN EN 61010-1. It is intended to be used in interior spaces and in an environment which is free of dirt, oil, and lubricants.

The V-277 has a voice coil linear drive, a position sensor and, depending on the model, a force sensor as well. The V-277 is intended for positioning, adjusting and shifting loads in one axis at various velocities and with defined forces.

The V-277 is a linear actuator for applications in automation or handling technology. The V-277 is not intended for applications in areas in which a failure would present severe risks to human beings or the environment.

The intended use of the V-277 is only possible when installed and in connection with a suitable controller (p. 9).

## Product Description

### Model Overview

Two standard versions of the V-277 linear actuator are available. They differ with regard to the force sensor and thus the dimensions:

Model	Dimension	Force sensor present?
V-277.630	175 (max) mm x 72 mm x 85.7 mm	No
V-277.631	211.2 (max) mm x 72 mm x 85.7 mm	Yes

### Product View

V-277.630

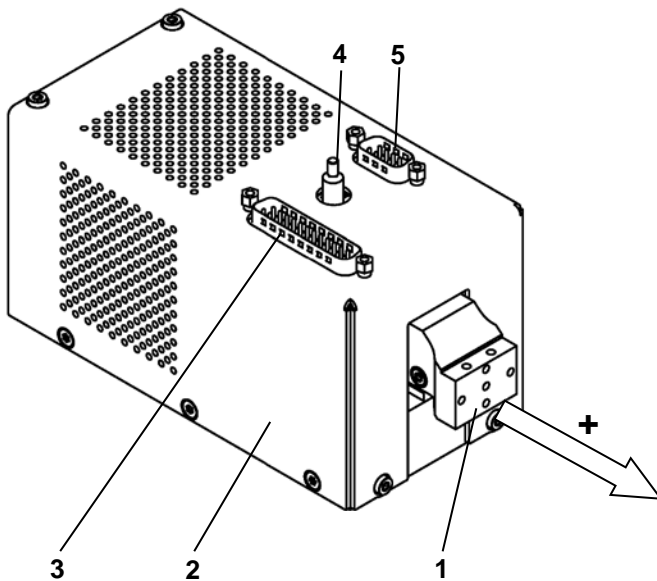

Figure 1: V-277.630

- 1 Pusher with M3 mounting holes
  - 2 Housing
  - 3 Sensor connection (D-sub25 (m))
  - 4 M3 Signal Ground pin
  - 5 Motor connection (D-sub9 (m))
- Arrow: Positive direction of motion

V-277.631

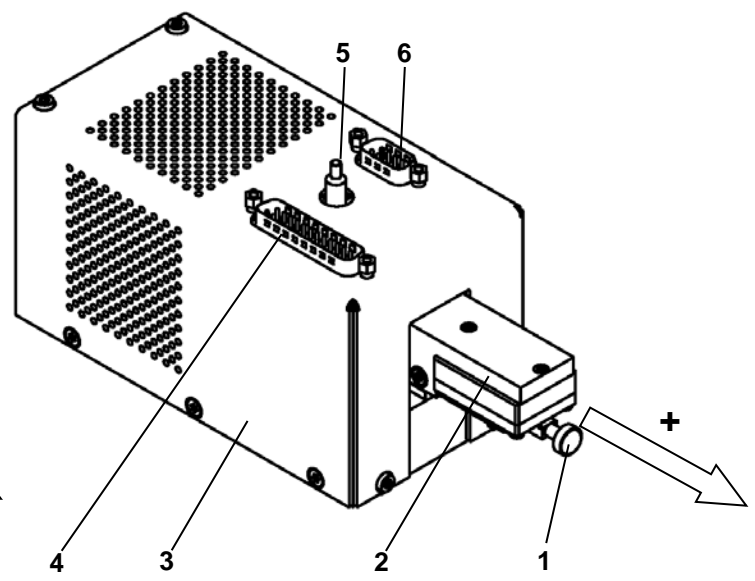









Figure 2: V-277.631

- 1 Contact part (aluminum with elastomer contact part), with M3 thread
  - 2 Pusher with integrated force sensor
  - 3 Housing
  - 4 Sensor connection (D-sub25 (m))
  - 5 M3 grounding pin, electrically connected to the contact part (1)
  - 6 Motor connection (D-sub9 (m))
- Arrow: Positive direction of motion

## Product Labeling

On the housing of the V-277, there is a type plate with the following information:

Labeling	Description
	Data matrix code (example; contains the serial number)
V-277.631	Product name (example), the characters following the period refer to the model
116003601	Serial number (example), individual for each V-275 Meaning of each position (from the left): 1 = internal information, 2 and 3 = year of manufacture, 4 to 9 = consecutive number
	Manufacturer's logo
	Warning sign "Pay attention to the manual!"
	Warning sign "Magnetic field"
	Prohibition sign for heart pacemakers, defibrillators, and other active implants
	Warning sign "Risk of crushing"
	Old equipment disposal (p. 25)
Country of origin: Germany	Country of origin
WWW.PI.WS	Manufacturer's address (website)
	CE conformity mark

## Scope of Delivery

Item number	Component
V-277	Linear actuator according to your order
K020B0085	Motor cable, 1.5 m, D-sub9 (m) 180° to D-sub9 (f) 90°, drag chain compatible
K030B0922	Sensor cable, 1.5 m, D-sub25 (m) 180° to D-sub25 (f) 90°, drag chain compatible
V277T0001	User manual for V-277 PIMag® actuators



## Accessories

Order number	Component
K020B0084	Motor cable, 3 m, D-sub 9 (m) 180° to D-sub 9 (f) 90°, drag chain compatible
K030B0902	Sensor cable, 3 m, D-sub 25 (m) 180° to D-sub 25 (f) 90°, drag chain compatible

## Suitable Controllers

Controller	Description
C-413.1G	PIMag® Motion Controller, 1 Channel, TCP/IP Interface, Bench-Top Device, Force Control Option

## Installation

### General Notes on Installation

#### **DANGER**



##### **Strong magnetic fields affect heart pacemakers!**

The V-277 contains permanent magnets that could impair the function of heart pacemakers and other active implants. **The magnetic fields are also effective when the V-277 is not connected to the controller/electric power.**

- Make sure that people with heart pacemakers and / or other active implants do not have access to the V-277.
- Ensure that hazardous areas are marked correspondingly.

#### **CAUTION**



##### **Risk of cuts and crushing!**

The V-277 linear actuator can generate high forces at high velocities. When a contact part with a small contact surface is installed on the pusher of the linear actuator, the pressure exerted by the pusher on a fixed part or obstacle during operation may be very high. If fingers or limbs get caught between the pusher of the linear actuator and a fixed part or obstacle during operation, there is a risk of minor injury from cuts and crushing.

- Use protective structures to keep limbs away from areas in which they could be seized by pushers.
- Observe the safety distances in accordance with the applicable standards when installing protective structures.
- If possible, use contact parts with a sufficiently dimensioned contact area, so that a pressure of 50 N / cm<sup>2</sup> is not exceeded when operating the linear actuator with the maximum specified force (p. 17).

## NOTICE



### Attraction of magnetizable objects!

The magnets in the V-277 can attract magnetizable objects such as loose screws. Objects attracted can damage the V-277.

- Make sure that there are no movable, magnetizable objects within a radius of at least 10 cm around the housing of the V-277.
- Apply corresponding precautions also for storage and transport of the V-277.

## NOTICE



### Damage to magnetically sensitive objects!

The magnets in the V-277 can damage magnetically sensitive objects such as magnetic data carriers and electronic devices.

- Make sure that there are no magnetically sensitive objects within a radius of at least 10 cm around the housing of the V-277.
- Apply corresponding precautions also for storage and transport of the V-277.

## NOTICE



### Damage due to mechanical overload of the pusher!

Excessive torque or forces on the pusher (p. 7) can damage the V-277 linear actuator.

- Do **not** exceed a maximum screw-in depth of 5 mm when mounting a contact part (V-277.631) or a load (V-277.630).
- Do **not** exceed the following maximum forces both in the positive and the negative direction of motion of the pusher:

11 N with V-277.631

20 N with V-277.630

- V-277.631 only: Do **not** exceed a maximum torque of 15 Ncm when changing the contact part. Use a torque wrench to tighten the contact part.
- V-277.631 only: Do **not** exceed the maximum lateral force acting on the contact part, which is calculated using the following formula:

$$F_{\max} = \frac{\text{Maximum torque [in Ncm]}}{\text{Maximum lever length [in cm]}} = \frac{15 \text{ Ncm}}{\text{Contact part length [in cm]} + 2.2 \text{ cm}}$$

(Contact part length: Overall length of the contact part excluding the mounting thread)

- V-277.630 only: Do **not** exceed a lateral force of 10 N acting on the pusher.

## Optional: Installing a Load on a V-277.630

### INFORMATION

- If you install a load on the pusher, you may have to adapt the settings of the controller due to the changed mass.

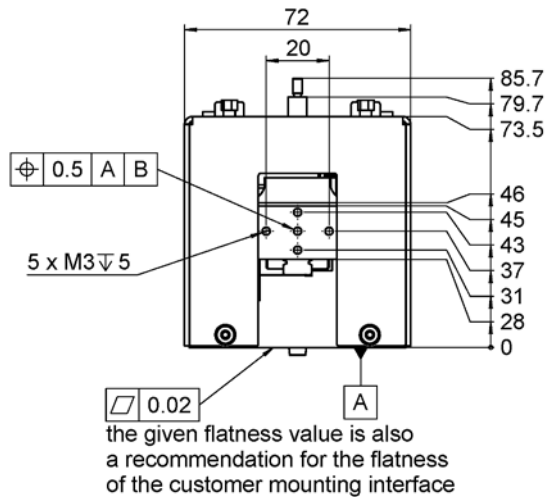

Figure 3: Installing a load with M3 screws

### Tools and accessories

- Suitable torque wrench
- At least one screw M3 of suitable length

### Requirements

- ✓ You have read and understood the general notes on installation (p. 9).

### Optional: Installing a load

- Screw the load onto the pusher of the V-277.630. When doing so, do **not** exceed a maximum screw in depth of 5 mm, and do **not** mechanically overload the pusher (see the safety instructions on p. 9 for the maximum permissible stress and load capacities). Observe a maximum torque of 110 Ncm.

## Optional: Changing the Contact Part of a V-277.631

### INFORMATION

- If you change the contact part of the pusher, you may have to adapt the settings of the controller due to the changed contact part mass and/or contact stiffness.
- Via the internal thread of the pusher, the contact part is electrically connected to the M3 grounding pin of the V-277.631.

### Tools and accessories

- Torque wrench

### Requirements

- ✓ You have read and understood the general notes on installation (p. 9).

### Optional: Changing the contact part

1. Unscrew the supplied contact part from the pusher of the V-277.631.
2. Screw the new contact part onto the pusher of the V-277.631, maximum torque: 15 Ncm.

## Removing the Transport Lock

The V-277 is delivered with a transport lock installed.

### NOTICE



#### Damage from transport lock that has not been removed!

Damage can occur to the V-277 if the transport lock has not been removed and a motion is commanded.

- Remove the transport lock from the V-277 before you start up the V-277 with the controller.

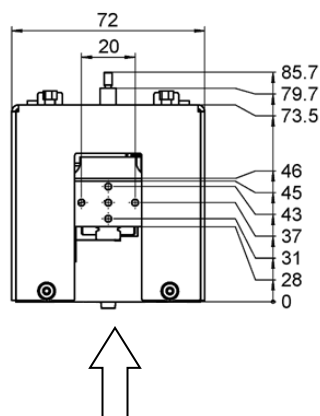

Figure 4: Transport lock of the V-277

- Remove the transport lock using a suitable tool (hex key for M3 screws).

## Mounting the V-277 on a Surface

### NOTICE



#### Screws that are too long!

Screws that are inserted too deeply can damage the V-277 linear actuator.

- Observe the depth of the mounting holes in the housing of the V-277 linear actuator.
- Only use screws of the correct length for the mounting holes:

Mounting option 1 (M4x6 mounting holes): Maximum screw-in depth is 6 mm

Mounting option 2 (M4x12 mounting holes): Maximum screw-in depth is 12 mm

You have the following mounting options:

Mounting option 1:  
4 × M4x6

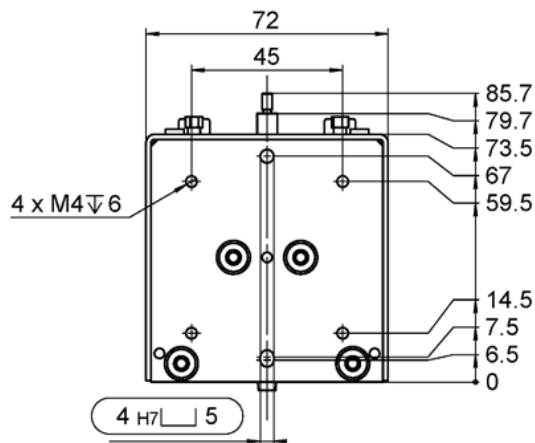

Figure 5: Mounting with four M4x6 screws

Mounting option 2:  
4 × M4x12

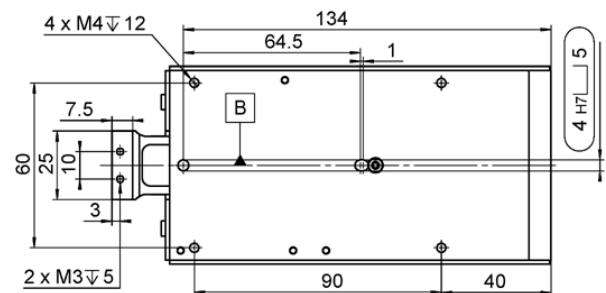

Figure 6: Mounting with four M4x12 screws

- To mount the V-277 linear actuator on a surface, use the four mounting holes of the selected option with suitable screws, see figures above.
- Tighten the screws with a maximum torque of 260 Ncm.

## Connecting Motor Cable and Sensor Cable to the V-277

### Requirements

- ✓ You have read and understood the general notes on installation (p. 9).
- ✓ Motor cable and sensor cable are **not** connected to the controller.

## Tools and accessories

- D-sub9 (m/f) motor cable, in the scope of delivery (p. 8)
- D-sub25 (m/f) sensor cable, in the scope of delivery (p. 8)

## Connecting the motor cable and sensor cable to the V-277

1. Connect the cable:
  - Connect the connector (f) of the motor cable to the 9-pin D-sub panel plug (m) of the V-277.
  - Connect the connector (f) of the sensor cable to the 25-pin D-sub panel plug (m) of the V-277.
2. Secure the connectors (f) with the integrated screws against being accidentally pulled out of the V-277.

# Startup and Operation

## General Notes on Startup and Operation

### DANGER



#### Strong magnetic fields affect heart pacemakers!

The V-277 contains permanent magnets that could impair the function of heart pacemakers and other active implants. **The magnetic fields are also effective when the V-277 is not connected to the controller/electric power.**

- Make sure that people with heart pacemakers and / or other active implants do not have access to the V-277.
- Ensure that hazardous areas are marked correspondingly.

### NOTICE



#### Overheating caused by selecting unfavorable nominal current!

The nominal current as specified in the data table (p. 17) applies when operating at room temperature: As the ambient temperature rises, adjust the nominal current that is driving the actuator.

Otherwise the actuator could be damaged by overheating.

- Calculate the nominal current according to the ambient temperature (p. 15).
- Adapt your application (acceleration, velocity, load) so that the calculated nominal current is not exceeded. If you have any questions, contact our customer service department (p. 16).

## INFORMATION

Since the drive of the V-277 linear actuator does not have any self-locking, an internal return mechanism is implemented (return / pulling force ranges from 3 N with 0 mm travel to 5 N with 15 mm travel). This return mechanism pulls the pusher of the V-277 in the negative direction of motion (towards the actuator housing) when switching off or rebooting the controller. The return motion is stopped by an integrated soft stop.

When the controller is switched on but the servo mode for the axis is switched off, the weight force of the moving mass is compensated for by the controller (see "AutoZero Procedure for Weight Force Compensation" in the C-413 user manual (MS224E)).

## Temperature Dependency of the Nominal Current: Calculating the Nominal Current

The nominal current as specified in the data table (p. 17) applies when operating at room temperature: As the ambient temperature rises, adjust the nominal current that is driving the actuator.

### Calculating the nominal current

- Calculate the nominal current according to the ambient temperature as follows:

$$I(T) = I(T_{\text{ref}}) \cdot \sqrt{\frac{T_{\text{max}} - T}{T_{\text{max}} - T_{\text{ref}}}}$$

With:

$I(T)$  = Nominal current, depending on ambient temperature  $T$

$T$  = Ambient temperature

$I(T_{\text{ref}})$  = Nominal current, determined at reference temperature  $T_{\text{ref}}$ , see specifications

$T_{\text{ref}}$  = Reference temperature (22 °C)

$T_{\text{max}}$  = Maximum temperature of actuator components, see specifications

## Starting Up the V-277 with the C-413.1G Controller

### Requirements

- ✓ You have read and understood the following sections:
  - General Notes on Installation (p. 9)
  - General Notes on Operation (p. 14)
- ✓ You have properly installed (p. 9) the actuator.
- ✓ You have read and understood the user manual of the controller.
- ✓ You have read and understood the manual of the PC software.

- 
- ✓ The controller and the required PC software have been installed. All connections on the controller have been set up (see user manual of the controller; the V-277 is connected via the motor cable and sensor cable).

## Starting up the V-277 with the C-413.1G controller

- Start up the actuator (see user manual of the controller).

## Maintenance

The V-277 is maintenance-free.

### NOTICE



#### Damage from opening the V-277!

Opening the housing causes damage to the V-277.

- Only loosen screws according to the instructions in this document.
- Do **not** open the V-277.

## Cleaning

- Before cleaning, make sure that you have disconnected the V-277 linear actuator from the controller.
- When necessary, clean the surfaces of the V-277 linear actuator with a cloth lightly dampened with a mild cleanser or disinfectant.

## Customer Service

For inquiries and orders, contact your PI sales engineer or send us an e-mail ([service@pi.de](mailto:service@pi.de)).

If you have questions concerning your system, have the following information ready:

- Product codes and serial numbers of all products in the system
- Firmware version of the controller (if present)
- Version of the driver or the software (if present)
- Operating system on the PC (if present)

If possible: Take photographs or make videos of your system that can be sent to our customer service department if requested.



## Technical Data

### Specifications

	V-277.630, V-277.631	Unit	Tolerance
Active axes	Z		
<b>Motion and positioning</b>			
Travel range	15	mm	
Integrated sensor	Optical linear encoder		
Sensor resolution <sup>1</sup>	10	nm	max.
Min. incremental motion	100	nm	typ.
Linearity error, closed-loop	1	%	typ.
Repeatability	±0.5	µm	typ.
Velocity	750	mm/s	max.
Force sensor resolution <sup>2</sup>	1	mN	max.
Smallest force step <sup>3</sup>	5	mN	typ.
<b>Mechanical properties</b>			
Bearing / guide	Linear recirculating ball bearing		
Motion straightness	±5	µm	±5 %
Moved mass without load	190	g	typ.
Return / pulling force range, with travel range from 0 mm to 15 mm	3 to 5	N	typ.
<b>Drive properties</b>			
Motor type	PIMag <sup>®</sup> voice coil drive, moving coil		
Coil resistance	6.3	Ω	typ., at 20°C
Coil inductance	2.70	mH	typ., at 1 kHz, at 20°C
Time constant	0.43	ms	typ.
Back EMF	14	Vs/m	
Force constant <sup>3</sup>	13.5	N/A	typ.
Motor constant	5.6	N/W <sup>1/2</sup>	
Current constant	0.072	A/N	typ.
Nominal current <sup>4</sup>	740	mA	max.
Peak current (max. 3 s)	1500	mA	

	V-277.630, V-277.631	Unit	Tolerance
Average push / pull force	10	N	nominal
Power dissipation of the coil with 100 % duty cycle	3.2	W	
Maximum push / pull force	20	N	max.
Permitted temperature for actuator components	60	°C	max.
<b>Miscellaneous</b>			
Operating temperature range	10 to 60	°C	
Material	Aluminum		
Mass	1850	g	±5 %
Cable length	1.5	m	
Motor connector	D-sub 9 (m)		
Sensor connector	D-sub 25 (m)		
Lifetime	> 10 <sup>7</sup>	cycles	
Recommended controller	C-413.1G		

<sup>1</sup> Interpolated resolution with C-413 controller.

<sup>2</sup> Refers to V-277.631 only. Interpolated resolution with C-413 controller.





<sup>3</sup> Refers to V-277.631 only

<sup>4</sup> Do not exceed for continuous operation.

The specifications apply to room temperature (22 °C ±3 °C), specifications may deviate outside of this range.

## Maximum Ratings of V-277

The voice coil drive of the V-277 linear actuator is designed for the following operating data.

Maximum Operating Voltage	Operating Frequency	Maximum Current (3 s)	Maximum Nominal Current	Maximum Continuous Power Consumption
				
48 V	≡	1.5 A	0.74 A	3.2 W

## Ambient Conditions and Classifications of V-277

The following ambient conditions and classifications must be observed for the V-277 linear actuator:

Area of application	For indoor use only
Maximum altitude	2000 m
Air pressure	1100 hPa to 795 hPa (corresponds to roughly 825 Torr to 596 Torr)
Relative humidity	Highest relative humidity 80 % for temperatures up to 31 °C Decreasing linearly to 50 % relative humidity at 40 °C
Storage temperature	-20 °C to 60 °C
Transport temperature	-20 °C to 60 °C
Overvoltage category	II
Protection class	I
Degree of pollution	1
Degree of protection according to IEC 60529	IP20

## Dimensions V-277.630

Dimensions in millimeters.

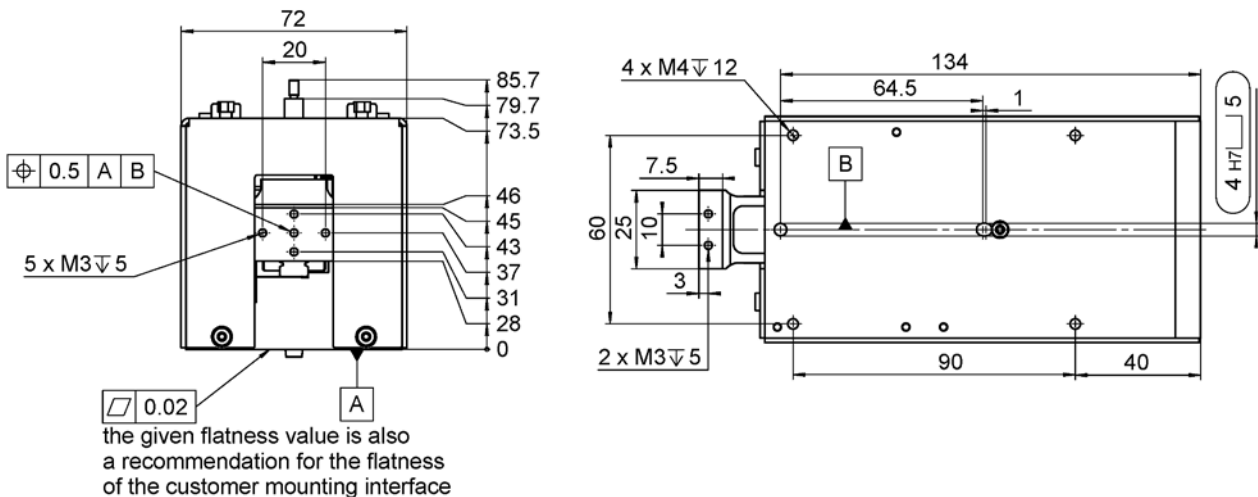

Figure 7: V-277.630; Left: Side with pusher, right: View from below

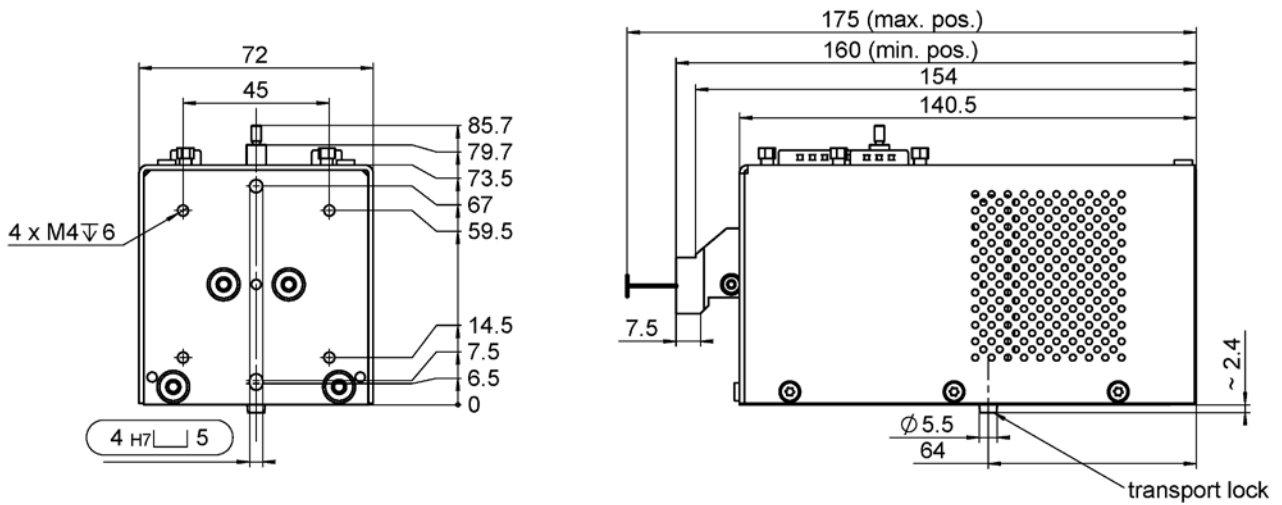

Figure 8: Lateral views of V-277.630

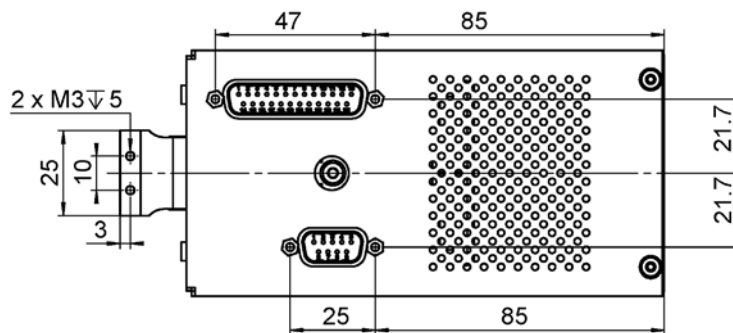

Figure 9: Top view of V-277.630

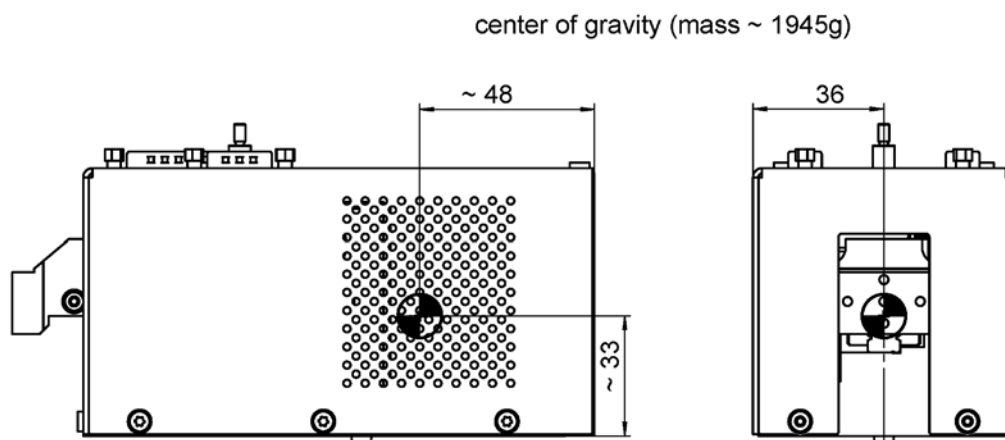

Figure 10: Location of center of gravity of V-277.630

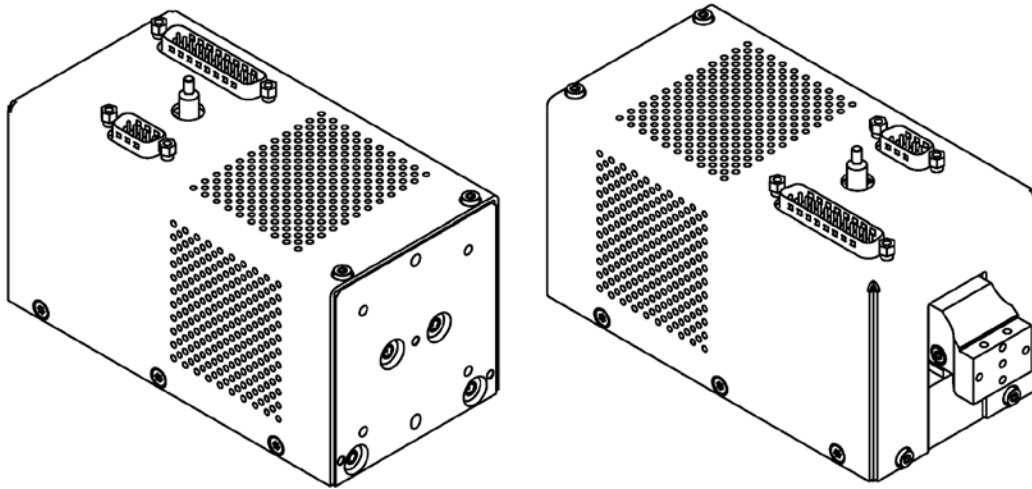

Figure 11: 3-dimensional view of V-277.630

## Dimensions V-277.631

Dimensions in millimeters.

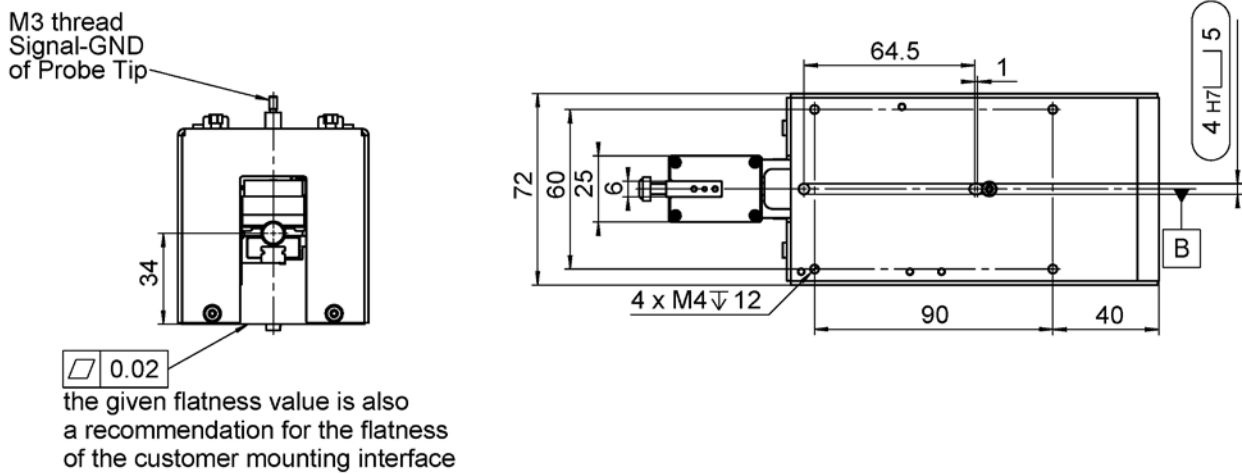

Figure 12: V-277.631; Left: Side with pusher with integrated force sensor and contact part, right: View from below

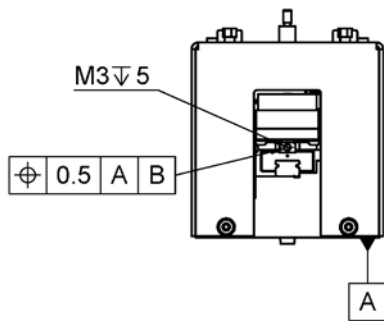

Figure 13: Side with pusher with integrated force sensor, here without contact piece of the force sensor

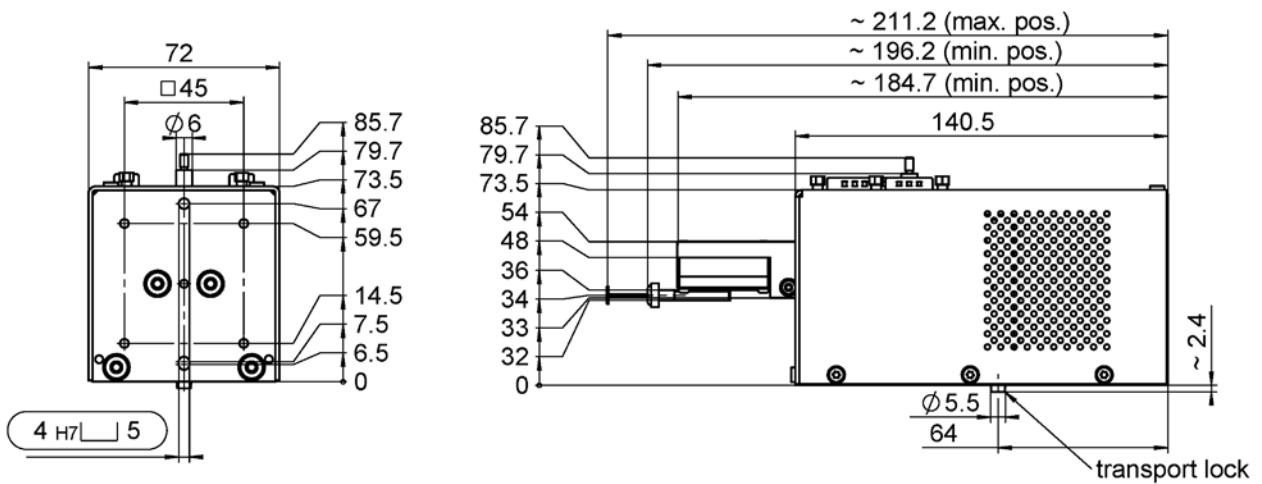

Figure 14: Lateral views of V-277.631

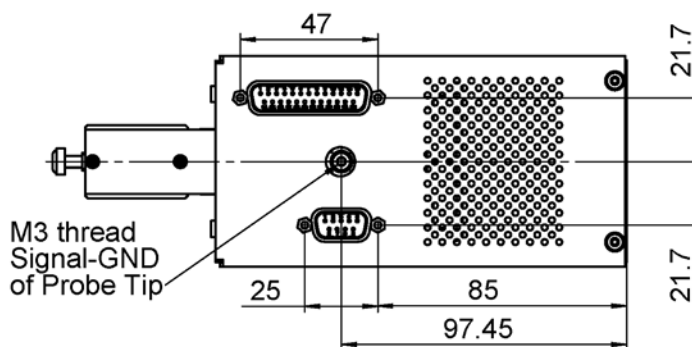

Figure 15: Top view of V-277.631

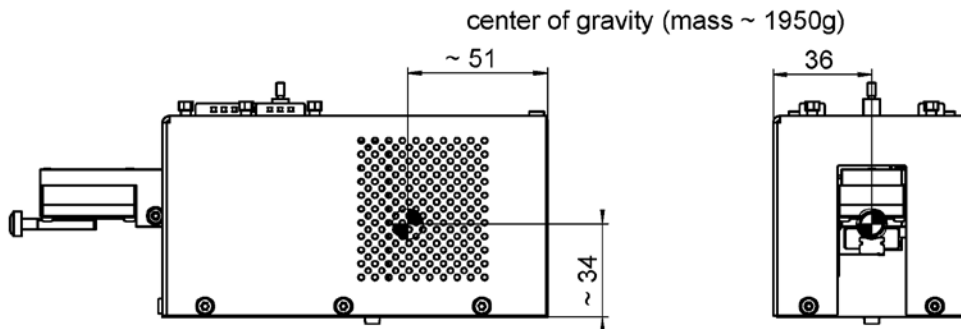

Figure 16: Location of center of gravity of V-277.631

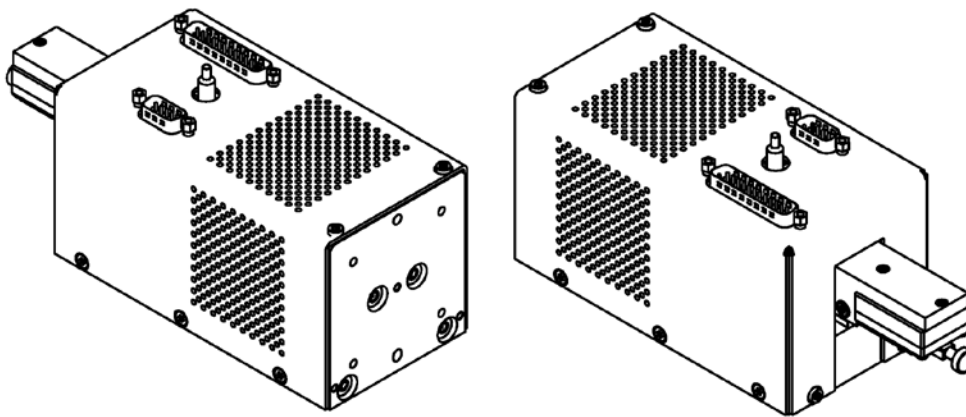

Figure 17: 3-dimensional view of V-277.631

## Pin Assignment

### Motor

D-sub panel plug, 9-pin, male.

Pin	Signal*
1	Motor P1
2	Motor N1
3	GND
4	NC**
5	NC**
6	Motor P1
7	Motor N1
8	NC**
9	NC**

#### Recommendations for cable assembly:

- Maximum cable length: 3 m
- The lines on pins 1, 2, 6 and 7 (Motor P1 und Motor N1) should be twisted and shielded together.

\* Motor output on C-413.1G:  $\pm 1.5$  A, regulated; 24 V max.

\*\* NC: not connected

## Sensor

### D-subpanel plug, 25-pin, male.

Pin	Signal
1	SPI_CLK+
2	GND
3	SPI_MOSI-
4	SPI_MISO+
5	GND
6	SPI_CS_Sensor1-
7	SPI_CS_Sensor2+
8	GND
9	SPI_CS_Memory1-
10	SPI_CS_Memory2-
11	Reference1-
12	Reference2-
13	5 V Sensor Supply
14	SPI_CLK-
15	SPI_MOSI+
16	GND
17	SPI_MISO-
18	SPI_CS_Sensor1+
19	GND
20	SPI_CS_Sensor2-
21	SPI_CS_Memory1+
22	SPI_CS_Memory2+
23	Reference1+
24	Reference2+
25	5 V Sensor Supply

#### Recommendations for cable assembly:

- Maximum cable length: 3 m
- The lines on the following pins should be implemented as twisted pairs:
  - 1 with 14
  - 3 with 15
  - 4 with 17
  - 6 with 18
  - 7 with 20
  - 9 with 21
  - 10 with 22
  - 11 with 23
  - 12 with 24
- The cable should have a total shield. This shield should be connected to the connector shells (this way, it will be connected to protective GND when connected to the sensor socket of the C-413.1G).



---

## Old Equipment Disposal

In accordance with the applicable EU law, electrical and electronic equipment may not be disposed of with unsorted municipal wastes in the member states of the EU.

When disposing of your old equipment, observe the international, national and local rules and regulations.

To meet the manufacturer's product responsibility with regard to this product, Physik Instrumente (PI) GmbH & Co. KG ensures environmentally correct disposal of old PI equipment that was first put into circulation after 13 August 2005, free of charge.

If you have old PI equipment, you can send it postage-free to the following address:

Physik Instrumente (PI) GmbH & Co. KG

Auf der Römerstr. 1

D-76228 Karlsruhe, Germany

