

Order no.	6447-9-	0	
DC-B-040		1	↓
2Phase-045		2	
Without AE-050		0	
AE-050, angle measuring system		1	

PRS-110 Precision Rotation Stage

Order no. 6447-9-

User Manual

Version: **00.003**

Date: 16.02.2016

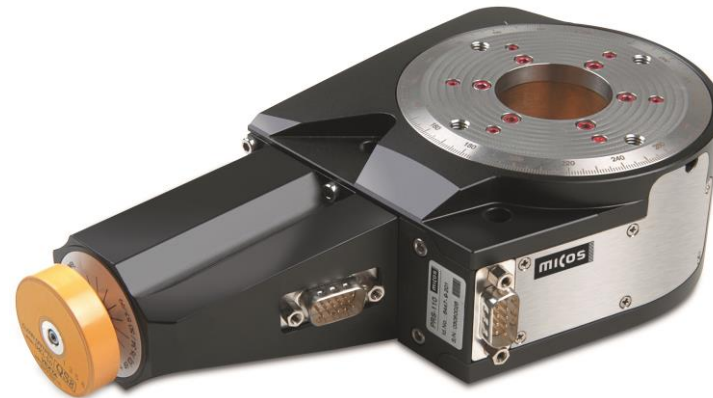

© 2016 PI miCos GmbH, Eschbach, Germany. The text, photographs and drawings in this manual are protected by copyright. With regard thereto, PI miCos GmbH retains all rights. The use of any text, images and drawings is permitted only in part and only when indicating the source.

Subject to change without notice. This manual is superseded by any new release. The latest release is available for download (<http://www.pimicos.com>).

File name:FILE-001466697_0003_MAN_PRS-110_9_EN.DOCX

Document

ID:DOC-000368608

CONTENTS

1. ABOUT THIS DOCUMENT

- 1.1 Objective and Target Group of this User Manual
- 1.2 Symbols and Typographic Conventions
- 1.3 Other Applicable Documents

2. SAFETY

- 2.1 Intended Use
- 2.2 General Safety Instructions
 - 2.2.1 Organizational Measures
 - 2.2.2 Measures during Installation
 - 2.2.3 Measures during Start-Up
 - 2.2.4 Measures during Operation
 - 2.2.5 Measures during Maintenance

3. UNPACKING

4. PRODUCT DESCRIPTION

- 4.1 Features and Application Area
- 4.2 Model Overview
- 4.3 Product View
- 4.4 Safety Instructions
- 4.5 Scope of Delivery
- 4.6 Optional Accessories

4.7 Technical Features

- 4.7.1 Load Capacity Data
- 4.7.2 Motors
- 4.7.3 Measuring system
- 4.7.4 Limit Switch
- 4.7.5 Connector
- 4.7.6 Technical Data

4.8 Ambient Conditions

5. INSTALLATION

- 5.1 General Notes on Installation
- 5.2 Mounting the Rotation Stage
- 5.3 Affixing the Load

6. START-UP

- 6.1 General Notes on Start-Up

7. MAINTENANCE

8. TROUBLESHOOTING

9. CUSTOMER SERVICE

10. OLD PRODUCT DISPOSAL

11. EU DECLARATION OF CONFORMITY

1. ABOUT THIS DOCUMENT

All specifications in this user manual refer only to the standard products that are included in the PI miCos catalog. Any special features that are different, in particular special requests from customers, are supplied with the user manual as additional documentation in the form of "Technical Notes".

1.1 Objective and Target Group of this User Manual

- This manual contains the necessary information on the intended use of the PRS-110.
- Basic knowledge of servo systems, motion control concepts, and applicable safety measures is assumed.
- The latest version of the user manual and answers to any questions can be obtained from our customer service department (see chapter 9)

1.2 Symbols and Typographic Conventions

The symbols and typographic conventions used in this manual have the following meanings:

	NOTICE Dangerous situation! If not avoided, the dangerous situation will result in death, injuries or damage to the equipment -> Actions to take to avoid the situation
--	---

	NOTICE Information for easier handling, tricks, tips, etc.
---	--

1.3 Other Applicable Documents

All products and programs from PI miCos mentioned in this documentation are described in separate user manuals.

The latest versions of the user manuals can be obtained from our customer service department (see chapter 9).

2. SAFETY

2.1 Intended Use

The PRS-110 is a laboratory device as defined by DIN EN 61010. It is intended for indoor use and use in an environment which is free of dirt, oil, and lubricants.

In accordance with its design, the PRS-110 is intended for single-axis positioning, adjusting and rotation of loads around an axis at various velocities. The PRS-110 can be mounted horizontally or vertically.

The intended use of the PRS-110 is only possible in conjunction with suitable electronics. The following options are available:

1. Drive electronics and controller with suitable software
 2. Combination device with suitable software
- The electronics are not included in the scope of delivery of the PRS-110.
 - The electronics must provide the required voltages. To ensure proper performance of the servo-control system, the electronics must be able to read out and further process the signals from the reference switch as well as those from the incremental position encoder.

2.2 General Safety Instructions

The PRS-110 is built according to state-of-the-art technology and recognized safety standards. Improper use of the PRS-110 can result in personal injury and/or damage to the PRS-110.

1. Only use the PRS-110 for its intended purpose, and only use it if it is in good working order.
2. Read the user manual.
3. Immediately eliminate any faults and malfunctions that are likely to affect safety.

The operator is responsible for the correct installation and operation of the PRS-110.

2.2.1 Organizational Measures

User Manual

- Always keep this user manual available when using the PRS-110. If the user manual is lost or damaged, contact our customer service department (see chapter 9).
- Add all information from the manufacturer such as supplements or technical notes to the user manual.
- Only use the device on the basis of the complete user manual. If your user manual is incomplete and is therefore missing important information, serious or fatal injury as well as damage to the equipment can result.
- Only install and operate the PRS-110 after you have read and understood this user manual.

Personnel Qualification

The PRS-110 may only be started up, operated, maintained, and cleaned by authorized and appropriately qualified personnel.

2.2.2 Measures during Installation

The PRS-110 may be damaged by excessively long screws and wrongly mounted parts.

- When mounting the PRS-110, make sure that the mounting screws do not interfere with the stage motion. The screw heads must not protrude from the countersunk holes.
- Observe the depth of the mounting holes in the moving platform.
- Only use screws of the correct length for the respective mounting holes.
- Only mount the PRS-110 and the loads on the mounting fixtures (holes) intended for this purpose.
- The PRS-110 heats up during operation. High temperatures can influence your application.
- Install the PRS-110 so that your application is not affected by the dissipating heat.
- Cable extensions can affect the performance of the PRS-110 and damage the electronics.
- Only use genuine PI miCos parts to connect the PRS-110 to the electronic equipment.
- Do not use cable extensions. If you need longer cables, use cable extensions from PI miCos.
- Avoid short circuiting the lines for motor voltages since this can damage the electronics.

2.2.3 Measures during Start-Up

- Do not put your PRS-110 into operation until it is fully mounted and connected.

Your system can be damaged by uncontrolled oscillation of the PRS-110. Noise generated during operation of the PRS-110 is a typical sign of oscillation.

Immediately switch off the servo-control system of the affected rotational axis.

- Check the settings of the servo-control parameters.

Moving parts attached to devices with motorized rotation stages can accelerate rapidly and generate high forces which can cause injury or damage to equipment.

Unintentional motion of the rotation stage is possible when it is connected to the controller for the first time. Defective software or incorrect operation of the software can also result in unintentional motions.

- Do not place any objects in areas where they can be caught by moving parts.

Collision of a part in motion at the end of the travel range and high accelerations can cause damage to or wear on the mechanical system.

- Ensure that the automatic limit switch halt is supported by the controller, or that it is activated in the controller.
- Do not disable the evaluation of the limit switch signals by the controller.
- Check the function of the limit switches at about 10 % to 20 % of the maximum velocity.
- In the event of a malfunction of the limit switches, stop motion immediately.
- Ensure that the end of the travel range is approached at low velocity.

Set the control signal so that the moving part does not stop abruptly or try to continue motion at the end of the travel range.

- Determine the maximum velocity for your application.

2.2.4 Measures during Operation

- If noise occurs during operation of the PRS-110, check the settings of the servo-control parameters of your controller.

The highest dynamic force and holding force is achieved at a control signal level of 100%; however, the motor/drive may overheat during continuous operation.

- During continuous operation at room temperature, do not exceed a maximum of 90% of the control signal level.
- For continuous operation at other temperatures, observe the maximum permissible duty cycle in relation to the ambient temperature or contact our customer service department for more information (see chapter 9).

2.2.5 Measures during Maintenance

The PRS-110 is precision adjusted.

- Do not loosen any sealed screws.

Dirt, oil, lubricants and condensation will render the motor/drive inoperable.

- Keep the PRS-110 free of lubricants.
- Keep the PRS-110 free of dirt and condensation.

3. UNPACKING

1. Unpack the PRS-110 with care.
2. Compare the contents with the items listed in the contract and the packing list.
3. Inspect the contents for signs of damage. If there is any sign of damage or missing parts, contact PI miCos immediately.
4. Keep all packaging materials in case the product needs to be returned.

! WARNING



Risk of suffocation for children. Keep the packaging foil away from children.
 Dispose of packaging materials according to environmental regulations.

! NOTICE



All specifications in this user manual only refer to the standard products that are included in the PI miCos catalog. Any special features that are different, in particular special requests from customers, are supplied with the user manual as additional documentation in the form of "Technical Notes".

4. PRODUCT DESCRIPTION

4.1 Features and Application Area

Our products are designed specifically for use in the laboratory.

4.2 Model Overview

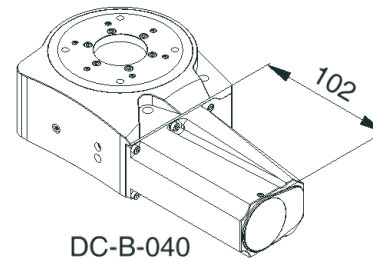

DC-B-040

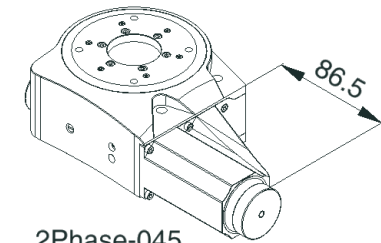

2Phase-045

Order no.	6447-9-	0	
DC-B-040		1	↓
2Phase-045		2	
Without AE-050		0	
AE-050, angle measuring system		1	

4.3 Product View



8 PRS-110 Precision Rotation Stage

NOTICE



Modifications and servicing on this axis may only be carried out by the manufacturer or persons authorized by the manufacturer. The manufacturer is not liable for damage caused by unauthorized tampering. Unauthorized tampering invalidates the guarantee.

4.4 Safety Instructions

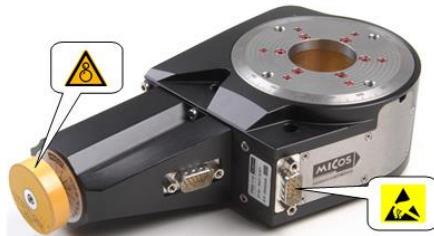

NOTICE



Protect the product against mechanical damage (knocking, shock, ...).
Never start up an axis if you suspect it to be damaged or broken.
Do not disconnect or connect connectors when voltage is present.

WARNING



Risk of catching by rotating parts such as couplers and ball screws

WARNING



It is recommended that all persons entrusted with working with this product and who therefore come into contact with areas marked by the ESD warning symbol, are given training and a comprehensive explanation of the ESD warning symbol with respect to the ESD precautions.

4.5 Scope of Delivery

- Rotation stage according to order.
- Mounting accessories (screws & pins) in fast-sealing bag.

4.6 Optional Accessories

Obtain more information on optional accessories from our customer service department (chapter 9).

4.7 Technical Features

4.7.1 Load Capacity Data

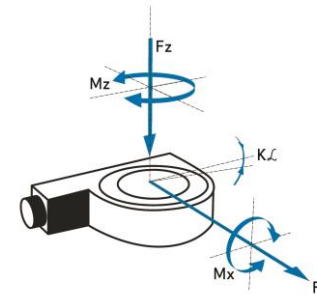

FACTS

Load characteristics	F _x (N)	F _z (N)	M _x (Nm)	M _z (Nm)	k _{ax} (μrad/Nm)
DC-B-040	50	100	40	3	30
2Phase-045	50	100	40	3	30

4.7.2 Motors

DC-B-040

Motor type		DC brush 3863-024 C
Nominal voltage	V	24
Max. continuous current	A	4
Electrical resistance	Ω	0.64
Electrical inductance	mH	0.180
Torque constant	mNm/A	39.8
Velocity constant	rpm/V	240
n/M slope curve	rpm/mNm	3.9
No load velocity	rpm	5800
Max. continuous velocity at nominal torque	rpm	5510
Inertia	kgm ²	12.0E-6
Continuous torque	mNm	129
Rotary encoder		RE-015 RS422 2-channel + index
Encoder increments (quad counts)	n	20000

RE-015

Rotary optical encoder RS-422 quadrature

Encoder type		RMHF rotary optical encoder
Quadrature counts per revolution	n	20000
Signal output		RS-422
Channels		2 + index
Supply voltage	VDC	4.5..5.5
Current consumption, Typical (Vcc = 5 V DC)	mA	35
Frequency range	KHz	1000
Code disc inertia	kgm ²	1E-7
Operating temperature	°C	-40..85

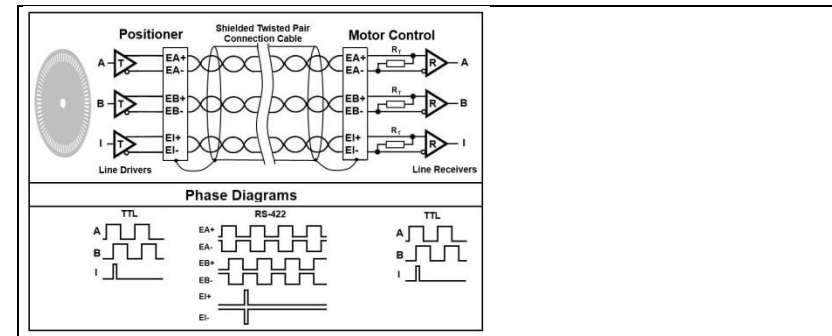

2Phase-045

2-phase stepper - motor PK-245-01B

Motor type		PK-245-01B 2-phase bipolar half coil
Phase current	A	1.2
Step angle	°	1.8
Steps	n	200
Coil resistance	Ω	3.3
Coil inductance	mH	2.8
Holding torque	mNm	320
Inertia	kgm ²	6.8E-6
Weight	kg	0.35

4.7.3 Measuring system

AE-050

Angular optical encoder RS-422 quadrature

Encoder type		Angular Incremental RIK
Quadrature Counts per 360°	n	1 800 000
Resolution	deg	0.0002
Grating period	μ m	20
Grating material		Steel
Interpolator	n	Integrated 50 times
Signal output		RS-422 quadrature
Channels		2+1 index
Supply voltage	VDC	5 +/- 10%
Current consumption, Typical (Vcc = 5 V DC)	mA	<150

10 PRS-110 Precision Rotation Stage

Frequency range, Counter capability	MHz	8
Operating temperature	°C	0..55
Absolute accuracy	deg	<+/- 0.006
Index position relative to limit reverse	deg	30
Connector		Sub-D (m)

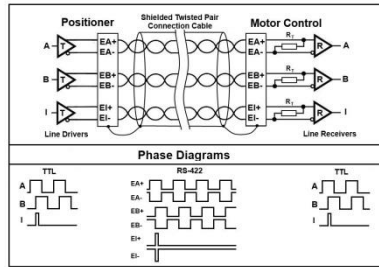

ST-001

Linear encoder, Sub-D 9-pin, RS-422 pin assignment

DB9m	Function	
1	EA+	Encoder channel EA+
2	EB+	Encoder channel B+
3	EC+	Encoder channel I+
4	EGND	Supply encoder GND
5	E5V	Encoder supply
6	EA-	Encoder channel EA-
7	EB-	Encoder channel EB-
8	EC-	Encoder channel I-
9	nc	
Housing	Shield	Shield of encoder, read head

4.7.4 Limit Switch

Mechanical limit switches

Max. voltage (resistive load)	V	30
Max. current (resistive load)	A	1
Contact type		Normal closed

Operations		>5x10 ⁴
Operating temperature	°C	-40 to +85

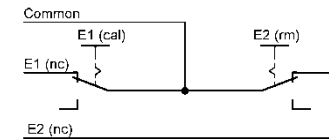

4.7.5 Connector

DC motor, Sub-D 15-pin motor pin assignment with mechanical switches

DB15m	Function	
1	EA+	Encoder channel A+
2	EB+	Encoder channel B+
3	EC+	Encoder channel I+
4	EGND	Supply encoder GND
6	M+	DC brush motor +
7	LE2	Limit forward
8	LCOM	Limit common
9	EA-	Encoder channel A-
10	EB-	Encoder channel B-
11	EC-	Encoder channel I-
12	E5V	Encoder supply voltage
14	M-	DC brush motor -
15	LE1	Limit reverse

2SM motor, HD15 motor pin assignment with mechanical sensors

HD15m	Function	
1	MA+	Motor phase A+
2	MA-	Motor phase A-
3	nc	
4	nc	
5	MB+	Motor phase B+
6	MB-	Motor phase B-
7	nc	
8	nc	

9	nc	
10	nc	
11	nc	
12	nc	
13	LE2	Limit forward
14	LE1	Limit reverse
15	LCOM	Limit common

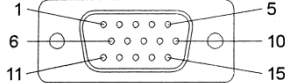

4.7.6 Technical Data

TECHNICAL DATA			
Travel range (°)	360		
Evenness (µm)	±1		
Eccentricity	±2.5		
Pitch angle (µrad)	±15		
Weight (kg)	2.6		
Motor	DC-B-040	2Phase-045	
Measuring system			AE-050
(°)	1	1	
Max. velocity (°/sec)	200	50	
Typical resolution (°)	0.002	0.002	0.0002
Calculated resolution (°)	0.0002 (RE)	0.02(FS)	0.0001
Bidirectional repeatability (°)	± 0.01	± 0.01	0.0002
Unidirectional repeatability (°)	0.002	0.002	0.0002
Nominal current (A)	3.8	1.2	
Max. operating voltage (V)	24		
Translation	90 : 1		
Accuracy	on request		
Velocity range (°/sec)	0.002...200		
Material	Aluminum, black anodized, stainless steel, red bronze		

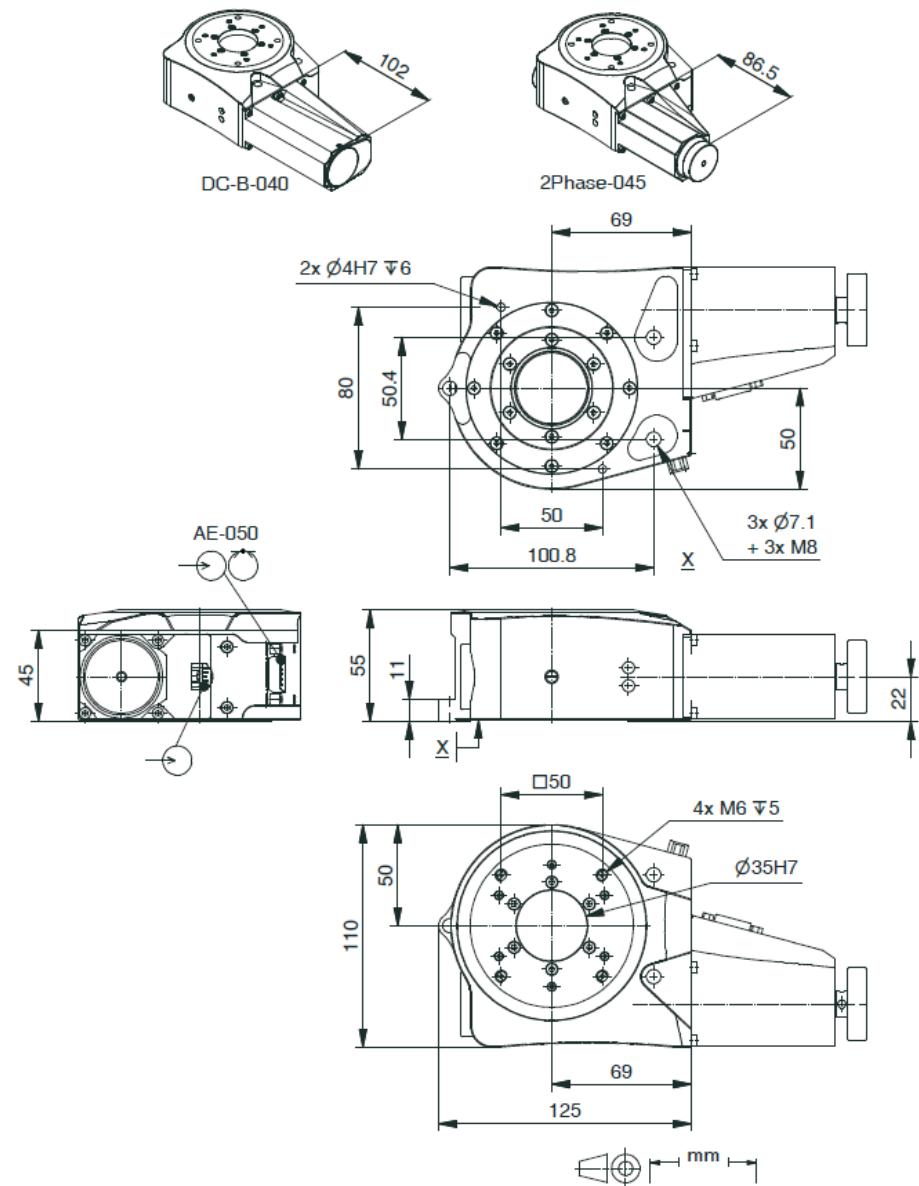

4.8 Ambient Conditions

For indoor use only.

- The PRS-110 was calibrated at an ambient temperature of 20 °C (+/- 3°C).
- The permissible operating temperature is between 20 °C and 40 °C.
- The permissible relative humidity is between 20% and 80%.
- Always keep the PRS-110 free of dirt, dust, and corrosive gases.

5. INSTALLATION

5.1 General Notes on Installation

Requirement

The axis must be screwed onto a surface with evenness better than 5 µm.

It is necessary to make sure that no dust, dirt or other foreign bodies are between the surface and the axis, otherwise the properties of the axis can be impaired by mechanical tension.

To guarantee the prescribed specifications (see Internet www.pimicos.com), the evenness of the mounting surface must be better than 5 µm. (Reference surface of PI miCos measuring granite is 3 µm).

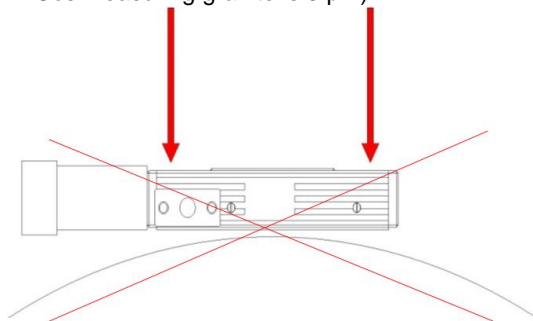

5.2 Mounting the Rotation Stage

Requirement

You have read and understood the general notes on installation (see chapter 5.1).

Mounting material

Screws, pins and auxiliary material or tools supplied (see chapter 4.5 "Scope of Delivery").

- DIN 912 screws and DIN 6325 dowel pins, m6 tolerance field

Tightening torques of the mounting screws to be used should not have values higher than the following:

- M3 DIN 912 1.5 Nm
- M4 DIN 912 2.0 Nm
- M5 DIN 912 2.5 Nm
- M6 DIN 912 3.0 Nm

Mounting the PRS-110

1. Mount the rotation stage with the screws supplied.
2. Make sure that the screw heads do not protrude from the countersunk holes.

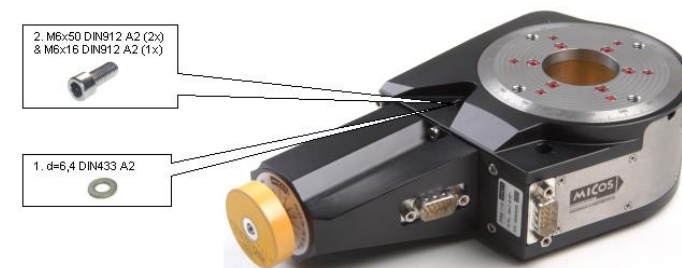

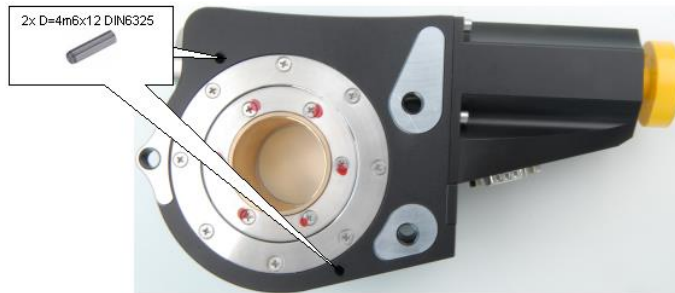

5.3 Affixing the Load

Requirement

You have read and understood the general notes on installation (see chapter 5.1).

The load must have evenness better than 5 μ m.

It is necessary to make sure that no dust, dirt or other foreign bodies are between the load and the axis, otherwise the properties of the axis can be impaired by mechanical tension.

Mounting material

- DIN 912 screws and DIN 6325 dowel pins, m6 tolerance field

Tightening torques of the mounting screws to be used should not have values higher than the following:

- M3 DIN 912 1.5 Nm
- M4 DIN 912 2.0 Nm
- M5 DIN 912 2.5 Nm
- M6 DIN 912 3.0 Nm

Mounting the Additional Part

- Select the mounting position so that the existing fixing holes in the slider of the PRS-110 can be used for the additional part to be affixed.
- Mount the additional part with the corresponding screws.

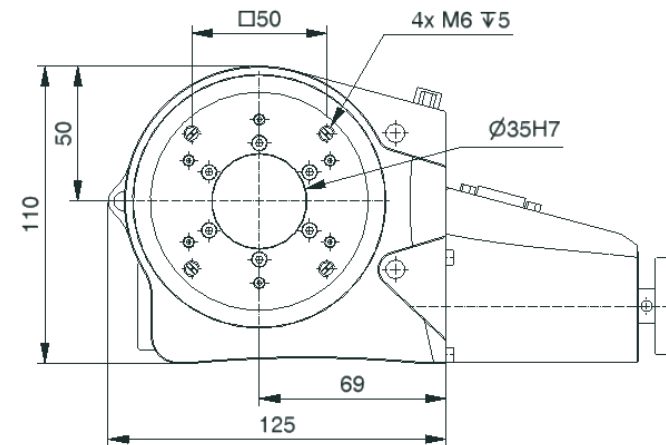

6. START-UP

6.1 General Notes on Start-Up

This rotation stage must be started up with a suitable cable and the associated controllers.

7. MAINTENANCE

Depending on the operating conditions and the period of use of the PRS-110, the following maintenance measures are required:

Maintenance Run

The maintenance run serves to distribute the existing lubricant.

- To evenly distribute the existing lubricant on the stage guidings, perform a maintenance run over one complete rotation after 500 hours of operation, or after 1 year at the latest.
- If the rotation stage is operated continuously in an industrial environment and its motion is over a small range (less than 70°), perform a maintenance run over one complete rotation after 5000 motion cycles.

Lubrication

Under laboratory conditions, extra lubrication is only necessary in exceptional cases. For continuous industrial use, the lubrication intervals must be defined individually.

- Do not lubricate the PRS-110 without consulting our customer service department (see chapter 9).
- To lubricate, follow the instructions in the maintenance manual, which you can obtain from our customer service department.

8. TROUBLESHOOTING

If the problem that occurred with your system is not listed in the table above or cannot be solved as described, contact our customer service department (see chapter 9).

9. CUSTOMER SERVICE

For inquiries and orders, contact your PI miCos sales engineer or send us an email (info@pimicos.com).

If you have questions concerning your system, have the following information ready:

1. Product codes and serial numbers of all products in the system
2. Current firmware of the controller (if present)
3. Software version of the driver or the user software (if present)
4. User operating system (if present)

10. OLD PRODUCT DISPOSAL

In accordance with EU directive 2002/96/EC (WEEE), as of 13 August 2005, electrical and electronic equipment may not be disposed of in the member states of the EU via the municipal residual waste.

Dispose of your old equipment according to international, national, and local rules and regulations.

In order to fulfil the responsibility as the product manufacturer, PI miCos GmbH undertakes environmentally correct disposal of all old PI miCos equipment made available on the market after 13 August 2005 without charge.

Any old PI miCos equipment can be sent free of charge to the following address:

PI miCos GmbH
 Freiburger Strasse 30
 79427 Eschbach, Germany
<http://www.pimicos.com>

11. EU DECLARATION OF CONFORMITY

Manufacturer:

PI miCos GmbH
 Freiburger Strasse 30



Manufacturer's Address:

79427 Eschbach, Germany
 Phone +49 7634 5057 0

The manufacturer hereby declares that the product

Product name: Precision Rotation Stage
 Type designation: PRS-110
 Item number: 6447-X-XXXXX

complies with the following European directives:

Machines (2006/42/EC)
 Electromagnetic Compatibility (2004/108/EC)
 RoHS (2011/65/EU)

The applied standards certifying the conformity are listed below:

Safety of Machinery EN 12100:2011
 Device Safety EN 61010-1:2010
 EMC Requirements EN 61326-1:2006
 RoHs DIN EN 50581:2012