

## MP127E Q-614 Miniature Rotation Stage User Manual

Version: 1.0.0

Date: 24.02.2015

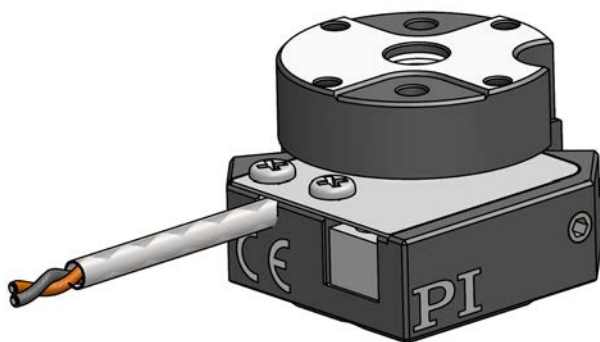

**This document describes the following product:**

- **Q-614.900**  
Q-Motion Rotation Stage, >360° Rotation Range, without Position Sensor, for Open-Loop Operation, 5 mNm Torque, 14 mm Turntable Diameter, Piezoelectric Inertia Drive



Physik Instrumente (PI) GmbH & Co. KG is the owner of the following trademarks: PI®, PIC®, PICMA®, PLine®, PIFOC®, PiezoWalk®, NEXACT®, NEXLINE®, NanoCube®, NanoAutomation®, Picoactuator®, PInano®

© 2015 Physik Instrumente (PI) GmbH & Co. KG, Karlsruhe, Germany. The text, photographs and drawings in this manual are protected by copyright. With regard thereto, Physik Instrumente (PI) GmbH & Co. KG retains all the rights. Use of said text, photographs and drawings is permitted only in part and only upon citation of the source.

Original instructions

First printing: 24.02.2015

Document number: MP127E, KSch, version 1.0.0

Subject to change without notice. This manual is superseded by any new release. The latest release is available for download (p. 3) on our website.



# Contents

<b>1</b>	<b>About this Document</b>	<b>1</b>
1.1	Goal and Target Audience of this User Manual .....	1
1.2	Symbols and Typographic Conventions .....	1
1.3	Definition .....	2
1.4	Figures .....	2
1.5	Other Applicable Documents .....	3
1.6	Downloading Manuals .....	3
<b>2</b>	<b>Safety</b>	<b>5</b>
2.1	Intended Use .....	5
2.2	General Safety Instructions .....	5
2.3	Organizational Measures .....	6
<b>3</b>	<b>Product Description</b>	<b>7</b>
3.1	Product View .....	7
3.2	Product Labeling .....	8
3.3	Scope of Delivery .....	9
3.4	Suitable Drive Electronics .....	9
<b>4</b>	<b>Unpacking</b>	<b>11</b>
<b>5</b>	<b>Installation</b>	<b>13</b>
5.1	General Notes on Installation .....	13
5.2	Mounting the Q-614 on a Surface and Connecting It to a Protective Earth Conductor .....	14
5.3	Setting Up a Multi-Axis System .....	18
5.4	Affixing the Load to the Q-614 .....	19
5.5	Connecting the Q-614 to the Drive Electronics .....	21
<b>6</b>	<b>Start-Up and Operation</b>	<b>23</b>
6.1	General Notes on Start-Up and Operation .....	23
6.2	Starting Up the Rotation Stage .....	26
6.3	Operating Parameters of the Q-614 .....	27

7	Maintenance	29
7.1	General Notes on Maintenance	29
7.2	Performing a Maintenance Run	29
7.3	Cleaning the Q-614	29
8	Troubleshooting	31
9	Customer Service	33
10	Technical Data	35
10.1	Specifications	35
10.1.1	Data Table	35
10.1.2	Maximum Ratings	36
10.1.3	Ambient Conditions and Classifications	37
10.2	Operating Time	37
10.3	Dimensions	38
10.4	Pin Assignment	39
11	Old Equipment Disposal	41
12	EC Declaration of Conformity	43

# 1 About this Document

## In this Chapter

Goal and Target Audience of this User Manual .....	1
Symbols and Typographic Conventions .....	1
Definition .....	2
Figures .....	2
Other Applicable Documents .....	3
Downloading Manuals .....	3

## 1.1 Goal and Target Audience of this User Manual

This user manual contains the information needed for the intended use of the Q-614.

Basic knowledge of motion control concepts and applicable safety measures is assumed.

The latest versions of the user manuals are available for download (p. 3) on our website.

## 1.2 Symbols and Typographic Conventions

The following symbols and typographic conventions are used in this user manual:

### **CAUTION**



#### **Dangerous situation**

If not avoided, the dangerous situation will result in minor injury.



- Actions to take to avoid the situation.

### **NOTICE**



#### **Dangerous situation**

If not avoided, the dangerous situation will result in damage to the equipment.

- Actions to take to avoid the situation.

### **INFORMATION**

Information for easier handling, tricks, tips, etc.

<b>Symbol/Label</b>	<b>Meaning</b>
1.	Action consisting of several steps whose sequential order must be observed
2.	
➤	Action consisting of one or several steps whose sequential order is irrelevant
▪	List item
p. 5	Cross-reference to page 5
RS-232	Labeling of an operating element on the product (example: socket of the RS-232 interface)
	Warning sign on the product which refers to detailed information in this manual.

## 1.3 Definition

<b>Term</b>	<b>Explanation</b>
Load capacity	Maximum load capacity in the vertical direction when the rotation stage is mounted horizontally. The contact point of the load is in the center of the platform.

## 1.4 Figures

For better understandability, the colors, proportions and degree of detail in illustrations can deviate from the actual circumstances. Photographic illustrations may also differ and must not be seen as guaranteed properties.

## 1.5 Other Applicable Documents

The devices and software tools which are mentioned in this documentation are described in their own manuals.

Description	Document
E-870.10, E-870.11, E-870.21, E-870.41 Piezomotor / PiezoMike Drive Electronics, OEM Board, 1 to 4 Channels	E870T0001 Technical Note
E-870.1G, E-870.2G, E-870.4G Piezomotor / PiezoMike Drive Electronics, Bench-Top, 1 to 4 Channels	E870T0002 Technical Note

## 1.6 Downloading Manuals

### INFORMATION

If a manual is missing or problems occur with downloading:

- Contact our customer service department (p. 33).

### INFORMATION

For some products (e.g. Hexapod systems and electronics that are delivered with a CD), access to the manuals is password-protected. The password is stored on the CD. Availability of the manuals:

- Password-protected manuals: FTP download directory
- Freely available manuals: PI website
- Follow the corresponding instructions for downloading.

### Download freely accessible manuals

1. Open the website <http://www.pi-portal.ws>.
2. Click **Downloads**.
3. Click the corresponding product category.
4. Go to the corresponding product code.

The available manuals are displayed.

5. Click the desired manual and save it on the hard disk of your PC or on a data storage medium.

### **Download password-protected manuals**

1. Insert the product CD in the PC drive.
2. Switch to the Manuals directory on the CD.
3. In the Manuals directory, open the Release News (file including *releasenews* in the file name).
4. Find the user name and the password in the section "User login for software download" in the Release News.
5. Open the FTP download directory (ftp://pi-ftp.ws).
  - Windows operating systems: Open the FTP download directory in Windows Explorer.
6. Log in with the user name and the password from the Release News.
7. In the directory of the corresponding product, go to the Manuals sub-directory.
8. Copy the desired manual to the hard disk of your PC or to a data storage medium.



## 2 Safety

### In this Chapter

Intended Use .....	5
General Safety Instructions .....	5
Organizational Measures.....	6

### 2.1 Intended Use

The Q-614 is a laboratory device as defined by DIN EN 61010-1. It is intended to be used in interior spaces and in an environment which is free of dirt, oil and lubricants.

In accordance with its design and realization, the Q-614 is intended for positioning, adjusting and rotation of loads in a rotational axis at different velocities in interval operation. The Q-614 uses a PIShift piezomotor as a drive. When at rest, the drive is self-locking, requires no current, generates no heat, and maintains its position.

The Q-614 can be mounted in any orientation. The specifications of the Q-614 apply to horizontal mounting (p. 35).

The Q-614 is **not** intended for applications in areas in which a failure would present severe risks to human beings or the environment. The Q-614 is not intended for continuous operation. For further information on the operating conditions of the Q-614, see "Technical Data" (p. 35).

The intended use of the Q-614 is only possible in combination with suitable drive electronics that provides the required operating voltages. The drive electronics is not in the scope of delivery of the Q-614. PI offers suitable drive electronics (see p. 9).

### 2.2 General Safety Instructions

The Q-614 is built according to state-of-the-art technology and recognized safety standards. Improper use can result in personal injury and/or damage to the Q-614.

- Only use the Q-614 for its intended purpose, and only use it if it is in a good working order.
- Read the user manual.
- Immediately eliminate any faults and malfunctions that are likely to affect safety.

The operator is responsible for the correct installation and operation of the Q-614.

## 2.3 Organizational Measures

### User manual

- Always keep this user manual available by the Q-614.  
The latest versions of the user manuals are available for download (p. 3) on our website.
- Add all information given by the manufacturer to the user manual, for example supplements or Technical Notes.
- If you pass the Q-614 on to other users, also turn over this user manual as well as other relevant information provided by the manufacturer.
- Only use the device on the basis of the complete user manual. Missing information due to an incomplete user manual can result in minor injury and property damage.
- Only install and operate the Q-614 after having read and understood this user manual.

### Personnel qualification

The Q-614 may only be installed, started up, operated, maintained and cleaned by authorized and appropriately qualified personnel.

### 3 Product Description

#### In this Chapter

Product View .....	7
Product Labeling.....	8
Scope of Delivery .....	9
Suitable Drive Electronics.....	9

#### 3.1 Product View

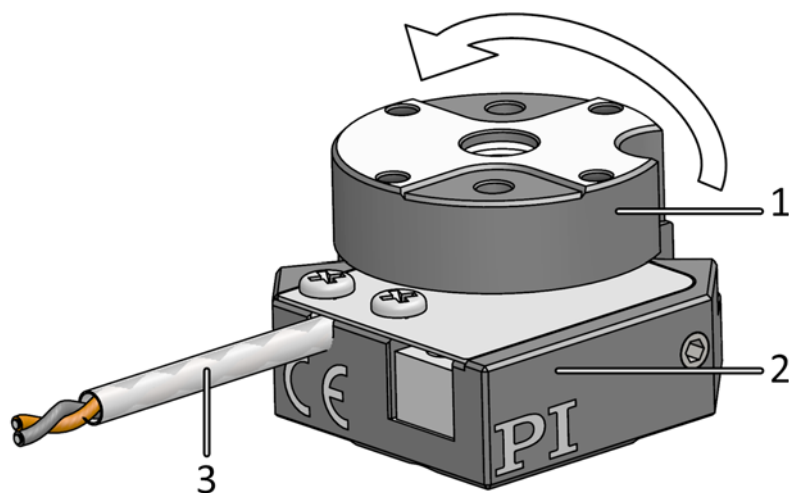

Figure 1: Q-614 product view

- 1 Moving platform
- 2 Base body
- 3 Motor cable for connection to the electronics

The arrow in the figure shows the positive direction of motion.

### 3.2 Product Labeling

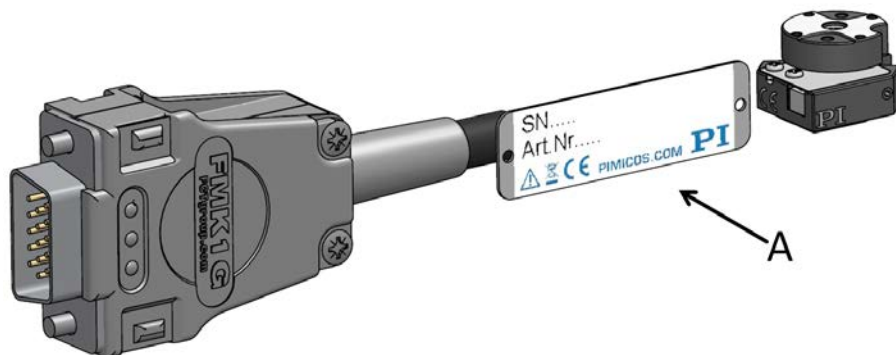

Figure 2: Type plate of the Q-614: Position of the product labeling (example view)

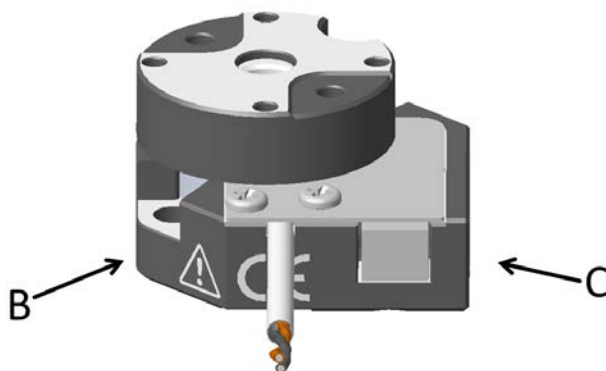





Figure 3: Q-614: Position of the product labeling (example view)

Position	Labeling	Description
A	113064246	Serial number (example), individual for each Q-614 Meaning of the places (counting from left): 1 = internal information, 2 and 3 = manufacturing year, 4 to 9 = consecutive numbers
A	Q-614.900	Product name
A, B		Warning sign "Observe manual!"
A		Old equipment disposal (p. 41)

Position	Labeling	Description
A, B		CE conformity mark
A	WWW.PIMICOS.COM	Manufacturer's address (website)
A, C		Manufacturer's logo
B		Symbol for the protective earth conductor, marks the position of the holes via which the Q-614 is to be connected to the protective earth conductor

### 3.3 Scope of Delivery

Item ID	Components
Q-614	Rotation stage according to order
RPS14.5002	Screw set for mounting the Q-614, consisting of: <ul style="list-style-type: none"> <li>▪ 2 1.5 m6 x 3 A2 dowel pins ISO 8734</li> <li>▪ 2 M2x6 A2 socket head cap screws ISO 4762</li> </ul>
7202500042-0015	Adapter cable for connection to the E-870 drive electronics, Sub-D 15 (f) to Mini-DIN 4 (m), 0.3 m
MP127E	Manual for Q-614 rotation stage

### 3.4 Suitable Drive Electronics

Order number	Description
E-870.10	PIShift Piezomotor / PiezoMike Drive Electronics, 1 Channel, OEM Board
E-870.11	PIShift Piezomotor / PiezoMike Drive Electronics, 1 Channel, OEM Board with Connector Strip
E-870.1G	PIShift Piezomotor / PiezoMike Drive Electronics, 1 Channel, Bench-Top Device
E-870.21	PIShift Piezomotor / PiezoMike Drive Electronics, 2 Channels, OEM Board with Connector Strip

Order number	Description
E-870.2G	PIShift Piezomotor / PiezoMike Drive Electronics, 2 Channels, Bench-Top Device
E-870.41	PIShift Piezomotor / PiezoMike Drive Electronics, 4 Channels, OEM Board with Connector Strip
E-870.4G	PIShift Piezomotor / PiezoMike Drive Electronics, 2 Channels, Bench-Top Device

- To order, contact our customer service department (p. 33).

## 4 Unpacking

1. Unpack the Q-614 with care.
2. Compare the contents against the items covered by the contract and against the packing list.
3. Inspect the contents for signs of damage. If parts are missing or you notice signs of damage, contact PI immediately.
4. Keep all packaging materials in case the product needs to be returned.





## 5 Installation

### In this Chapter

General Notes on Installation .....	13
Mounting the Q-614 on a Surface and Connecting It to a Protective Earth Conductor .....	14
Setting Up a Multi-Axis System .....	18
Affixing the Load to the Q-614.....	19
Connecting the Q-614 to the Drive Electronics .....	21

### 5.1 General Notes on Installation

#### NOTICE



##### Heating up of the Q-614 during operation!

The heat produced during operation of the Q-614 can affect your application.

- Install the Q-614 so that the application is not impaired by the dissipated heat.
- Ensure sufficient ventilation at the place of installation.
- Make sure that the complete bottom side of the Q-614 is in contact with the surface on which the Q-614 is mounted.

#### NOTICE



##### Unintentional changes in position with vertical mounting!

If the load exceeds the maximum torque of the drive when the rotation stage is mounted vertically, unintentional changes in the position of the moving platform occur. Unintentional changes in position of the moving platform can damage the drive, the load or the environment.

- When a rotation stage is mounted vertically, make sure that the installed load is lower than the maximum torque of the drive (p. 35).

**NOTICE****Lubricants, dirt, condensation!**

Dirt, oil, lubricants and condensation will render the motor/drive inoperable.

- Keep the Q-614 free from lubricants.
- Keep the Q-614 free from dirt and condensation.

**NOTICE****Damage from unsuitable cables!**

Unsuitable cables can damage the electronics.

- Only use cables provided by PI for connecting the Q-614 to the electronics.

**INFORMATION**

The positive direction of motion is a counterclockwise rotation.

## 5.2 Mounting the Q-614 on a Surface and Connecting It to a Protective Earth Conductor

**NOTICE****Protruding screw heads!**

Protruding screw heads can damage the Q-614.

- Ensure that the screw heads do not protrude from counter-sunk holes so that they do not interfere with the stage motion.

**NOTICE****Warping of the Q-614 due to mounting on uneven surfaces!**

Mounting the Q-614 on an uneven surface can warp the Q-614. Warping reduces the accuracy.

- Mount the Q-614 on an even surface. The recommended evenness of the surface is  $\leq 2 \mu\text{m}$ .
- For applications with great temperature changes:  
Only mount the Q-614 on surfaces that have the same or similar thermal expansion properties as the Q-614.

**INFORMATION**

The contact of the Q-614 with the protective earth conductor is made as follows:

- Two counter-sunk holes in the base body of the Q-614
- Suitable conductive screws (p. 9)
- Protective earth conductor connected to the surface on which the Q-614 is mounted

**INFORMATION**

- Observe the applicable standards for mounting the protective earth conductor.

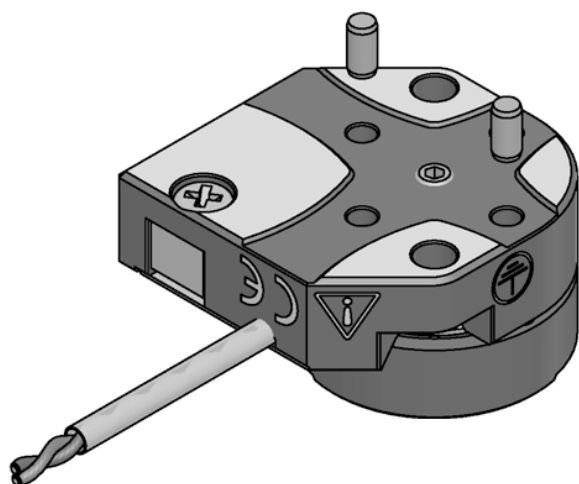

Figure 4: Bottom side of the Q-614: Two of the four available locating holes can be used for alignment on a surface

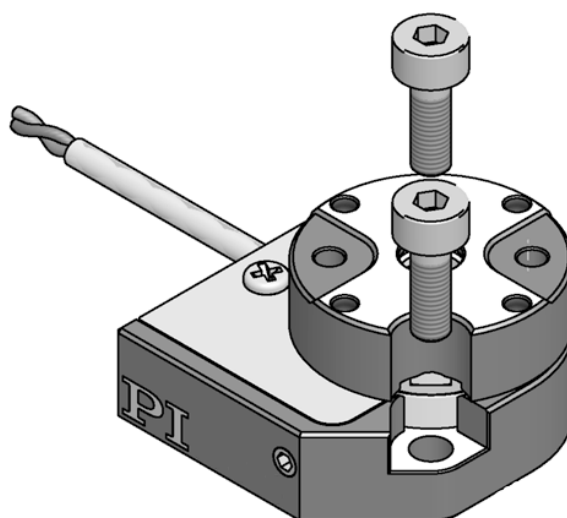

Figure 5: Top side of the Q-614: The Q-614 is mounted on a surface with two screws

### Prerequisites

- ✓ You have read and understood the general notes on installation (p. 13).
- ✓ The Q-614 is **not** connected to the drive electronics.
- ✓ You have provided a suitable surface (for the required position and depth of the holes for accommodating the screws and locating pins, see "Dimensions" (p. 38)):
  - The surface must be connected to the protective earth conductor.
  - Two locating pins with  $\varnothing 1.5$  mm H7 and two M2 mounting holes are available in the surface.
  - The holes for accommodating the screws have to be sufficiently conductive to ensure the proper functioning of the protective earth conductor.
  - For applications with great temperature changes: The surface should have the same or similar thermal expansion properties as the Q-614 (e.g. surface made of aluminum).

- The evenness of the surface is  $\leq 2 \mu\text{m}$ .
- ✓ You have accounted for the space required for a cable routing free of kinks and in accordance with regulations.

### Tools and accessories

- RPS14.5002 screw set from the scope of delivery of the Q-614 (p. 9):
  - 2 1.5 m6 x 3 dowel pins ISO 8734 for use as locating pins
  - 2 M2x6 socket head cap screws ISO 4762
- Suitable screwdriver

### Mounting the Q-614 on a surface and connecting it to the protective earth conductor

1. Introduce the two locating pins into the locating holes on the bottom side of the Q-614 (see figure above) or in the surface.
2. Place the Q-614 on the surface so that the locating pins are inserted into the corresponding locating holes on the other side.
3. Mount the Q-614 on the surface with two M2 screws:
  - a) Manually turn the moving platform of the Q-614 until one of the two counter-sunk holes in the base body is accessible.
  - b) Introduce the screw into the counter-sunk hole.
  - c) Tighten the screw with a maximum torque of 35 Ncm.
  - d) Make sure that the screw head does not protrude from the counter-sunk hole.
  - e) Repeat the steps a) to d) for the other counter-sunk hole in the base body of the Q-614.
4. Make sure that the contact resistance at all connection points relevant for mounting the protective earth conductor is  $< 0.1 \Omega$  at 25 A.
5. Check that the Q-614 fits on the surface without backlash.

## 5.3 Setting Up a Multi-Axis System

In a stacked X- $\theta$ Z system, the Q-614 can be mounted as a  $\theta$ Z axis on a Q-522 (X axis).

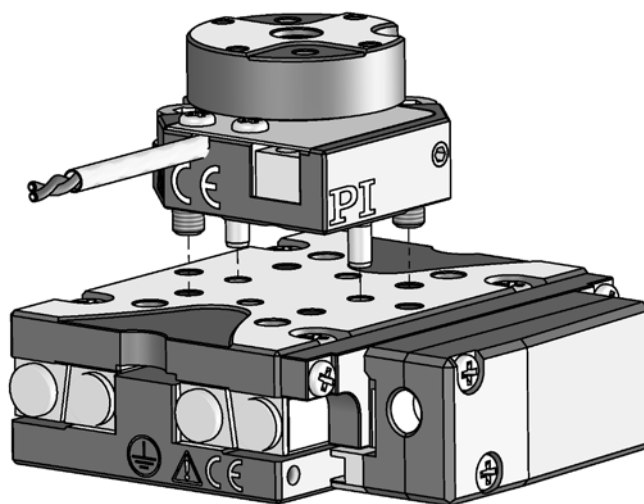

Figure 6: Mounting a Q-614 on a Q-522

### Prerequisites

- ✓ You have read and understood the general notes on installation (p. 13).
- ✓ The stages are disconnected from the electronics.
- ✓ You have properly mounted the Q-522 stage on a surface and connected it to a protective earth conductor (see user manual of the Q-522).
- ✓ You have accounted for the space required for a cable routing free of kinks and in accordance with regulations.

### Tools and accessories

- RPS14.5002 screw set from the scope of delivery of the Q-614 (p. 9):
  - 2 1.5 m6 x 3 dowel pins ISO 8734 for use as locating pins
  - 2 M2x6 socket head cap screws ISO 4762
- Suitable screwdriver

### Setting up a multi-axis system

1. Insert the two locating pins into the selected locating holes on the bottom side of the Q-614 or in the moving platform of the Q-522 (see figure above).
2. Place the Q-614 on the Q-522 so that the locating pins are inserted into the corresponding locating holes on the other side.
3. Mount the Q-614 on the Q-522 with two M2 screws:
  - a) Manually turn the moving platform of the Q-614 until one of the two counter-sunk holes in the base body is accessible.
  - b) Introduce the screw into the counter-sunk hole.
  - c) Tighten the screw with a maximum torque of 35 Ncm.
  - d) Make sure that the screw head does not protrude from the counter-sunk hole.
  - e) Repeat the steps a) to d) for the other counter-sunk hole in the base body of the Q-614.
4. Check that the Q-614 fits on the Q-522 without backlash.

## 5.4 Affixing the Load to the Q-614

### NOTICE



#### Impermissibly high forces and torques!

Impermissibly high forces and torques that are applied to the moving platform can damage the Q-614.

- For affixing type and mass of the load, observe the maximum permissible forces according to the specifications (p. 35).
- Avoid tilting torques at the moving platform.

### NOTICE



#### Screws that are too long!

The Q-614 can be damaged by screws that are too long.

- Note the depth of the mounting holes in the moving platform (p. 38).
- Only use screws of the correct length for the respective mounting holes.

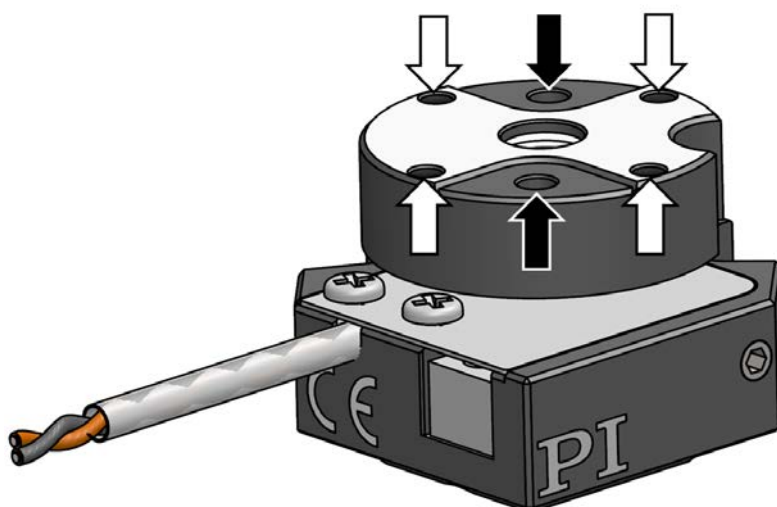

Figure 7: Black arrows indicate locating holes for alignment of the load, whereas white arrows indicate threaded holes for affixing the load

### Prerequisites

- ✓ You have read and understood the general notes on installation (p. 13).
- ✓ You have properly mounted the Q-614 on a surface (p. 14) or on a Q-522 stage (p. 18).
- ✓ The Q-614 is **not** connected to the drive electronics.
- ✓ You have prepared the load so that it can be affixed to the moving platform (for the required position and depth of the holes for accommodating the screws and locating pins, see "Dimensions" (p. 38)):
  - The distance between the center of gravity of the load and the center of the moving platform is as small as possible in all directions.
  - Four points are provided for affixing the load to the moving platform.
  - If you use locating pins for aligning the load: You have made two locating holes of  $\varnothing 1.5$  mm H7 in the load for accommodating locating pins.

### Tools and accessories

- 4 M1.6 screws of suitable length (p. 38)
- Suitable tools for fastening the screws
- Optional: 2 locating pins of suitable length, for locating holes with  $\varnothing 1.5$  mm H7



### Affixing the load to the Q-614

1. Align the load on the Q-614 so that the mounting holes in the load and the holes in the moving platform overlap.

If you use locating pins to align the load:

- a) Insert the locating pins into the locating holes in the moving platform or the load.
  - b) Place the load on the moving platform so that the locating pins are inserted into the corresponding locating holes on the other side.
2. Affix the load using the screws.
    - Maximum torque: 17 Ncm.
  3. Check that the load fits on the moving platform of the Q-614 without backlash.

## 5.5 Connecting the Q-614 to the Drive Electronics

### INFORMATION

The Q-614 and the drive electronics can be delivered as a pre-configured system.

- If a connection assignment is given on the labels of the Q-614 and/or drive electronics, observe this assignment when connecting the Q-614.

### Prerequisites

- ✓ You have read and understood the general notes on installation (p. 13).
- ✓ You have installed the E-870 drive electronics.
- ✓ You have read and understood the user manual of the drive electronics.
- ✓ The drive electronics is **not** connected to the supply voltage.

### Tools and accessories

- If the drive electronics has a Mini-DIN 4 socket (models: E-870.x1, E-870.xG): 7202500042-0015 adapter cable, included in the scope of delivery (p. 9)
- If the drive electronics has a connector strip (model E-870.10): Suitable adapter from Sub-D 15 (f) to the connector strip:
  - The pin assignment of the J10 connector strip (2x4 pin) can be found in the E870T0001 Technical Note.

- If you need a suitable adapter, contact our customer service department (p. 33).

### **Connecting the Q-614 to E-870 drive electronics with a Mini-DIN 4 socket**

1. Connect the Q-614 with the adapter cable:
  - Connect the Sub-D 15 (m) connector of the Q-614 with the connector of the adapter cable (Sub-D 15 (f)).
2. Connect the adapter cable with the drive electronics:
  - Connect the Mini-DIN 4 connector of the adapter cable with the Mini-DIN 4 socket of the drive electronics.
3. Take suitable measures to prevent the adapter cable from being accidentally disconnected.

### **Connecting the Q-614 to E-870 drive electronics with a connector strip**

- Connect the Q-614 to the connector strip of the drive electronics with a suitable adapter.

## 6 Start-Up and Operation

### In this Chapter

General Notes on Start-Up and Operation .....	23
Starting Up the Rotation Stage.....	26
Operating Parameters of the Q-614 .....	27

### 6.1 General Notes on Start-Up and Operation

#### CAUTION



#### Risk of electric shock if the protective earth conductor is not connected!

If a protective earth conductor is not or not properly connected, dangerous touch voltages can occur on the Q-614 in the case of malfunction or failure of the system. If touch voltages exist, touching the Q-614 can result in minor injuries from electric shock.

- Connect the Q-614 to a protective earth conductor (p. 14) before start-up.
- Do **not** remove the protective earth conductor during operation.
- If the protective earth conductor has to be removed temporarily (e. g. in the case of modifications), reconnect the Q-614 to the protective earth conductor before starting it up again.

#### CAUTION



#### Burning from hot surface!

The surface of the Q-614 and its vicinity can heat up during operation. Touching the Q-614 and surrounding parts can result in minor injuries from burning.

- Cool the Q-614 so that the temperature of its surface and surrounding parts does **not** exceed 65 °C.
- If sufficient cooling is not possible: Make sure that the hot Q-614 and its surrounding parts **cannot** be touched.
- If sufficient cooling and protection against contact are not possible: Mark the danger zone in accordance with the legal regulations.

**NOTICE****Overheating during continuous operation!**

The highest velocity is achieved at maximum operating frequency; however, the Q-614 can overheat during continuous operation as a result.

- Observe the recommended operating time according to the operating frequency in step mode (p. 37).
- Ensure sufficient ventilation at the place of installation.

**NOTICE****Operating voltage too high or incorrectly connected!**

Operating voltages that are too high or incorrectly connected can cause damage to the Q-614.

- Only operate the Q-614 with controllers/drivers and original accessories from PI.
- Do **not** exceed the operating voltage range (p. 36) for which the Q-614 is specified.
- Only operate the Q-614 when the operating voltage is properly connected; see "Pin Assignment" (p. 39).

**NOTICE****Operating frequency too high!**

An operating frequency that is too high can cause damage to the Q-614.

- Only operate the Q-614 with controllers/drivers and original accessories from PI.
- Do **not** exceed the operating frequency range (p. 36) for which the Q-614 is specified.

**NOTICE****Reduced lifetime of the piezo actuator due to permanently high voltage!**

The permanent application of a high static voltage to piezo actuators leads to a considerable reduction in the lifetime of the piezo ceramic of the rotation stage.

- When the Q-614 is not used, switch off the electronics.

**NOTICE****Destruction of the piezo actuator by electric flashovers!**

The use of the Q-614 in environments that increase the electrical conductivity can lead to the destruction of the piezo actuator by electric flashovers. Electric flashovers can be caused by moisture, high humidity, liquids and conductive materials such as metal dust. In addition, electric flashovers can also occur in certain air pressure ranges due to the increased conductivity of the air.

- Avoid operating the Q-614 in environments that can increase the electric conductivity.
- Only operate the Q-614 within the permissible ambient conditions and classifications (p. 37).

**NOTICE****Damage from collisions!**

Collisions can damage the rotation stage, the load to be moved and the environment.

- Make sure that no collisions are possible between the rotation stage, the load to be moved and the environment in the motion range of the rotation stage.
- Do not place any objects in areas where they can get caught by moving parts.
- Stop the motion immediately if an electronics malfunction occurs.

**NOTICE****Considerable wear due to high operating frequency!**

A high operating frequency in step mode can cause considerable wear on the mechanical system.

- Reduce the value of the **PIShift Steps per Second** parameter (ID 0x1F000600) and the **PIShift Frequency** parameter (ID 0x1F000400) on the drive electronics; see user manual of the electronics.
- Reduce the operating time with a high operating frequency (p. 37).
- Stop the motion immediately if an electronics malfunction occurs.

**NOTICE****Increased wear due to small working range!**

- If you only move the Q-614 over a small working range (<math><20^\circ</math>), perform at least one full rotation of the moving platform at regular intervals.

**INFORMATION**

The drive electronics is adapted via parameters to the Q-614. Changing parameter values can cause undesirable results.

- Only operate the Q-614 when the parameters of the drive electronics have been correctly set, see "Operating Parameters of the Q-614" (p. 27).

**INFORMATION**

The PIShift drive develops noises in step mode. The noise development depends on the current step frequency.

## 6.2 Starting Up the Rotation Stage

**INFORMATION**

If the parameters of the drive electronics are not adapted to the Q-614 and the application (load, orientation of the Q-614), the Q-614 will either not move or not move satisfactorily.

- Only operate the Q-614 when the parameters of the drive electronics have been correctly set, see "Operating Parameters of the Q-614" (p. 27).
- Pay particular attention to the parameter settings for operating voltage and operating frequency.

**INFORMATION**

The values of the **PIShift Steps per Second** parameter (ID 0x1F000600) and the **PIShift Frequency** parameter (ID 0x1F000400) should be identical for optimum drive performance. Further information can be found in the user manual of the electronics.

### Prerequisites

- ✓ You have read and understood the general notes on start-up and operation (p. 23).
- ✓ The Q-614 has been installed properly (p. 13).
- ✓ The E-870 drive electronics has been properly installed, and all connections on the E-870 have been set up (see E870T0001 Technical Note or E870T0002 Technical Note).

### Starting up the Q-614 with E-870 drive electronics

1. Make sure that the parameters of the E-870 drive electronics have been correctly set, see "Operating Parameters of the Q-614" (p. 27).
2. Provide the control signal required for operating the system. Details can be found in the E870T0001 or E870T0002 Technical Note.
3. If necessary: Adapt the **PIShift Steps per Second** parameter (ID 0x1F000600) and the **PIShift Frequency** parameter (ID 0x1F000400) to your application (see also "Operating Time" (p. 37)).

## 6.3 Operating Parameters of the Q-614

The following table lists the settings for the parameters of the E-870 drive electronics. Further information on the parameter settings is found in the "Operating Time" section (p. 37).

Parameter	Parameter in E-870 Drive Electronics	Value	Unit
Operating voltage, upper limit	<b>PIShift Upper Supply Voltage</b> ID 0x1F000000	48	V
Operating voltage, lower limit	<b>PIShift Lower Supply Voltage</b> ID 0x1F000100	0	V
Charging current during forward motion	<b>PIShift Forward Current</b> ID 0x1F000200	0.2	A
Charging current during backward motion	<b>PIShift Backward Current</b> ID 0x1F000300	-0.2	A
Operating frequency in step mode	<b>PIShift Frequency</b> ID 0x1F000400	20000	Hz
Duty cycle of the current source during the output of one period of the modified sawtooth signal in step mode	<b>PIShift Charge Cycle</b> ID 0x1F000500	1	-

Parameter	Parameter in E-870 Drive Electronics	Value	Unit
Number of steps that the rotation stage moves per second with the set operating frequency.	<b><i>PIShift Steps per Second</i></b> ID 0x1F000600	20000	



# 7 Maintenance

## In this Chapter

General Notes on Maintenance.....	29
Performing a Maintenance Run.....	29
Cleaning the Q-614 .....	29

## 7.1 General Notes on Maintenance

### NOTICE



#### Damage due to improper maintenance!

Improper maintenance can lead to misalignment and failure of the Q-614.

- Only loosen screws according to the instructions in this manual.

## 7.2 Performing a Maintenance Run

The maintenance run must comprise at least one full rotation of the moving platform of the Q-614.

- Perform the maintenance run after every 10 million steps.

## 7.3 Cleaning the Q-614

### Prerequisites

- ✓ You have disconnected the rotation stage from the electronics.

### Cleaning the rotation stage

- When necessary, clean the surfaces of the rotation stage with a cloth that is lightly dampened with a mild cleanser or disinfectant.
- Do **not** use any organic solvents.



## 8 Troubleshooting

Problem	Possible Causes	Solution
Functional impairment after system modification	<ul style="list-style-type: none"> <li>▪ Drive electronics has been replaced</li> <li>▪ The rotation stage has been replaced</li> </ul>	Drive electronics from PI: <ul style="list-style-type: none"> <li>➤ Set the parameters in the E-870 Control PC program so that they correspond to the combination of drive electronics and Q-614 model (for details, see "Operating Parameters of the Q-614" (p. 27) and E870T0001 or E870T0002 Technical Note).</li> </ul>
No or limited motion	The cable is not connected correctly or is defective	<ul style="list-style-type: none"> <li>➤ Check the connecting cable</li> </ul>
	Excessive load	<ul style="list-style-type: none"> <li>➤ Reduce the load. Observe the information in the "Technical Data" section (p. 35).</li> <li>➤ When a rotation stage is mounted vertically, make sure that the installed load is lower than the maximum torque of the drive.</li> </ul>
	Parameters of the drive electronics incorrectly set	<ul style="list-style-type: none"> <li>➤ Check the settings for the parameters of the drive electronics (for details, see "Operating Parameters of the Q-614" (p. 27) and E870T0001 or E870T0002 Technical Note).</li> </ul>
	Operating voltage too low	<ul style="list-style-type: none"> <li>➤ Provide an operating voltage of 48 V.</li> </ul>
	Unfavorable operating frequency for step mode	<ul style="list-style-type: none"> <li>➤ Adapt the operating frequency for the step mode (for details, see "Starting Up the Rotation Stage" (p. 26) and E870T0001 or E870T0002 Technical Note).</li> </ul>
	Warped base body	<ul style="list-style-type: none"> <li>➤ Mount the Q-614 on an even surface. The recommended evenness of the surface is 2 µm.</li> </ul>

Problem	Possible Causes	Solution
	Unfavorable load mounting	<ul style="list-style-type: none"> <li>➤ Observe the maximum torque when affixing the load (p. 19).</li> <li>➤ The distance between the center of gravity of the load and the center of the moving platform is as small as possible in all directions.</li> </ul>
	Unsuitable ambient conditions	<ul style="list-style-type: none"> <li>➤ Only operate the Q-614 in a clean environment and within the permissible ambient conditions (p. 37).</li> </ul>
	Wear of the drive	<ul style="list-style-type: none"> <li>➤ Replace the Q-614 and make sure that the operating parameters of the electronics are adapted to the rotation stage.</li> </ul>
	Drive is blocked	<ul style="list-style-type: none"> <li>➤ Carefully release the blockage by manually turning the moving platform back and forth.</li> <li>➤ Contact our customer service department (p. 33).</li> </ul>

If the problem that occurred with your system is not listed in the table above or cannot be solved as described, contact our customer service department (p. 33).

## 9 Customer Service

For inquiries and orders, contact your PI sales engineer or send us an e-mail ([info@pi.ws](mailto:info@pi.ws)).

If you have questions concerning your system, have the following information ready:

- Product codes and serial numbers of all products in the system
- Firmware version of the controller (if present)
- Version of the driver or the software (if present)
- Operating system on the PC (if present)

The latest versions of the user manuals are available for download (p. 3) on our website.



## 10 Technical Data

### In this Chapter

Specifications .....	35
Operating Time.....	37
Dimensions.....	38
Pin Assignment.....	39

## 10.1 Specifications

### 10.1.1 Data Table

Preliminary Data	Q-614.900	Unit	Tolerance
<b>Motion and positioning</b>			
Active axis	$\theta_z$		
Rotation range	>360	°	
Resolution	1*	$\mu$ rad	
Min. incremental motion	100*	$\mu$ rad	typ.
Maximum velocity, open-loop	70	°/s	
<b>Mechanical properties</b>			
Load capacity	1	N	
Holding torque, de-energized	6	mNm	min.
Torque	5	mNm	typ.
Length	18	mm	
Width	18	mm	
Height	10	mm	
Turntable diameter	14	mm	

Preliminary Data	Q-614.900	Unit	Tolerance
<b>Drive properties</b>			
Motor type	Piezoelectric inertia drive		
<b>Miscellaneous</b>			
Operating temperature range	0 to 40	°C	
Material	Aluminum		
Mass without cable	9	g	
Cable length	1	m	
Connector	Sub-D		
Recommended controller	E-870		

Ask about custom designs!

\* Open-loop

The Q-614 stage series replaces the RPS-14 series.

The specifications were determined on a surface with an evenness of 2 µm.

### 10.1.2 Maximum Ratings

The Q-614 rotation stage is designed for the following operating data:

Maximum Operating Voltage	Maximum Operating Frequency	Maximum Power Consumption
48 V	20 kHz	10 W



### 10.1.3 Ambient Conditions and Classifications

The following ambient conditions and classifications must be observed for the Q-614:

Area of application	For indoor use only
Maximum altitude	2000 m
Air pressure	1100 hPa to 0.1 hPa (corresponds to roughly 825 Torr to 0.075 Torr)
Relative humidity	Highest relative humidity 80 % for temperatures up to 31 °C Decreasing linearly to 50 % relative humidity at 40 °C
Operating temperature	0°C to 40°C
Storage temperature	-20 °C to 70 °C
Transport temperature	-20 °C to 70 °C
Overvoltage category	II
Protection class	I
Degree of pollution	1
Degree of protection according to IEC 60529	IP20

## 10.2 Operating Time

The operating time and the operating frequency in step mode affect the lifetime of the rotation stage. In order to prevent overheating and high wear, the operating time with the given operating frequency and 100 % duty cycle must not exceed the values given in the following table.

Operating Frequency in Hz <sup>1</sup>	Operating Time <sup>2</sup> / 48 V, ±0.2 A
20000	10 s (max.)
10000	20 s (max.)
5000	60 s (max.)
≤ 1000	120 s (max.)

<sup>1</sup> For the relevant parameters see "Starting Up the Rotation Stage" (p. 26) and the user manual of the electronics used.

<sup>2</sup> With 100 % duty cycle without heat dissipation

### 10.3 Dimensions

Dimensions in mm

Signs that are used to separate decimal places:

- Depth and diameter of holes: Period
- All other dimensions: Comma

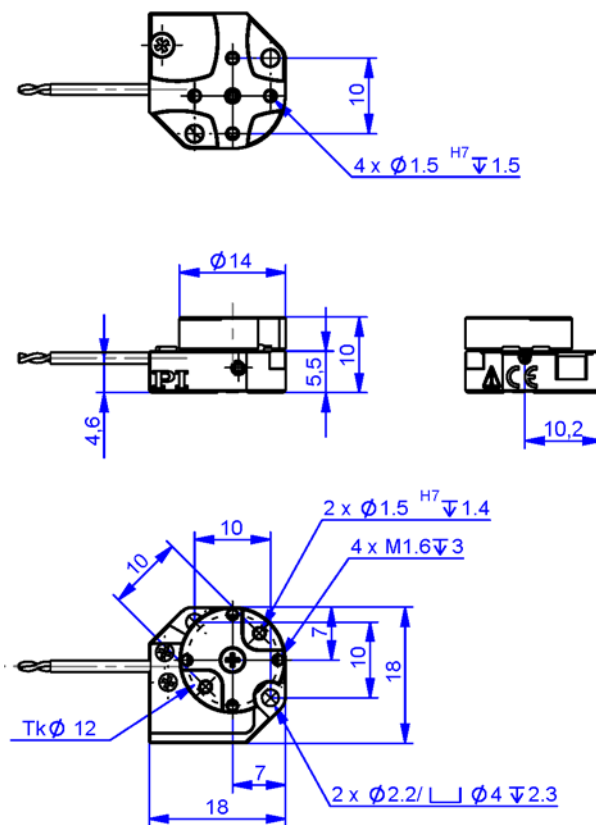

Figure 8: Q-614.900

## 10.4 Pin Assignment

### Connector: Sub-D 15 (m)

The Sub-D 15 (m) connector transmits the signals of the drive.

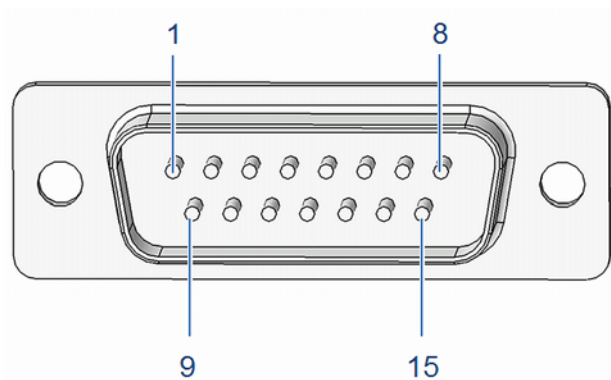

Figure 9: Sub-D 15 (m) connector

Pin	Signal*	Direction
1	-	-
2	Motor (-)	Input
3	Motor (+)	Input
4 to 15	-	-

\* The "-" sign indicates that the corresponding pin has not been assigned.

The cable shield is connected to the connector shell.



## 11 Old Equipment Disposal

In accordance with the applicable EU law, electrical and electronic equipment may not be disposed of with unsorted municipal wastes in the member states of the EU.

When disposing of your old equipment, observe the international, national and local rules and regulations.

To meet the manufacturer's product responsibility with regard to this product, Physik Instrumente (PI) GmbH & Co. KG ensures environmentally correct disposal of old PI equipment that was first put into circulation after 13 August 2005, free of charge.

If you have old PI equipment, you can send it postage-free to the following address:

Physik Instrumente (PI) GmbH & Co. KG  
Auf der Römerstr. 1  
D-76228 Karlsruhe, Germany





## 12 EC Declaration of Conformity

For the Q-614, an EC Declaration of Conformity has been issued in accordance with the following European directives:

2006/95/EC, Low Voltage Directive

2004/108/EC, EMC Directive

2011/65/EU, RoHS Directive

The applied standards certifying the conformity are listed below.

Safety (Low Voltage Directive): EN 61010-1:2010

EMC: EN 61326-1:2013

RoHS: EN 50581:2012

