

P-810, P-830

Piezo Actuators for Light and Medium Loads

Contents

About this Document	3
Symbols and Typographic Conventions.....	3
Other Applicable Documents	4
Downloading Manuals.....	4
Safety	5
Intended Use	5
Safety Precautions.....	6
Electrical Dangers.....	6
Mechanical Dangers.....	8
Thermal Dangers.....	9
Product Description	10
Model Overview	10
Product View	10
Scope of Delivery.....	11
Suitable Electronics	11
Accessories	12
Unpacking	12
Installation	13
General Notes on Installation.....	13
Connecting Piezo Actuator to the Protective Earth Conductor	16
Gluing the Piezo Actuator onto a Surface	17
Affixing the Load.....	18
Connecting the Piezo Actuator to the Electronics.....	19
Startup and Operation	20
Discharging the Piezo Actuator	20
Short-Circuiting the Piezo Actuator.....	21
Maintenance	22
Cleaning the Piezo Actuator	22

User Manual

P810T0004, valid for P-810, P-830

KSch, 10/16/2019



Customer Service	22
<hr/>	
Technical Data	23
<hr/>	
Specifications.....	23
Maximum Ratings.....	23
Ambient Conditions and Classifications	24
Dimensions	25
Assignment of Signals to Stranded Wires.....	26
<hr/>	
Old Equipment Disposal	27
<hr/>	
EU Declaration of Conformity	27
<hr/>	

About this Document

This user manual contains information necessary for the intended use of the P-810 and P-830 piezo actuators.

It assumes that the reader has a fundamental understanding of basic servo systems as well as motion control concepts and applicable safety procedures.

Symbols and Typographic Conventions

The following symbols and typographic conventions are used in this user manual:

CAUTION



Dangerous situation

If not avoided, the dangerous situation will result in minor injury.



- Actions to take to avoid the situation.

NOTICE



Dangerous situation

If not avoided, the dangerous situation will result in damage to the equipment.

- Actions to take to avoid the situation.

INFORMATION

Information for easier handling, tricks, tips, etc.

The following symbols and markings are used in this user manual:

Symbol/Label	Meaning
1.	Action consisting of several steps whose sequential order must be observed
2.	
➤	Action consisting of one or several steps whose sequential order is irrelevant
▪	List item
p. 5	Cross-reference to page 5
	Auf dem Produkt angebrachte Warnzeichen, die auf ausführliche Informationen in diesem Dokument verweisen

Other Applicable Documents

The devices that are mentioned in this user manual are described in their own manuals.

Product number	Description
E-503.00 piezo amplifier module	PZ62E user manual
E-505.00 piezo amplifier module	
E-610.00 piezo amplifier, OEM module	PZ70E user manual
E-617 high-power-piezo amplifier	PZ201E user manual
E-621.CR piezo amplifier/servo controller module	PZ160E user manual
E-621.SR piezo amplifier/servo controller module	PZ115E user manual
E-625.CR piezo amplifier/servo controller	PZ166E user manual
E-625.SR piezo amplifier/servo controller	PZ167E user manual
E-663.00 piezo amplifier, bench-top device	PZ69E user manual
E-709.CR digital piezo controller, OEM module	PZ222E user manual
E-709.CRG digital piezo controller	
E-709.PR digital piezo controller, OEM module	
E-709.PRG digital piezo controller	
E-709.SR digital piezo controller, OEM module	
E-709.SRG digital piezo controller	
E-709.CHG digital piezo controller	
E-831.03 piezo amplifier, OEM module	PZ191E user manual

Downloading Manuals

INFORMATION

If a manual is missing or problems occur with downloading:

- Contact our customer service department (p. 22).

INFORMATION

For products that are supplied with software (CD in the scope of delivery), access to the manuals is protected by a password. Protected manuals are only displayed on the website after entering the password.

The password is included on the CD of the product.

For products with CD: Identify the password

1. Insert the product CD into the PC drive.
2. Switch to the Manuals directory on the CD.
3. In the Manuals directory, open the Release News (file including *releasenews* in the file name).
4. Find the user name and the password in the section "User login for software download" in the Release News.

Downloading manuals

1. Open the website **www.pi.ws**.
2. If access to the manuals is protected by a password:
 - a) Click **Login**.
 - b) Log in with the user name and password.
3. Click **Search**.
4. Enter the product number up to the period (e.g., P-882) or the product family (e.g., PICMA® Bender) into the search field.
5. Click **Start search** or press the key.
6. Open the corresponding product detail page in the list of search results:
 - a) If necessary: Scroll down the list.
 - b) If necessary: Click **Load more results** at the end of the list.
 - c) Click the corresponding product in the list.
7. Scroll down to the **Downloads** section on the product detail page.

The manuals are displayed under **Documentation**.

8. Click the desired manual and save it to the hard disk of your PC or to a data storage medium.

Safety

Intended Use

The P-810 and P-830 piezo actuators (hereinafter referred to as "P-810 / P-830") are intended for indoor use and use in an environment that is free of dirt, oil and lubricants.

The intended use of the piezo actuators is only possible when completely mounted and connected and only in conjunction with suitable electronics (p. 11) that provide the required operating voltages.

The P-810 and P-830 piezo actuators are designed to be integrated into systems that meet the EN 61010-1 safety standard and the EN 61326-1 EMC standard. The operator is responsible for electrical safety and electromagnetic compatibility when integrating these piezo actuators into the overall system.

The piezo actuators may only be started up, operated, maintained and cleaned by authorized and qualified staff.

Safety Precautions

Electrical Dangers

CAUTION



Dangerous voltage and residual charge on piezo actuators!

Temperature changes and compressive stresses can induce charges in the piezo ceramics of the piezo actuator. After being disconnected from the electronics, the piezo actuator can stay charged for several hours. Touching or short-circuiting the stranded wires of the P-810 / P-830 can lead to minor injuries from electric shock. In addition, the piezo actuator can be destroyed by an abrupt contraction.

- Do **not** touch the stranded wires of the P-810 / P-830.
- Do **not** open the P-810 / P-830.
- Discharge (p. 20) the P-810 / P-830 before installation.
- Do not disconnect the P-810 / P-830 from the electronics during operation.

CAUTION



Risk of electric shock if the protective earth conductor is not connected!

If the protective earth conductor is not or not properly connected, dangerous touch voltages can occur on the piezo actuator in the event of malfunction or failure of the system. If touch voltages exist, touching the P-810 / P-830 can result in minor injury from electric shock.

- Connect the P-810 / P-830 to a protective earth conductor (p. 16) before startup.
- Do **not** remove the protective earth conductor during operation.
- If the protective earth conductor has to be removed temporarily (e.g., in the case of modifications), reconnect the P-810 / P-830 to the protective earth conductor before starting it up again.

NOTICE



Reduced lifetime of the piezo actuator due to permanently high voltage!

The permanent application of a high static voltage to piezo actuators leads to a considerable reduction in the lifetime of the piezo ceramics of the piezo actuator.

- When the P-810 / P-830 is not used but the electronics remain switched on to ensure temperature stability, discharge the piezo actuators (p. 20).

NOTICE



Operating voltages that are too high or incorrectly connected!

Operating voltages that are too high or incorrectly connected can cause damage to the P-810 / P-830.

- Do **not** exceed the operating voltage range (p. 23) for which the piezo actuators are specified.
- Only operate the piezo actuators when the operating voltage is properly connected; see "Assignment of Signals to Stranded Wires" (p. 26).

NOTICE



Destruction of the piezo actuator by electric flashovers!

The use of the P-810 / P-830 in environments that increase the electrical conductivity can lead to the destruction of the piezo actuators by electric flashovers. Electric flashovers can be caused by moisture, high humidity, liquids and conductive materials such as metal dust. In addition, electric flashovers can also occur in certain air pressure ranges due to the increased conductivity of the air.

- Avoid operating the P-810 / P-830 in environments that can increase the electric conductivity.
- Only operate the piezo actuators within the permissible ambient conditions and classifications (p. 24).

NOTICE



Damage after reconnecting due to a charged piezo actuator!

The P-810 / P-830 can remain charged if it is disconnected from the electronics during operation. Reconnecting a charged piezo actuator to electronics during operation can cause a mechanical impulse that will damage the piezo actuator.

- Do **not** pull the connecting cable of the piezo actuator out of the electronics during operation.

If the connecting cable of the piezo actuator is accidentally pulled out of the electronics during operation:

- Discharge the piezo actuator (p. 20).
- Switch off the electronics before you reconnect the piezo actuator.

NOTICE



Damage due to unsuitable cables!

Unsuitable cables can damage the electronics.

- Only use cables from PI for connecting the P-810 / P-830 to the electronics.

Mechanical Dangers

NOTICE



Destruction of the piezo actuators by loads that are too high!

Loads that are too high can destroy the P-810 / P-830.

- Do **not** exceed the maximum push / pull force capacity according to the specifications (p. 23).

NOTICE



Destruction of the piezo actuators by mechanical overload!

Torques, bending forces, shearing forces and lateral forces can destroy the P-810 / P-830.

- Avoid bending forces and lateral forces on the movable tip of the P-810 / P-830.
- **Avoid any torque on the base and the movable tip of the P-810 / P-830.**
- Make sure that the center of load of the moving system is on the motion axis of the piezo actuator.
- Avoid an uneven load distribution by using suitable structures or guide elements (e.g., spherical tips or flexures).
- Observe the information on parallelism in the "Dimensions" section (p. 25).

NOTICE



Destruction of the piezo actuators by dynamic forces!

Dynamic operation without a preload can destroy the P-810 / P-830. If a preload is applied to the P-810 / P-830 within a mechanical system, the forces that occur during dynamic operation can cancel the preload and destroy the P-810 / P-830.

- Do **not** exceed the maximum push / pull force capacity according to the specifications (p. 23).

NOTICE



Destruction of the piezo actuators by operating frequencies that are too high!

An operating frequency that is too high can destroy the P-810 / P-830.

- Select the operating frequency so that the following conditions are met:
 - The operating frequency is maximally one third of the resonant frequency (resonant frequency of the unloaded piezo actuator see "Specifications", p. 23). When the piezo actuator is loaded, the operating frequency must be reduced according to your application. Details can be found online:
<http://www.piceramic.com/piezo-technology/properties-piezo-actuators/dynamic-operation.html>
 - The dynamic forces that occur during operation do **not** exceed the maximum push / pull force capacity according to the specifications (p. 23).

NOTICE



Uncontrolled oscillation!

Oscillations can cause irreparable damage to the P-810 / P-830. Oscillation is indicated by a humming and can result from operation of a piezo actuator near its resonant frequency.

- If you notice oscillation, immediately stop the piezo actuator.

Thermal Dangers

CAUTION



Burning from hot surface!

The surface of the P-810 / P-830 piezo actuator can heat up during operation. Touching the piezo actuators can result in minor injuries from burning.

- Cool the piezo actuator so that the temperature of its surface and surrounding parts does **not** exceed 65 °C.
- If sufficient cooling is not possible: Make sure that the hot piezo actuator **cannot** be touched.
- If sufficient cooling and protection against contact are not possible: Mark the danger zone in accordance with the legal regulations.

NOTICE



Heating up of the P-810 / P-830 during operation!

The heat produced during operation of the piezo actuator can affect your application.

- Install the piezo actuator so that your application is not affected by the dissipating heat.

NOTICE



Destruction of the piezo actuator by overheating!

Overheating can destroy the piezo actuator.

- Adjust the operating voltage, operating frequency and/or operating time so that the maximum operating temperature of the piezo actuator is not exceeded; see "Ambient Conditions and Classifications" (p. 24) and "Maximum Ratings" (p. 23).

Product Description

Model Overview

Model	Description
P-810.10	Piezo actuator, 15 μm travel range, 50 / 1 N
P-810.20	Piezo actuator, 30 μm travel range, 50 / 1 N
P-810.30	Piezo actuator, 45 μm travel range, 50 / 1 N
P-830.10	Piezo actuator, 15 μm travel range, 1000 / 5 N
P-830.20	Piezo actuator, 30 μm travel range, 1000 / 5 N
P-830.30	Piezo actuator, 45 μm travel range, 1000 / 5 N
P-830.40	Piezo actuator, 60 μm travel range, 1000 / 5 N

Product View

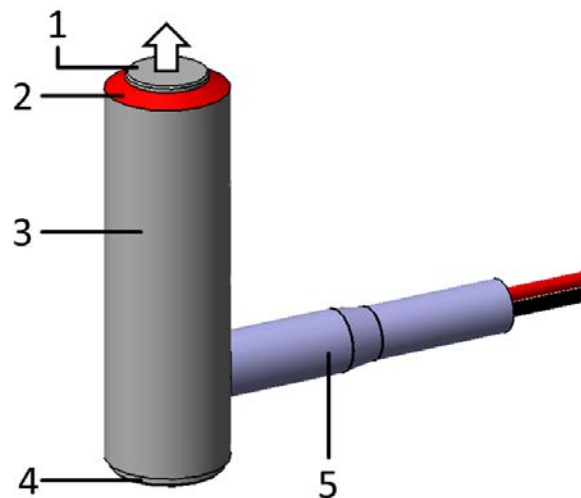

Figure 1: Product view of P-810.10 as example

- 1: Movable tip
 - 2: Silicone ring (red)
 - 3: Housing made of stainless steel
 - 4: Base
 - 5: Cable exit with shrink tubing and two stranded wires insulated with PTFE
- Arrow: Positive direction of motion

Scope of Delivery

Product number	Description
P-810 or P-830	PICMA® actuator
3852	Shorting clamp
PZ264EK	Short instructions for PICMA® multilayer piezo actuators

Suitable Electronics

Product number	Description
E-503.00	Piezo amplifier module, -30 to 130 V, 3 channels
E-505.00	Piezo amplifier module, 2 A, -30 to 130 V, 1 channel
E-610.00	Piezo amplifier, -30 to 130 V, OEM module, 1 channel
E-617	High-power-piezo amplifier with energy recovery, -30 to 130 V, 100 W, 1 channel
E-621.CR	Piezo amplifier/servo controller module, -30 to 130 V, 1 channel, capacitive sensor, USB, RS-232
E-621.SR	Piezo amplifier/servo controller module, -30 to 130 V, 1 channel, SGS sensor, USB, RS-232
E-625.CR	Piezo amplifier/servo controller, -30 to 130 V, 1 channel, capacitive sensor, USB, RS-232
E-625.SR	Piezo amplifier/servo controller, -30 to 130 V, 1 channel, SGS sensor, USB, RS-232
E-663.00	Piezo amplifier, -20 to 120 V, bench-top device, 3 channels
E-709.CR	Digital piezo controller, OEM module, -30 to 130 V, 1 channel, capacitive sensor
E-709.CRG	Digital piezo controller, -30 to 130 V, 1 channel, capacitive sensor, bench-top device
E-709.PR	Digital piezo controller, OEM module, -30 to 130 V, 1 channel, piezoresistive sensor
E-709.PRG	Digital piezo controller, -30 to 130 V, 1 channel, piezoresistive, bench-top device
E-709.SR	Digital piezo controller, OEM module, -30 to 130 V, 1 channel, SGS sensor
E-709.SRG	Digital piezo controller, -30 to 130 V, 1 channel, SGS, bench-top device
E-709.CHG	Digital piezo controller, -30 to 130 V, 1 channel, high output power, capacitive sensor, bench-top device
E-831.03	Piezo amplifier, OEM module, up to -30 to 130 V, 1 channel

➤ To order, contact our customer service department (p. 22).

Accessories

Product number	Description
	The P-890.xx cable is for connecting the P-810 or P-830 to a low-voltage piezo amplifier with a single-pole LEMO socket. The cable is soldered on the actuator side. Connector: FFS.00.250.CTCE24 Cable: RG 178 (Teflon)
P-890.10	Cable for piezo voltage, LEMO connector/open end, 1 m
P-890.20	Cable for piezo voltage, LEMO connector/open end, 5 m
	If a LEMO connector FFA.00.250 is soldered on the actuator side, the P-891.xx cable can be used as extension cable.
P-891.01	Extension cable for piezo voltage, LEMO connectors, 1 m
P-891.02	Extension cable for piezo voltage, LEMO connectors, 2 m
P-891.03	Extension cable for piezo voltage, LEMO connectors, 3 m
P-891.05	Extension cable for piezo voltage, LEMO connectors, 5 m
P-891.10	Extension cable for piezo voltage, LEMO connectors, 10 m

- To order, contact our customer service department (p. 22).

Unpacking

NOTICE



Mechanical overload due to incorrect handling!

An impermissible mechanical load on the movable tip of the P-810 / P-830 can cause damage to the piezo actuator and lead to loss in accuracy.

- Only hold the P-810 / P-830 by the housing.

1. Unpack the piezo actuator with care.
2. Compare the contents with the items listed in the contract and the packing list.
3. Inspect the contents for signs of damage. If parts are missing or you notice signs of damage, contact PI immediately.
4. Keep all packaging materials in case the product needs to be returned.

Installation

General Notes on Installation

Piezo actuators may only be loaded axially. The following figures show sketches of the P-810 / P-830 piezo actuator with possible design solutions. The figures help to prevent mounting errors.



Figure 2: Sketch of separate P-810 / P-830 piezo actuator

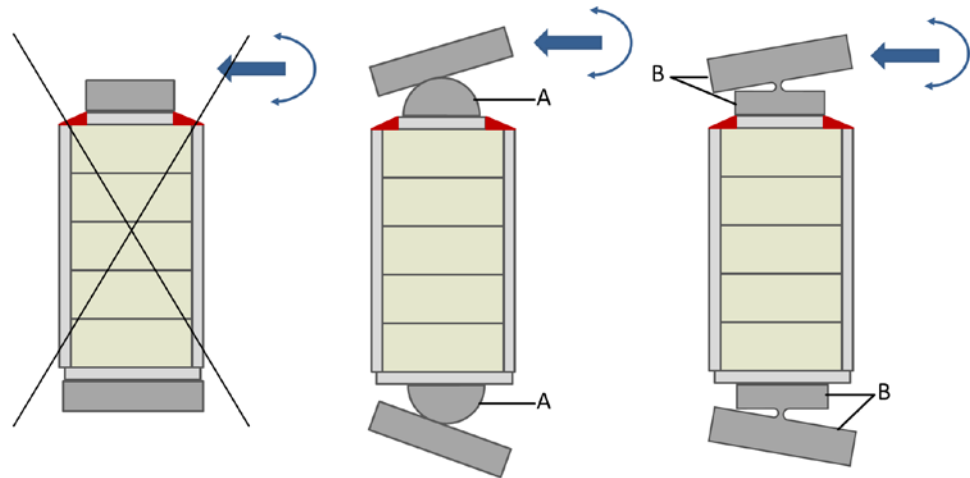

Figure 3: Prevention of lateral forces and torque (A: spherical tip, B: flexure, not included in delivery)

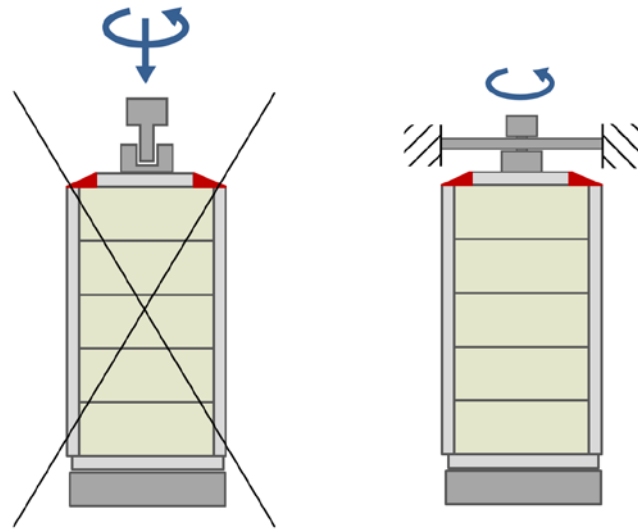

Figure 4: Prevention of torque

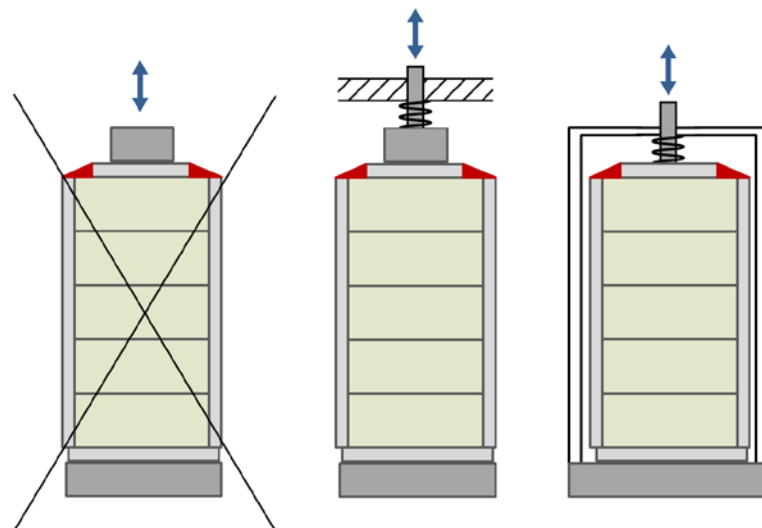

Figure 5: Prevention of tensile stress by means of a mechanical preload

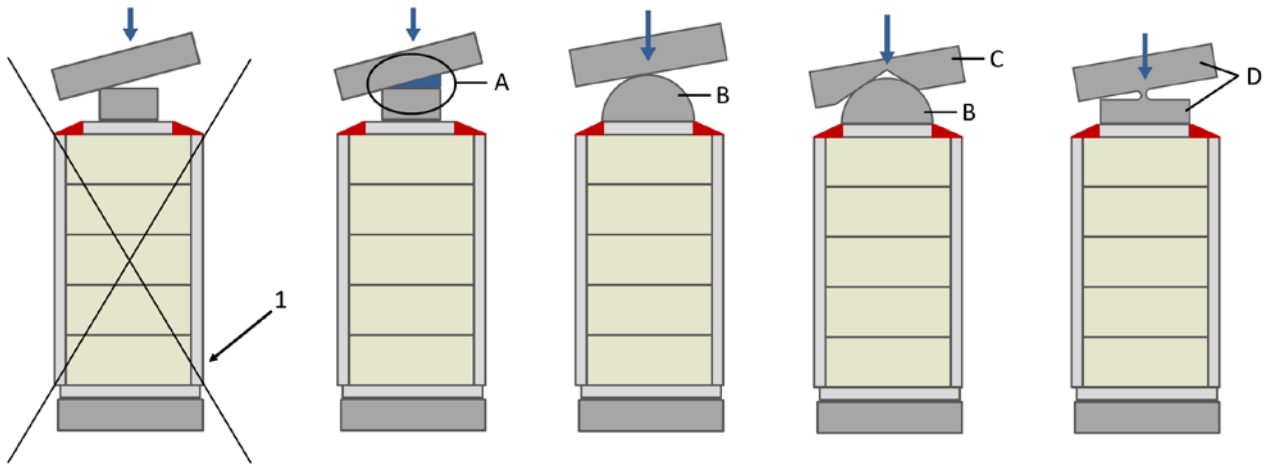

Figure 6: Prevention of an irregular load application (1: Tensile stress)

- A: Full-surface gluing
- B: Spherical tip
- C: Calotte
- D: Flexure

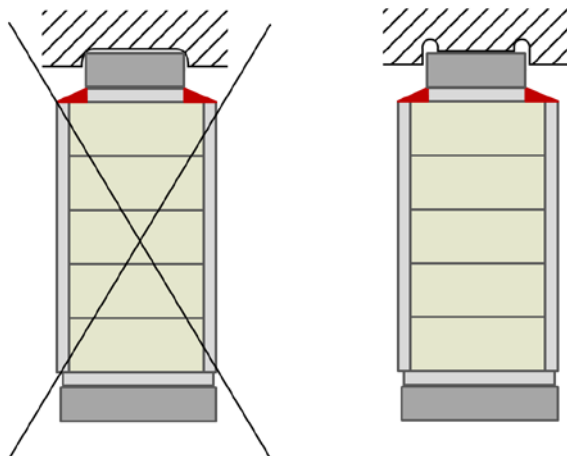

Figure 7: Full-area contact of the piezo actuator

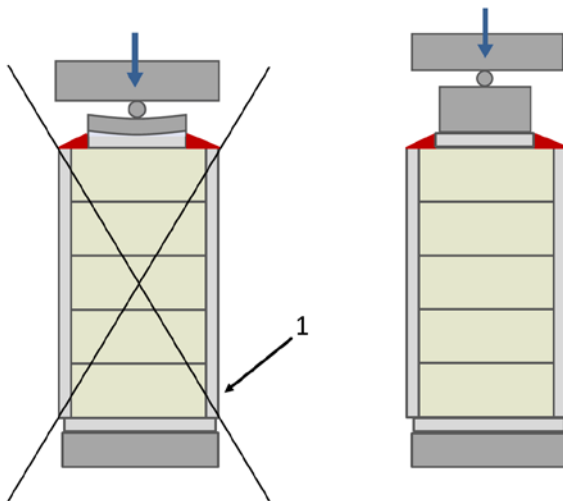

Figure 8: Proper dimensioning of the end pieces in the case of point contact (1: Tensile stress)

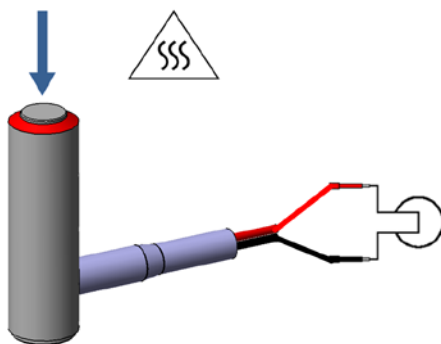

Figure 9: Mechanical or thermal loads electrically charge the piezo actuator. Mount only when short-circuited.

Connecting Piezo Actuator to the Protective Earth Conductor

INFORMATION

Observe the applicable standards for mounting the protective earth conductor.

Since the P-810 / P-830 has no separate protective earth connection, it must be grounded by gluing it onto a surface which is connected to the protective earth conductor.

Connecting the piezo actuator to the protective earth conductor

- See “Gluing the Piezo Actuator onto a Surface” (p. 17) for instructions.

Gluing the Piezo Actuator onto a Surface

The P-810 and P-830 piezo actuators are glued onto metal or ceramic surfaces.

Requirements

- ✓ You have read and understood the safety precautions (p. 6).
- ✓ You have read and understood the general notes on installation (p. 13).
- ✓ The piezo actuator is discharged (p. 20) and short-circuited (p. 21).
- ✓ The piezo actuator is **not** connected to the electronics.
- ✓ You have read and understood the user information of the manufacturer of the adhesive.
- ✓ You have provided a suitable surface:
 - The flatness of the surface is $\leq 10 \mu\text{m}$.
 - The surface is electrically conductive.
 - The surface is connected to a suitable protective earth conductor: Cross-sectional area of the cable $\geq 0.75 \text{ mm}^2$.
 - The surface is dry, dust-free, and grease-free.
 - For applications with large temperature changes: The surface has the same thermal expansion properties as the base of the P-810 / P-830 (i.e., $10.3 \times 10^{-6} \text{ K}^{-1}$.)
- ✓ You have accounted for the space required to route cables without bending and according to regulations.

Tools and accessories

- Electrically conductive adhesive (e.g., cold-hardening epoxy resin adhesive)

Gluing the piezo actuator onto a surface

1. Glue the piezo actuator onto the surface:
 - Apply the thinnest possible layer of adhesive.
 - During the hardening process, maintain the operating temperature range (p. 24) specified for the piezo actuator.
 - Observe the temperature expansion coefficients of the materials involved.
2. Press the piezo actuator until the adhesive has hardened.
3. Make sure that the contact resistance is $< 0.1 \Omega$ at 25 A at all connection points relevant for mounting the protective earth conductor.
4. Check that the piezo actuator is affixed firmly to the surface.

Affixing the Load

The P-810 and P-830 piezo actuators can be coupled to a load in various ways, depending on the application:

- Gluing the piezo actuator (p. 16) into the mechanical system to be moved or into a flexure
- Using a spherical tip:
 - Gluing a hardened spherical tip, which establishes a single-point contact to an even surface
 - Gluing a hardened spherical tip, which establishes a ring-shaped contact to a calotte

INFORMATION

Diagrams showing how to couple the P-810 and P-830 piezo actuators to a load can be found in "General Notes on Installation" (p. 13).

Requirements

- ✓ You have read and understood the safety precautions (p. 6).
- ✓ You have read and understood the general notes on installation (p. 13).
- ✓ The piezo actuator is discharged (p. 20) and short-circuited (p. 21).
- ✓ The piezo actuator is **not** connected to the electronics.
- ✓ You have read and understood the user information of the manufacturer of the adhesive.

Tools and accessories

- Electrically conductive adhesive (e.g., cold-hardening epoxy resin adhesive)
- When using a spherical tip: Suitable spherical tip
- When using a flexure: Suitable flexure

Applying the load

- ✓ Apply the load evenly.

If the piezo actuator is coupled in a milling pocket:

- Ensure that there is full-area contact at the movable tip of the piezo actuator. For this purpose, choose the dimensions of the milling pocket correspondingly or make free cuts in the milling pocket.

If a point load is applied to the end piece of the piezo actuator:

- Dimension the end piece so that its thickness corresponds to half the cross-sectional dimension in order to prevent tensile stress on the piezo actuator.

Connecting the Piezo Actuator to the Electronics

The P-810 / P-830 is connected to a LEMO socket, a terminal, or soldering pins, depending on the electronics.

This section describes how the P-810 / P-830 is connected with the P-890.xx coaxial cable to electronics with a single-pole LEMO socket.

- If you use a self-made connecting cable instead of the P-890.xx coaxial cable for connection to a single-pole LEMO socket, observe the relevant standards as well as the assembly information of the manufacturer of the connector used.
- For connection to the electronics with a two-pole LEMO socket, contact our customer service department (p. 22).
- For connection to terminals or solder pins, see the manual of the respective electronics used (p. 4).

INFORMATION

The P-810 / P-830 has color-coded stranded wires:

- Red stranded wire: Voltage connection (+)
- Black stranded wire: Ground (-)

Requirements

- ✓ You have read and understood the safety precautions (p. 6).
- ✓ You have installed (p.13) the P-810 / P-830 correctly.
- ✓ You have read and understood the user manual of the electronics used.
- ✓ If the piezo actuator is not short-circuited: The piezo actuator is discharged (p. 20).
- ✓ The electronics are **switched off**.
- ✓ The electronics have a single-pole LEMO socket.

Tools and accessories

- P-890.xx coaxial cable (p. 12), LEMO single-pole to open end (can be ordered separately)
- Suitable soldering iron
- Suitable solder
- Suitable cable tools

Connecting the piezo actuator to the electronics

1. If necessary, shorten the wire and the cable shield of the coaxial cable to the correct length.
2. Make the stranded wires of the piezo actuator accessible:
 - If the stranded wires of the piezo actuator are short-circuited, sever the connection between the stranded wires.

- Remove all aids and components that have been connected to the piezo actuator for short-circuiting or discharging (e.g., shorting clamp or discharging resistor).
- 3. Solder the red stranded wire of the piezo actuator to the wire of the coaxial cable that is connected to the inner contact of the LEMO connector.
- 4. Solder the black stranded wire of the piezo actuator to the cable shield of the coaxial cable.
- 5. Insulate the soldered cable connections appropriately.
- 6. Connect the connector of the piezo actuator to the corresponding connection on the electronics.

Startup and Operation

INFORMATION

The outwards motion of the movable tip corresponds to the positive direction of motion and is proportional to the applied operating voltage.

Requirements

- ✓ You have read and understood the safety precautions (p. 6).

Startup and operation

- ✓ Follow the instructions in the manual of the electronics used for startup and operation of the P-810 / P-830.

Discharging the Piezo Actuator

The P-810 / P-830 must be discharged in the following cases:

- When the piezo actuator is not in use but the electronics remain switched on to ensure temperature stability
- If the piezo actuator has become accidentally charged due to thermal or mechanical loading
- If the connecting cable of a piezo actuator is accidentally pulled out of the electronics during operation

Requirements

- ✓ You have read and understood the safety precautions (p. 6).

Tools and accessories

If the piezo actuator is not connected to the electronics:

- Only for P-810 or P-830 **without** connector (condition as supplied):
 - 10 k Ω discharge resistor (not included in scope of delivery); touchable parts must be adequately insulated for the operating voltage range (p. 23) of the actuator.
- Only for P-810 or P-830 **with** connector (p. 19):
 - Electronics (p. 11) from PI or suitable shorting plug (available on request)

Discharging a piezo actuator connected to the electronics

- Set the piezo voltage to 0 V on the electronics.

Discharging a piezo actuator not connected to the electronics

If the piezo actuator does **not** have a connector:

1. Ensure adequate protection against touching live parts.
2. Short-circuit the stranded wires of the piezo actuator for at least a few seconds using a **10 k Ω discharge resistor**.

If the piezo actuator has a connector (p. 19):

- Connect the voltage connector of the piezo actuator to the switched off PI electronics, which has an internal discharge resistor, for at least a few seconds.
- Alternative: Connect a suitable shorting plug with integrated discharge resistor to the voltage connector of the piezo actuator for at least a few seconds.

Short-Circuiting the Piezo Actuator

The P-810 / P-830 must be discharged (p. 20) and short-circuited before demounting (e.g., before cleaning and transportation of the piezo actuators) as well as for modifications.

Requirements

- ✓ You have read and understood the safety precautions (p. 6).
- ✓ You have discharged (p. 20) the piezo actuator and disconnected it from the electronics.

Tools and accessories

- Only for P-810 or P-830 **without** connector (condition as supplied):
 - Suitable shorting clamp (p. 11)
- Only for P-810 or P-830 **with** connector (p. 19):
 - Suitable shorting plug (available on request)

Short-circuiting the piezo actuator

If the piezo actuator does **not** have a connector:

- Short-circuit the stranded wires of the **discharged** piezo actuator with a suitable shorting clamp or twist the stranded wires.

If the piezo actuator has a connector (p. 19):

- Connect a suitable shorting plug with integrated discharge resistor to the voltage connector of the piezo actuator.

Maintenance

NOTICE



Damage due to improper maintenance!

The P-810 / P-830 piezo actuator is maintenance-free and precisely aligned.

- Do **not** open the piezo actuators.

Cleaning the Piezo Actuator

Requirements

- ✓ You have discharged (p. 20) the piezo actuator.
- ✓ The piezo actuator is **not** connected to the electronics.

Cleaning the piezo actuator

- Clean the surfaces of the piezo actuator with a cloth that is dampened with a mild cleanser or disinfectant (e.g., ethanol or isopropyl alcohol).
- Do **not** do any ultrasonic cleaning.

Customer Service

For inquiries and orders, contact your PI sales engineer or send us an email (service@pi.de).

- If you have questions concerning your system, have the following information ready:
 - Product and serial numbers of all products in the system
 - Firmware version of the controller (if present)
 - Version of the driver or the software (if present)
 - Operating system on the PC (if present)
- If possible: Take photographs or make videos of your system that can be sent to our customer service department if requested.

The latest versions of the user manuals are available for download (p. 4) on our website.

Technical Data

Specifications

	P-810.10	P-810.20	P-810.30	P-830.10	P-830.20	P-830.30	P-830.40	Unit	Tolerance
Travel range for 0 to 100 V	15	30	45	15	30	45	60	µm	±20 %
Resolution*	0.15	0.3	0.45	0.15	0.3	0.45	0.6	nm	
Static large signal stiffness**	14	7	4	57	27	19	15	N/µm	±20 %
Push- / pull force capacity	50 / 1	50 / 1	50 / 1	1000 / 5	1000 / 5	1000 / 5	1000 / 5	N	
Elektrical capacitance	0.3	0.7	1	1.5	3	4.5	6	µF	±20 %
Resonant frequency f_0 (unloaded)	22	15	12	23	14	10	8.5	kHz	±20 %
Mass	4	6	8	10	16	21	27	g	±5 %
Length L	20	38	56	22	40	58	76	mm	±0.3
Recommended electronics	E-503,E-505, E-610, E-617, E-621, E-625, E-663, E-709, E-831								

* The resolution of piezo actuators is not limited by stiction or friction. Value given is noise equivalent motion with E-503 amplifier.

** Dynamic small-signal stiffness is approximately 30 % higher.

Operating temperature range: -20 to 80 °C



Housing: Nonmagnetic stainless steel, movable tip and base: stainless steel

Recommended preload for dynamic operation: 10 to 20 MPa

All specifications based on room temperature (22 °C ±3 °C).

Maximum Ratings

The P-810 / P-830 is designed for the following maximum ratings:

Model	Maximum operating voltage 	Maximum operating frequency (unloaded) ¹ 	Maximum power consumption ² 
P-810.10	0 to 100 V	7.3 kHz	4.3 W
P-810.20	0 to 100 V	5 kHz	8.6 W
P-810.30	0 to 100 V	4 kHz	12.9 W
P-830.10	0 to 100 V	7.7 kHz	4.3 W
P-830.20	0 to 100 V	4.7 kHz	8.6 W
P-830.30	0 to 100 V	3.3 kHz	12.9 W
P-830.40	0 to 100 V	2.8 kHz	17.W

¹ To ensure stable operation, the maximum operating frequency is defined as approximately 1/3 of the mechanical resonant frequency.

² The heat generated by the piezo actuator during dynamic operation limits the value for maximum power consumption.

Details can be found online:

<http://piceramic.com/piezo-technology/properties-piezo-actuators/electrical-operation.html>

Ambient Conditions and Classifications

The following ambient conditions and classifications must be observed for the P-810 / P-830:

Area of application	For indoor use only
Maximum altitude	2000 m
Air pressure	1100 hPa to 0.1 hPa
Relative humidity	Highest relative humidity 80 % for temperatures up to 31 °C Decreasing linearly to 50 % relative humidity at 40 °C
Operating temperature	-20 °C to 80 °C
Storage temperature	-20 °C to 80 °C
Transport temperature	-20 °C to 80 °C
Overvoltage category	II
Protection class	I

The P-810 / P-830 is intended for installation in devices that fulfil the following classifications:

Degree of pollution	1
Degree of protection according to IEC 60529	IP20

Dimensions

Dimensions in mm. Note that the decimal places are separated by a comma in the drawings.

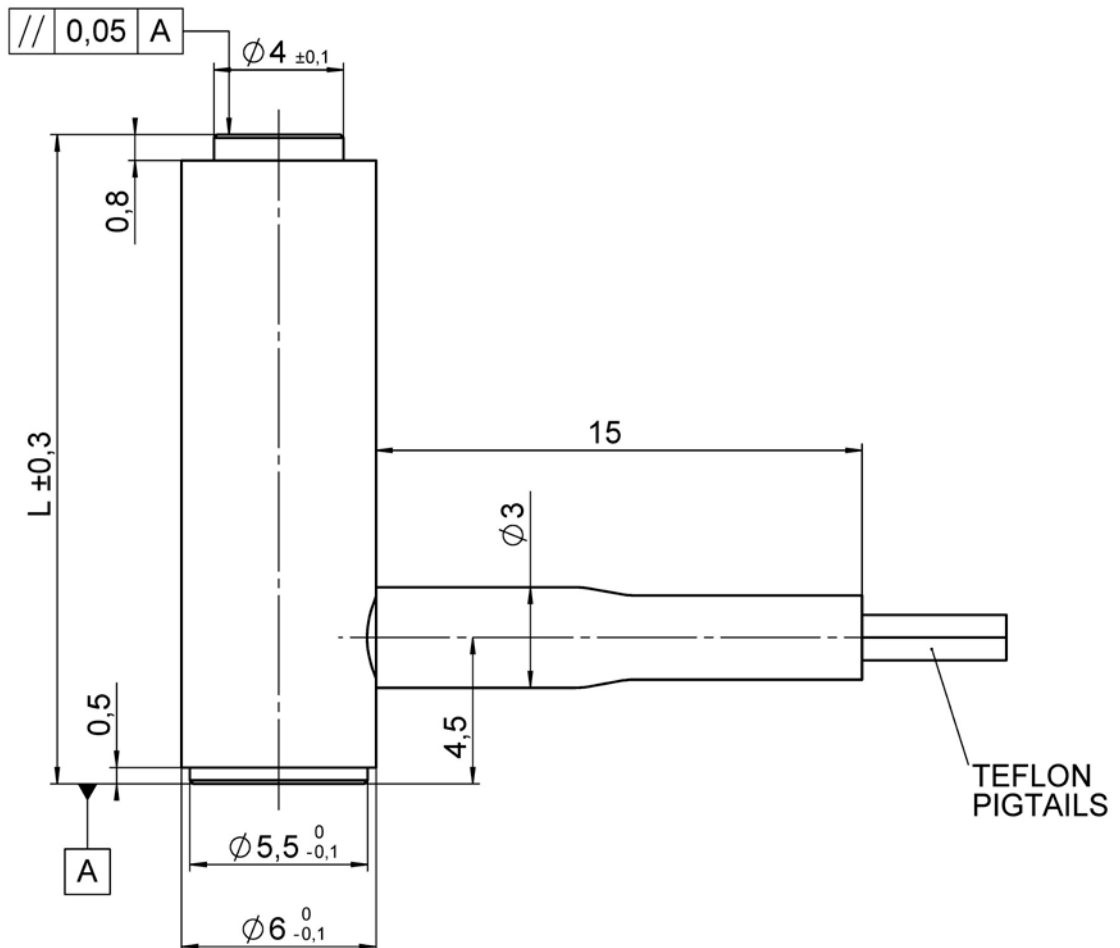

P-810.10	15 μ m	L=20
P-810.20	30 μ m	L=38
P-810.30	45 μ m	L=56

Figure 10: Dimensions of the P-810

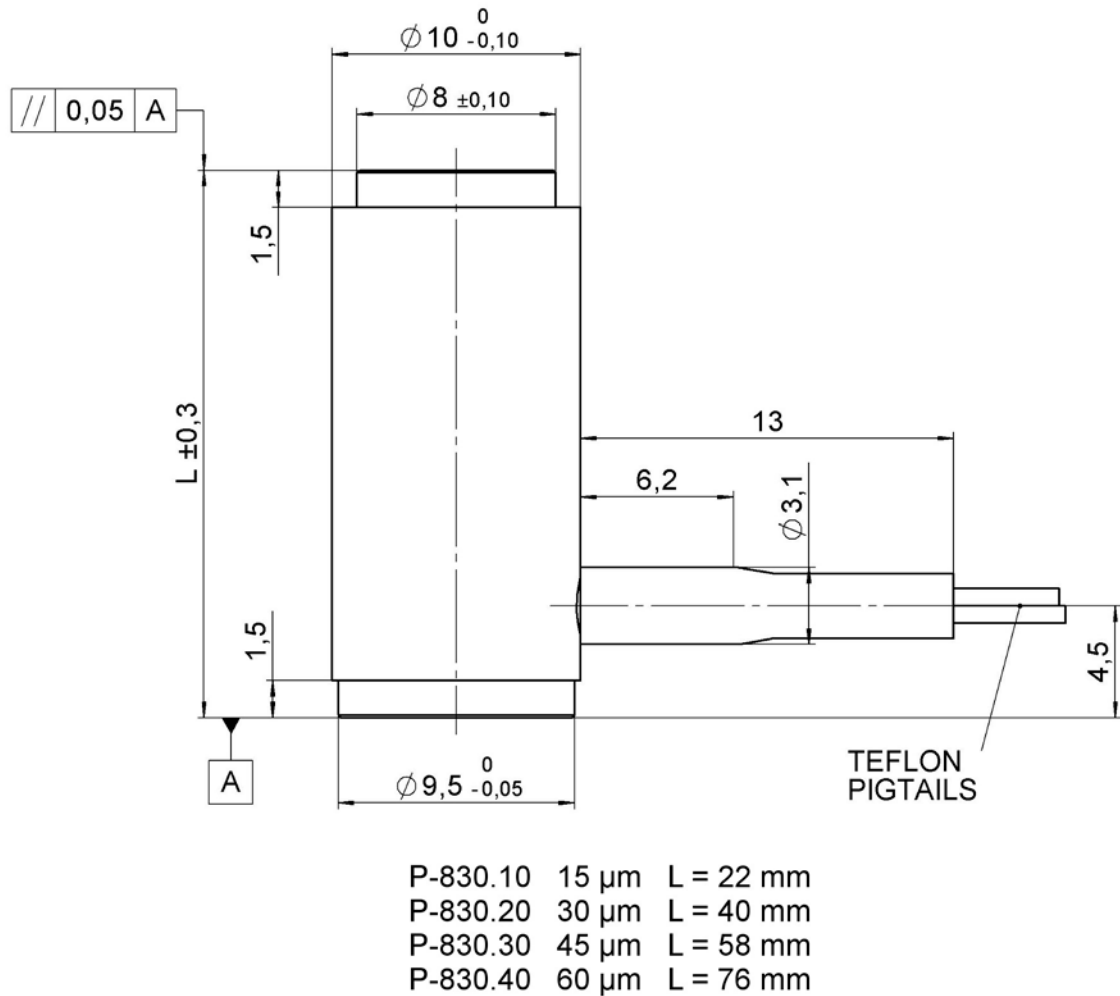

Figure 11: Dimensions of the P-830

Assignment of Signals to Stranded Wires

Signal	Color of stranded wire	Labeling
PZT (+)	Red	+
GND	Black	-

Old Equipment Disposal

In accordance with EU law, electrical and electronic equipment may not be disposed of in EU member states via the municipal residual waste.

Dispose of your old equipment according to international, national, and local rules and regulations.

In order to fulfil its responsibility as the product manufacturer, Physik Instrumente (PI) GmbH & Co. KG undertakes environmentally correct disposal of all old PI equipment made available on the market after 13 August 2005 without charge.

Any old PI equipment can be sent free of charge to the following address:

Physik Instrumente (PI) GmbH & Co. KG
Auf der Roemerstr. 1
D-76228 Karlsruhe, Germany



EU Declaration of Conformity

An EU Declaration of Conformity was issued for the P-810 / P-830 in accordance with the following European directives:

RoHS Directive

The applied standards certifying the conformity are listed below.

RoHS: EN 50581